

TL-EX-FH-0101 Y1/ (M)-Series Explosion-proof Button / Switch (Board Back Type)

1 Application and Features

- Explosion protection ATEX
- Application in hazardous are Zone 1 and Zone 2, Zone 21 and Zone 22
- Electrical accessories head types: two-position, three-position, three-position left and right self-resetting, three-position right self-resetting.
- There are two types of installation method: rail mounted type and board back type.
- Rail mounted type: contact is installed on rail.
- Board back type: contact is installed behind the cover, quick disassembly structure, easy installation and maintenance.









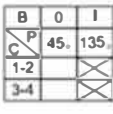
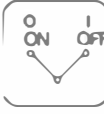
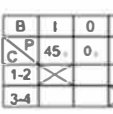
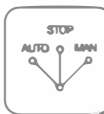
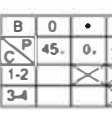

2 Nomenclature

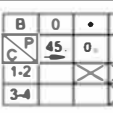

TL-EX-FH-0101 - □ □

- None-Rail mounted type
- M-Board back type (Optional)

Switch code	Contact chart	Knob position	Switch code	Contact chart	Knob position	Switch code	Contact chart	Knob position
01			03			05		
02			04			06		

Explosion-proof button / switch

• Electrical accessories (Optional)

TL-EX-FH-0101 - □ / □ □ □

- F-Label holder (Optional)
- Position (Pull out the key)
 - 0- Middle
 - L-Left
 - R-Right

Identification code	01	02	03	04	05	11	12	13	14	15	16	99
Identification words	0-I	I - II	I-0-II	0--I	0--I	ON OFF	AUTO MAN	LOCAL REMOTE	AUTO STOP MAN	STOP RUN START	LOCK RUN START	Upon request
Color of Identification board	Silver	Silver	Silver	Silver	Silver	Silver	Silver	Silver	Silver	Silver	Silver	Silver
Color of words	Black	Black	Black	Black	Black	Black	Black	Black	Black	Black	Black	Black

Y1- Key-operated button head

Explosion-proof key-operated button head

Note: A yellow ring will be equipped when without label holder.

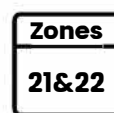
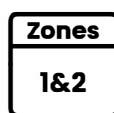

TL-EX-FH-0101 Y1/ (M)-Series Explosion-proof Button / Switch (Board Back Type)

3 Technical Parameter

Ex marking	Gas	Ex II 2 G Ex db eb IIC Gb	Ex db eb IIC Gb	
Ex marking of electrical accessories	Gas	Ex II 2 G Ex eb IIC Gb	Ex eb IIC Gb	
	Dust	Ex II 2 D Ex tb IIIC Db	Ex tb IIIC Db	
Conformity to standards		IEC 60079-0, IEC 60079-1, IEC 60079-7, IEC 60079-31 EN 60079-0, EN60079-1, EN60079-7, EN60079-31		
Pole		Rail mounted type:1(2), Board back type:2		
Degree of protection		Terminal IP20, IP66 (After assembly with electrical accessories)		
Material	Button enclosure	Nylon (PA66), Polycarbonate (PC)		
	Electrical accessories	Nylon (PA66), Polycarbonate (PC)		
Parameter	Rated voltage	220V~250V AC	380V~415V AC	220V DC
	Rated current	6A, 10A	6A, 10A	0.25A
	Rated voltage	110V DC	60V DC	24V DC
	Rated current	1.6A	0.9A	0.4A
Ambient temperature	Rail mounted type	6A: -40°C ~ +70°C, 10A: -40°C ~ +60°C		
	Board back type	6A: -40°C ~ +70°C, 10A: -40°C ~ +65°C		
Component weight		Rail mounted type: 30g × 3 Board back type: 80g		
Terminal wire diameter		6A: 0.75 ~ 2.5mm ² , 10A: 1.5 ~ 2.5mm ²		
Function	Electrical accessories	Function	Weight	
	∅ 38 Operating handle (S1)	Two-position: Rotate within 90°	36g	
	∅ 65 Operating handle (S2)	Three-position: Rotate within 90°, three-position positioning Three-position left and right self-resetting, three-position right self-resetting	50g	
	Square operating handle (S3)	∅ 65 Operating handle can be with padlock upon request.	50g	

4 Outline Dimension of Electrical Accessories

• Rail mounted (Board back) type

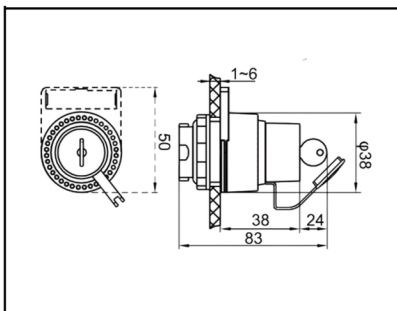

5 Component Outline Dimension (Dimensions in mm)

• Rail mounted type

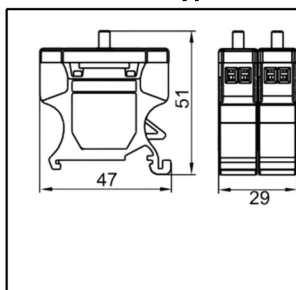

• Board back type

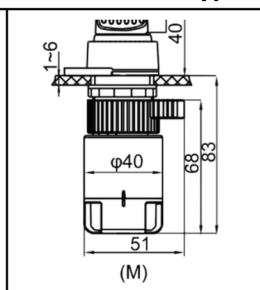

6 Installation Distance (Dimensions in mm)

• Rail mounted type

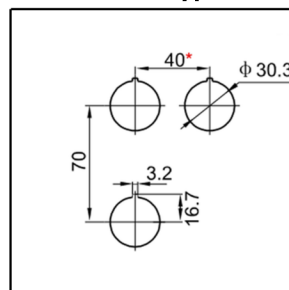

• Board back type

