

**TECHLED**

Techled Elektronik San. Tic. A.Ş.



# Explosion Proof Control and Installation Equipment Catalogue



Visit our  
website!

## Durable. Reliable.

TechLED brings safety into control systems, cable entries, and power connections. Every product in our installation and control range is ATEX certified and engineered for consistent performance in the most demanding industrial environments.

From Ex push-button stations, indicator lights, sockets and plugs, to Ex junction boxes and cable glands, TechLED safeguards the essential points where decisions are made, power flows, and systems connect.

With field-proven reliability, modular engineering, and practical design, TechLED ensures complete compatibility, whether in new installations or retrofit upgrades

TechLED doesn't just illuminate the site. TechLED commands, connects, and protects it.

## Why TechLED?

- TechLED explosion proof control, connection, and cable entry products are designed and certified to meet ATEX standards, enabling safe and uninterrupted operation in explosive atmospheres.
- IP66/67 protection, corrosion-resistant hardware, and chemical-resistant enclosures ensure long-term durability in extreme industrial conditions.
- Modular and operator friendly designs provide fast installation, easy maintenance, and reduce the risk of human error
- A wide product range and multiple configurations allow tailored solutions for every project. From single push-button boxes to multi-entry signal units and compact or armored cable glands, TechLED has what is needed.

# Contents

TL-EX-FH-BSP01 Series Plug&Socket	01
TL-EX-FH-BSP03 Series Plug&Socket	05
TL-EX-FH-BSP07 Series Plug&Socket	07
TL-EX-FH-DP03 Series Control Box&Distribution Box	11
TL-EX-FH-DP05 Series Control Box&Distribution Box	14
TL-EX-FH-DP06 Series Control Box&Distribution Box	16
TL-EX-FH-DP07 Series Control Box&Distribution Box	20
TL-EX-FH-DP11 Series Enclosure	23
TL-EX-FH-E03 Series Enclosure	27
TL-EX-FH-DP23 Series Control Box&Distribution Box	30
TL-EX-FH-DP32 Series Control Box&Distribution Box	37
TL-EX-FH-DP50 Series Control Box&Distribution Box	42
TL-EX-FH-BH02 Series Stainless Terminal Box	46
TL-EX-FH-BH03 Series Plastic Terminal Box	49
TL-EX-FH-BH05 Series Plastic Terminal Box	51
TL-EX-FH-BX02 Series Stainless Terminal Box	53
TL-EX-FH-BX03 Series Plastic Terminal Box	57
TL-EX-FH-BX05 Series Plastic Terminal Box	61
TL-EX-FH-0101M Series Board Back Type/Butoon/Switch/Signal Lamp Modul	64
TL-EX-FH-0101A(M) Series Board Back Type/Butoon/Switch/Signal Lamp Modul	66
TL-EX-FH-0101 S1/M Series Board Back Type/Butoon/Switch/Signal Lamp Modul	68
TL-EX-FH-0101 Y1/M Series Board Back Type/Butoon/Switch/Signal Lamp Modul	70

# Contents

TL-EX-FH-0102 (M) SERIES Board Back Type/Butoon/Switch/Signal Lamp Modul	72
TL-EX-FH-0101-MD SERIES Board Back Type/Butoon/Switch/Signal Lamp Modul	74
TL-EX-FH-0101-AMD SERIES Board Back Type/Butoon/Switch/Signal Lamp Modul	76
TL-EX-FH-0101-S/MD SERIES Board Back Type/Butoon/Switch/Signal Lamp Model	78
TL-EX-FH-0101 Y1/MD SERIES Board Back Type/Butoon/Switch/Signal Lamp Modul	80
TL-EX-FH-0102-MD SERIES Board Back Type/Butoon/Switch/Signal Lamp Modul	82
TL-EX-FH-0105 SERIES Explosion-proof Switch Button	84
TL-EX-FH-0105-A SERIES Explosion-proof Switch Button	86
TL-EX-FH-0105-B1 SERIES Explosion-proof Switch Button	88
TL-EX-FH-0107 SERIES Signal Lamp Model	90
TL-EX-FH-0109 Series Explosion-proof Ammeters	91
TL-EX-FH-0160 SERIES Anticorrosive Moulded Case Circuit Breaker	93
TL-EX-FH-0161 SERIES Anticorrosive Moulded Case Circuit Breaker	94
TL-EX-FH-0161-L SERIES Anticorrosive Moulded Case Circuit Breaker	97
TL-EX-FH-0173 SERIES Anticorrosive Moulded Case Circuit Breaker	100
TL-EX-RT-XX SERIES Blind Puling	101
TL-EX-KP-XX SERIES Coupler Fitling	102
TL-EX-R-X1-X2-X3 SERIES Gland Reducer	103
TL-EX-NP-XX SERIES Nipple	104
TL-EX-ST-XX SERIES Sealing Fitling	105
TL-EX-JB1-X-X-X SERIES Junction Box	106
TL-EX-ACGX SERIES Cable Gland	107
TL-EX-CGX SERIES Cable Gland	109

## TL-EX-FH-BSP01-Series Explosion-proof Plug and Sockets

### 1 Application and Features

- Explosion protection  
ATEX
- Application in hazardous area  
Zone 1 & 2,  
Zone 21 & 22
- Flame-proof type enclosure, four types of enclosure, eight kinds of current classes:  
10A, 16A, 25A, 32A, 50A, 63A, 100A, 125A, and four kinds of pole numbers: 2P, 3P, 4P, 5P.
- Reliable interlocking function: The plug can be pulled out only after the power switch is off, and the power switch can be on only after the plug is inserted into the cavity.
- Contact performance of the plug is reliable. The plug sleeve in the socket has an elastic shutter spring sleeve, which not only makes the plug self-cleaning but also ensures small contact resistance and low temperature rise. At the same time, it also reduces the required insertion and extraction force to the minimum.
- The design of the shutter spring sleeve ensures the normal function of plug and socket and permanent self-cleaning.
- This model includes a timer with different working voltages, set to different colors to avoid mistaken insertion.



### 2 Nomenclature

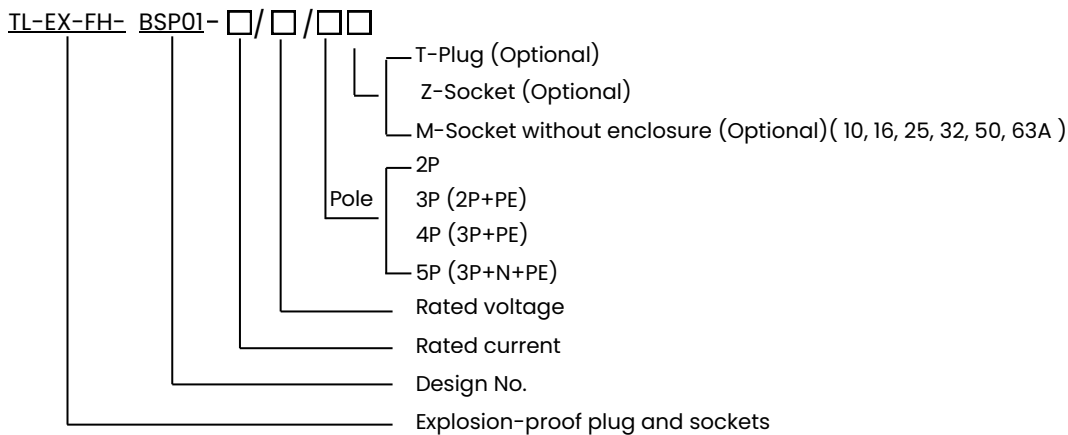

Flame-proof thread type cover  
Easy to install and disassemble



Stainless steel nameplate  
Clear and fine lettering



Different working voltage product  
with different indication color



Fix the dust cover with  
stainless steel chain  
Prevent falling off  
Protect contact copper  
rod and flame-proof joint

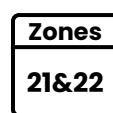
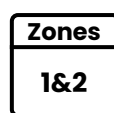
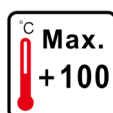
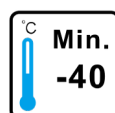

## TL-EX-FH-BSP01-Series Explosion-proof Plug and Sockets

### 3 Technical Parameter

















































<b>Ex marking</b>	<b>Gas</b>	Ⓔ II 2G Ex db IIC T6 Gb		Ex db IIC T6 Gb	
	<b>Dust</b>	Ⓔ II 2D Ex tb IIIC T80°C Db		Ex tb IIIC T80°C Db	
<b>Conformity to standards</b>		IEC 60079-0, IEC 60079-1, IEC 60079-11, IEC 60079-31 EN 60079-0, EN 60079-1, EN60079-11, EN 60079-31			
<b>Enclosure material</b>		Aluminum alloy enclosure, powder coated surface, industrial gray with dark lines texture (RAL7035)			
<b>Exposed fasteners</b>		Stainless steel			
<b>Rated voltage</b>		24, 36V DC (10, 16A) 100-130V AC, 200-250V AC, 380-415V AC, 480-500V AC, 600-690V AC			
<b>Rated current</b>		10A, 16A, 25A, 32A, 50A, 63A, 100A, 125A			
<b>Poles</b>		2P (2P+PE), 3P (2P+PE), 4P (3P+PE), 5P (3P+N+PE)			
<b>Frequency</b>		50Hz/60Hz			
<b>Degree of protection</b>		IP66			
<b>Cable entry</b>		10, 16, 25, 32, 50, 63A: -60°C ~ +45°C, -60°C ~ +65°C (Please specify when ordering) 100, 125A: -60°C ~ +50°C			
<b>Cable outer diameter (mm)</b>	<b>Rated current</b>	10, 16A	25, 32A	50, 63A	100, 125A
	<b>Wire diameter</b>	2.5-4 mm <sup>2</sup>	4-6 mm <sup>2</sup>	10-16 mm <sup>2</sup>	25-35 mm <sup>2</sup>
	<b>Weight (kg)</b>	2.2	3.3	6.6	25.2

### 4 Selection Table

Rated current (A)	Rated voltage (V)	Pole	Schematic diagram	h	Color	Outlet and Inlet thread	Cable outer dia. (mm)
10, 16	DC24	2P		-	Purple	Plug: 1-M25X1.5 1-NPT3/4 Socket: 2-M25X1.5 2-NPT3/4	ø9-ø14
	DC36			-	White		
	DC24	2P+PE		12	Purple		
	DC36			12	White		
	AC100-130			4	Yellow		
	AC200-250			6	Blue		
	AC480-500	3P+PE		4	Yellow		
	AC600-690			9	Blue		
	AC380-415			6	Red		
	AC480-500			7	Black		
	AC600-690	3P+N+PE		5	Black	Plug: 1-M32X1.5 1-NPT1 Socket: 2-M32X1.5 2-NPT1	ø11-ø18
	AC100-130			4	Yellow		
	AC200-250			9	Blue		
	AC380-415			6	Red		
	AC100-130			7	Black		
	AC200-250			5	Black		

## TL-EX-FH-BSP01-Series Explosion-proof Plug and Sockets

### 4 Selection Table

Rated current (A)	Rated voltage (V)	Pole	Schematic diagram	h	Color	Outlet and Inlet thread	Cable outer dia. (mm)
25, 32	AC200-250	2P+PE		6	 Blue	Plug: 1-M32X1.5 1-NPT1 Socket: 2-M32X1.5 2-NPT1	φ11-φ18
	AC200-250	3P+PE		9	 Blue		
	AC380-415			6	 Red		
	AC480-500			7	 Black		
	AC600-690			5	 Black		
	AC208-250	3P+N+PE		9	 Blue		
	AC380-415			6	 Red		
	AC480-500			7	 Black		
	AC600-690			5	 Black		
50, 63	AC200-250	3P+PE		9	 Blue	Plug: 1-M50X1.5 1-NPT1 1/2 Socket: 2-M40X1.5 2-NPT1 1/4	φ17 φ30
	AC380-415			6	 Red		
	AC480-500			7	 Black		
	AC600-690			5	 Black		
	AC208-250	3P+N+PE		9	 Blue		φ14 φ23
	AC380-415			6	 Red		
	AC480-500			7	 Black		
	AC600-690			5	 Black		
100, 125	AC200-250	3P+PE		9	 Blue	Plug: 1-M50X1.5 1-NPT1 1/2 Socket: 2-M63X1.5 3-M63X1.5 2-NPT2 3-NPT2	φ18 φ33
	AC380-415			6	 Black		
	AC480-500			7	 Black		
	AC600-690			5	 Black		
	AC380-415	3P+N+PE		6	 Red		φ24 φ38
	AC480-500			7	 Black		
	AC600-690			5	 Black		



## TL-EX-FH-BSP01-Series Explosion-proof Plug and Sockets

### 5 Outline and Installation Dimension (Dimensions in mm)

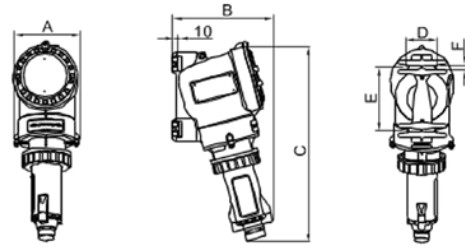
Size(mm) Type	A	B	C	D	E	F
TL-EX-FH-BSP01-16	106	164	334	52	105	7
TL-EX-FH-BSP01-32	126	195	384	77	140	9
TL-EX-FH-BSP01-63	187	238	469	87	180	13
TL-EX-FH-BSP01-125	360	256	693	328	315	/

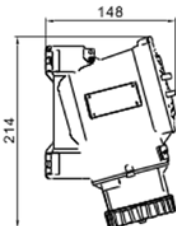
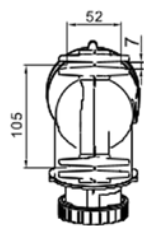
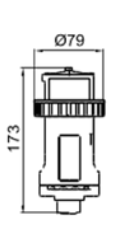
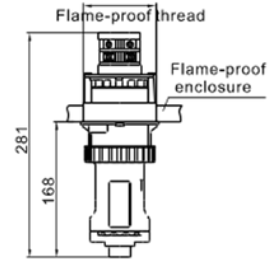
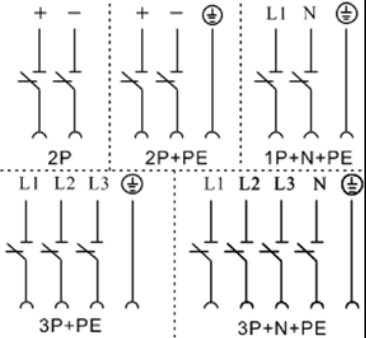
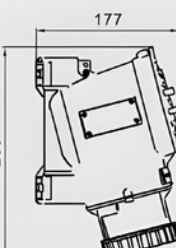
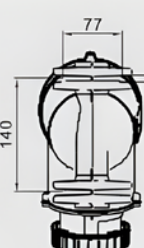
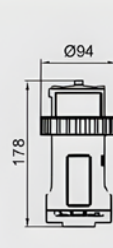
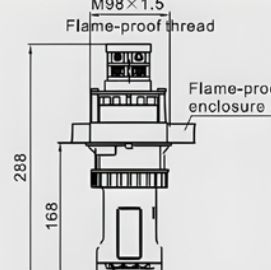
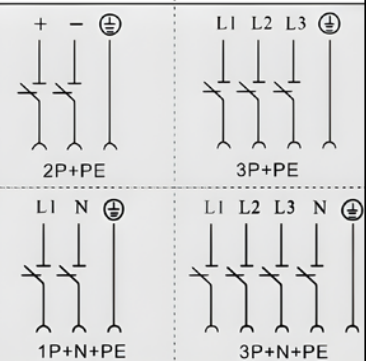
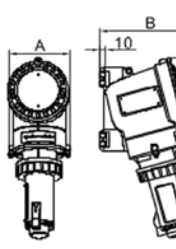
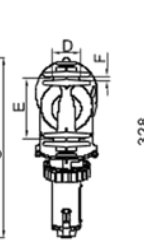
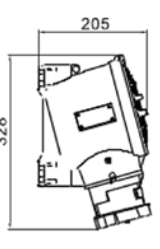
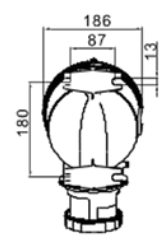
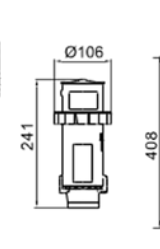
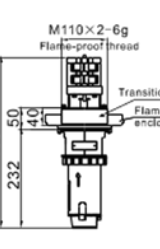
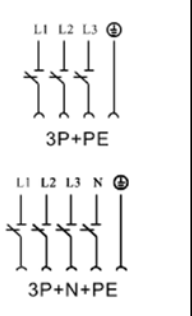
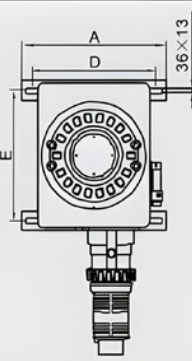
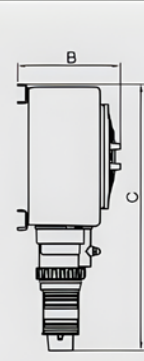
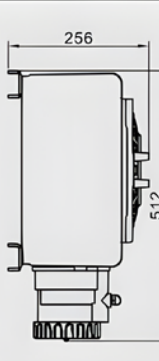
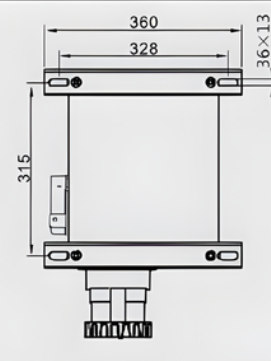

TL-EX-FH-BSP01-16(32)

 <p>148 214</p>	 <p>52 105</p>	 <p>Ø79 173</p>	 <p>M84×1.5 Flame-proof thread Flame-proof enclosure 281 168</p>	 <p>2P 2P+PE 1P+N+PE 3P+PE 3P+N+PE</p>		
<p>Z-Socket TL-EX-FH-BSP01-16/3(16/2; 16/4)</p>		<p>M-Socket without enclosure</p>				
 <p>177 260</p>	 <p>77 140 9</p>	 <p>Ø94 178</p>	 <p>M98×1.5 Flame-proof thread Flame-proof enclosure 288 168</p>	 <p>2P+PE 3P+PE 1P+N+PE 3P+N+PE</p>		
<p>Z-Socket TL-EX-FH-BSP01-16/5(32/3, 32/4, 32/5)</p>		<p>M-Socket without enclosure</p>				
 <p>A 10 B C</p>	 <p>D E F</p>	 <p>205 328</p>	 <p>186 87 13</p>	 <p>Ø106 241</p>	 <p>M110×2-6g Flame-proof thread Transition piece Flame-proof enclosure 408 50 40 232</p>	 <p>3P+PE 3P+N+PE</p>
<p>TL-EX-FH-BSP01-63</p>		<p>Z-Socket</p>		<p>T-Plug</p>		
 <p>A D E 36×13</p>	 <p>B C</p>	 <p>256 512</p>	 <p>360 328 36×13 315</p>	 <p>Ø120 Ø84 293</p>		
<p>TL-EX-FH-BSP01-125</p>		<p>Z-Socket</p>		<p>T-Plug</p>		

## TL-EX-FH-BSP03-Series Explosion-proof Plug and Sockets

### 1 Application and Features

- Explosion protection  
ATEX
- Application in hazardous area  
Zone 1 & 2,  
Zone 21 & 22
- Flame-proof type and dust explosion-proof type structure, used with explosion-proof instruments and meters. Three kinds of pole numbers: 2P, 3P, 4P.
- After the plug and socket are connected by thread locking mode, they have anti-vibration anti-loosening and anti-misplugging functions.
- Contact performance of the plug is reliable.
- The plug sleeve in the socket has an elastic shutter spring sleeve, which not only makes the plug self-cleaning but also ensures small contact resistance and low temperature rise.
- At the same time, it reduces the required insertion and extraction force to a minimum.
- The design of the shutter spring sleeve ensures normal plug and socket function and permanent self-cleaning.
- The product has timing function; different working voltages are set to different colors to prevent wrong insertion.
- Cable wiring for plug.

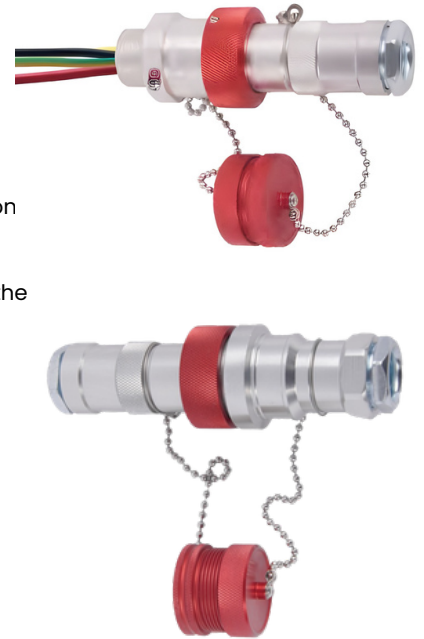



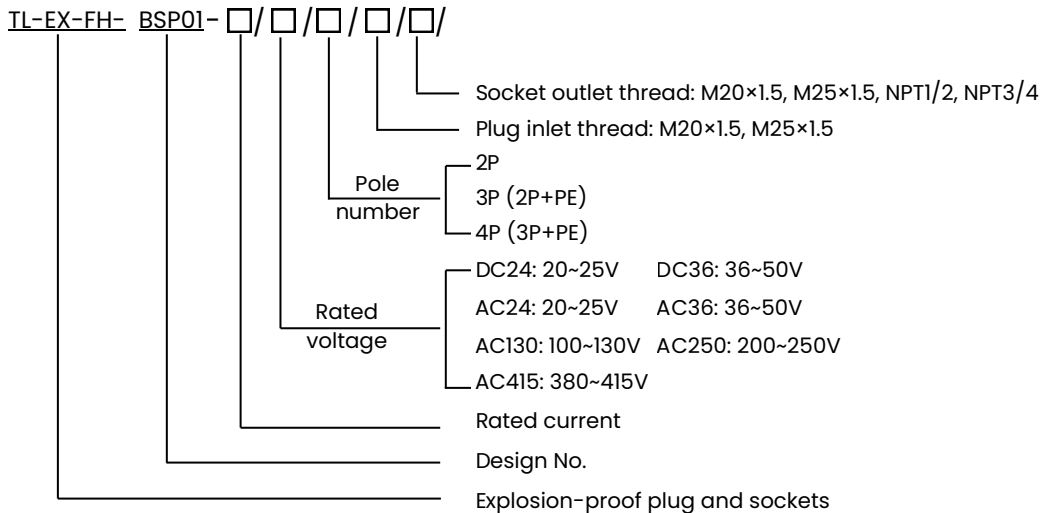



























### 2 Nomenclature



<b>Ex marking</b>	<b>Gas</b>	Ex db IIC Gb	
	<b>Dust</b>	Ex tb IIIC Db	
<b>Conformity to standards</b>	IEC 60079-0, IEC 60079-1, IEC 60079-11, IEC 60079-31 EN 60079-0, EN 60079-1, EN60079-11, EN 60079-31		
<b>Exposed fasteners</b>	Stainless steel		
<b>Rated voltage</b>	20~25V DC, 36~50V DC		
	20~25V AC, 36~50V AC, 100~130V AC, 200~250V AC, 380~415V AC		
<b>Rated current</b>	6A, 10A, 16A		
<b>Pole</b>	2P, 3P (2P+PE), 4P (3P+PE) requencey		
<b>Frequency</b>	50Hz/60Hz		
<b>Degree of protection</b>	IP66, IP68		
<b>Ambient temperature</b>	6A, 10A: -40°C ~ +70°C 16A: -40°C ~ +60°C		
<b>Thread specification</b>	<b>Inlet thread/cable outer diameter (mm)</b>	M20×1.5 / Ø4-Ø10 (Default)	NPT1/2 / Ø4-Ø10
		M25×1.5 / Ø5.5-Ø12	NPT3/4 / Ø5.5-Ø12
	<b>Thread</b>	Socket: M20×1.5 (Default), M25×1.5, NPT1/2, NPT3/4 Plug: M20×1.5 (Default), M25×1.5	

## TL-EX-FH-BSP03-Series Explosion-proof Coupler

### 4 Selection Table

Rated voltage (V)	Pole	Schematic diagram	h	Color	
AC20-25	2P		/	 Purple	
AC36-50			12	 White	
AC20-25			10	 Purple	
AC36-50				 White	
AC20-25	2P+PE		/	 Purple	
AC36-50			12	 White	
AC20-25			10	 Purple	
AC36-50				 White	
AC100-130			4	 Yellow	
AC200-250			6	 Blue	
AC20-25		3P+PE		/	 Purple
AC36-50				12	 White
AC20-25			10	 Purple	
AC36-50				 White	
AC100-130			4	 Yellow	
AC200-250			9	 Blue	
AC380-415			6	 Red	

### 5 Outline and Installation Dimension (Dimensions in mm)

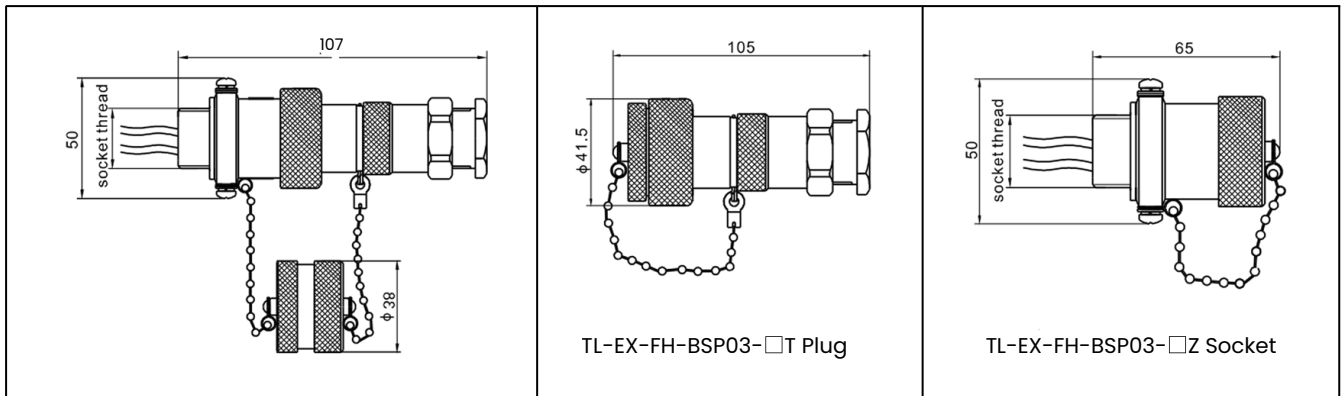

### 6 Wiring Diagram

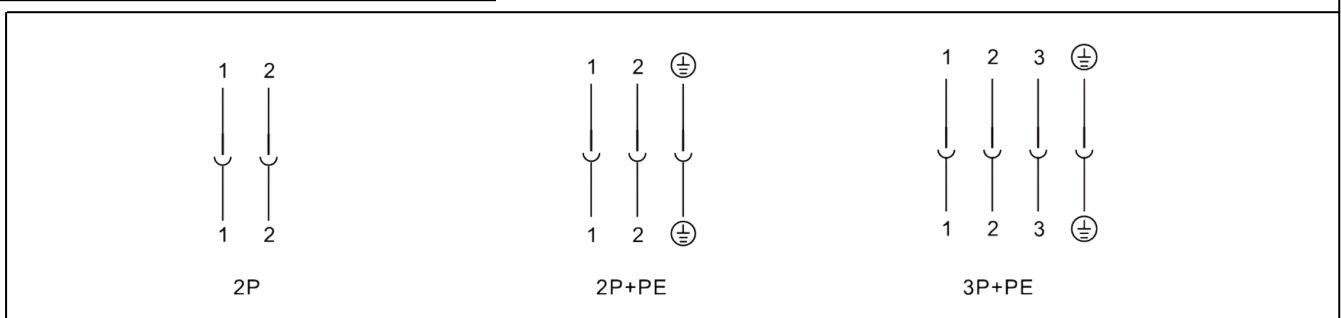

## TL-EX-FH-BSP07-Series Explosion-proof Plug and Sockets

### 1 Application and Features

- Explosion protection  
ATEX
- Application in hazardous area  
Zone 1 & 2,  
Zone 21 & 22
- Increased safety type enclosure, four types of enclosure, three kinds of current: 16A, 32A, 63A, 125A; three kinds of pole numbers: 3P, 4P, 5P.
- Reliable interlocking function: The plug can be pulled out only after the power switch is off, and the power switch can be turned on only after the plug is inserted into the cavity.
- Contact performance of the plug is reliable. The plug sleeve in the socket has an elastic shutter spring sleeve, which not only makes the plug self-cleaning but also ensures small contact resistance and low-temperature rise. At the same time, it reduces the required insertion and extraction force to the minimum. The design of the shutter spring sleeve ensures the normal function of plug and socket and permanent self-cleaning.
- The product has timing function, different working voltages are set in different colors to prevent wrong insertion.
- The socket is equipped with a padlock, which can be locked when not in use, preventing the socket from being opened.



### 2 Nomenclature

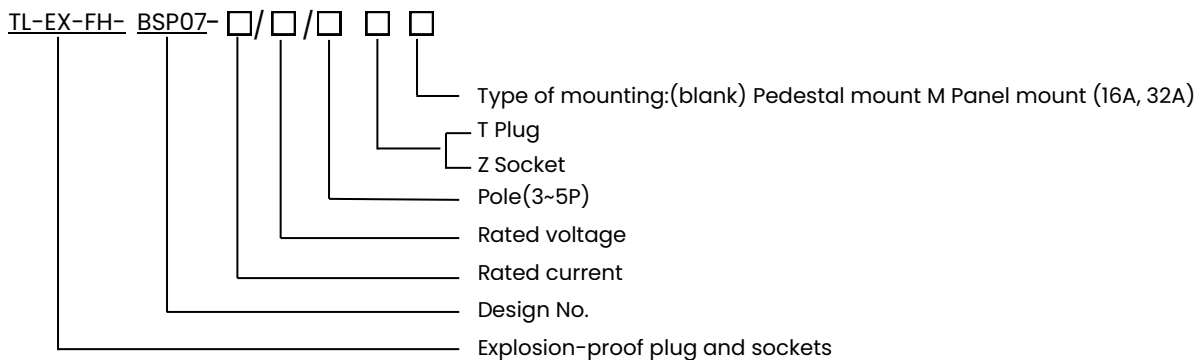





### 3 Technical Parameter

Ex marking	Gas	16A	Ex db eb IIC T6/T5 Gb		
		32A	Ex db eb IIC T5/T4 Gb		
		63A	Ex db eb IIC T5 Gb		
		125A	Ex db eb IIC T4 Gb		
	Dust	16A, 32A 63A, 125A	Ex tb IIIC T80°C Db		
Conformity to standards		IIEC 60079-0, IEC 60079-1, IEC 60079-7, IEC 60079-31			
Enclosure material		Socket enclosure: GRP, resistant to 7J impact, antistatic Plug enclosure: Nylon (PA66)			
Exposed fasteners		Stainless steel			
Rated voltage		16A	16A, 32A, 63A, 125A		
		110~130V AC	200~250V AC, 380~415V AC, 480~500V AC, 600~690V AC		
Rated current		16A, 32A, 63A, 125A			
Frequency		50Hz/60Hz			
Degree of protection		IP66, IP68			
Ambient temperature		-45°C ~ +50°C, -45°C ~ +53°C, -45°C ~ +55°C, -45°C ~ +60°C, -45°C ~ +65°C			
Cable entries	Socket inlet thread	16A	32A	63A	125A
	Outer diameter of Socket cable (mm)	2×M25×1.5	2×M40×1.5	2×M50×1.5	2×M63×1.5
	Outer diameter of plug cable (mm)	Ø8-Ø14	Ø15-Ø26	Ø15-Ø26	Ø37-Ø44
	Wire diameter	3P: Ø7-Ø16 / 4(5)P: Ø9-Ø19	Ø12-Ø28	Ø19-Ø28	Ø34-Ø53
	Weight (kg)	2.5-4 mm <sup>2</sup>	6 mm <sup>2</sup>	16 mm <sup>2</sup>	35-50 mm <sup>2</sup>
		1,9	2,8	9,9	-

## TL-EX-FH-BSP07-Series Explosion-proof Plug and Sockets

### 4 Outline and Installation Dimension (Dimensions in mm)



#### Product Version (16A/3P)

TL-EX-FH-BSP07-16/3	Clock h and voltage
 (Z)	110-130V 1P+N+PE Yellow
 (T)	200-150V 1P+N+PE Blue
 (M)	<b>Wiring Diagram (16A/3P)</b>
	 1P+N+PE

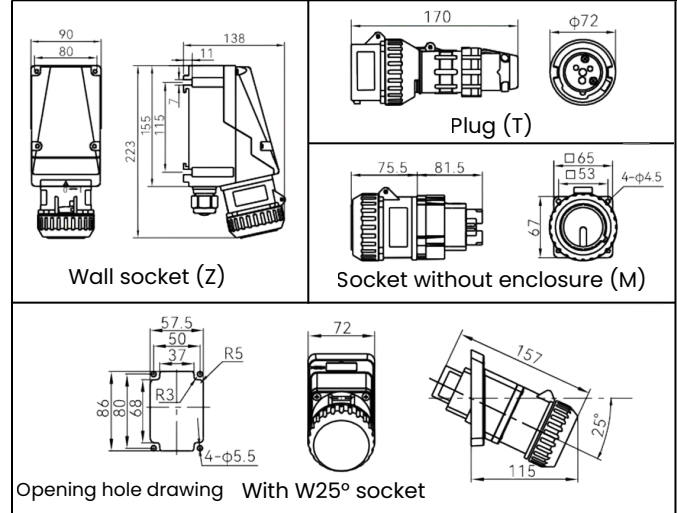
#### Outline and Installation Dimension (16A/3P)





#### Product Version (16A/3P)

TL-EX-FH-BSP07-16/4	Clock h and voltage
 (Z)	200-250V 3P+PE Blue
 (T)	380-415V 3P+PE Blue
 (M)	480-500V 3P+PE Black
	600-690V 3P+PE Black

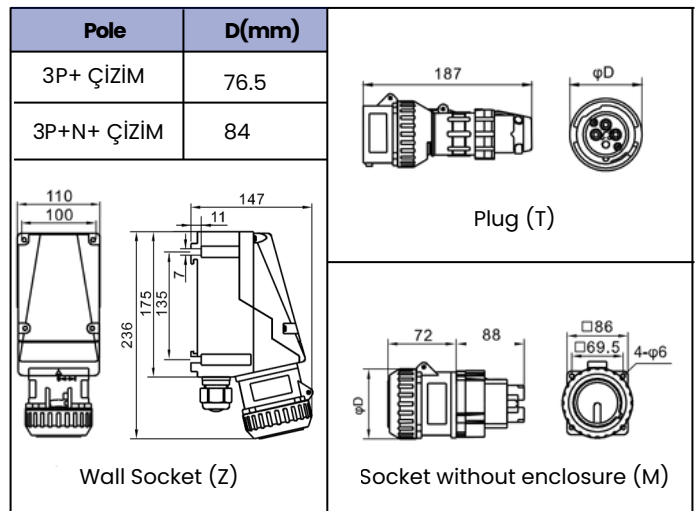
#### Outline and Installation Dimension (16A/4(5)P)







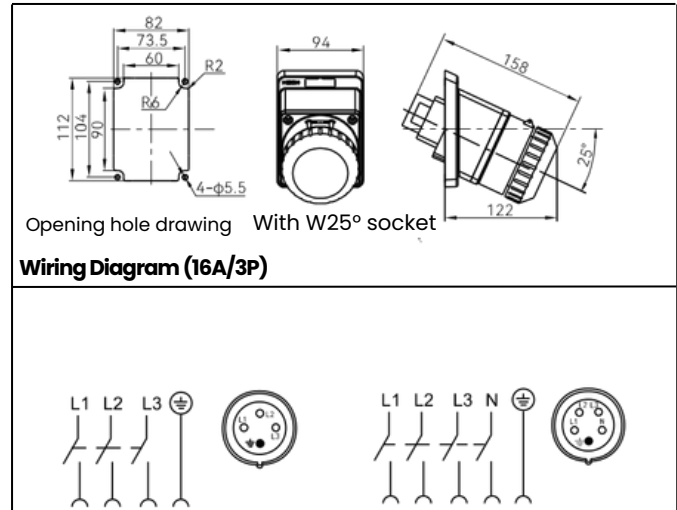







#### Product Version (16A/3P)

TL-EX-FH-BSP07-16/5	Clock h and voltage
 (Z)	200-250V 3P+N+PE Blue
 (T)	380-415V 3P+N+PE Blue
 (M)	480-500V 3P+N+PE Black
	600-690V 3P+N+PE Black













## TL-EX-FH-BSP07-Series Explosion-proof Plug and Sockets

### Product Version (32A/4P)

TL-EX-FH-BSP07-32/4	Clock h and voltage
 (Z)	 200-250V  3P+PE Blue h4
 (T)	 380-415V  3P+PE Red h6
 (M)	 480-500V  3P+PE Black h7
 (M)	 600-690V  3P+PE Black h5

### Product Version (32A/5P)

TL-EX-FH-BSP07-32/5	Clock h and voltage
 (Z)	 200-250V  3P+N+PE Blue h4
 (T)	 380-415V  3P+N+PE Red h6
Wall socket (Z)	 480-500V  3P+N+PE Black h7
Plug (T)	 600-690V  3P+N+PE Black h5

### Outline and Installation Dimension (32A/4(5)P)

Pole	D(mm)
2P, 2P+⊕	95
3P+⊕	95
3P+N+⊕	100

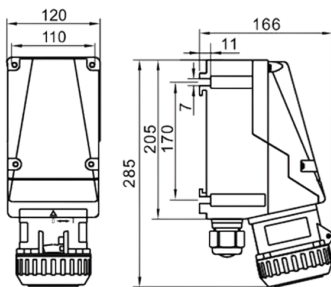

Wall socket (Z)

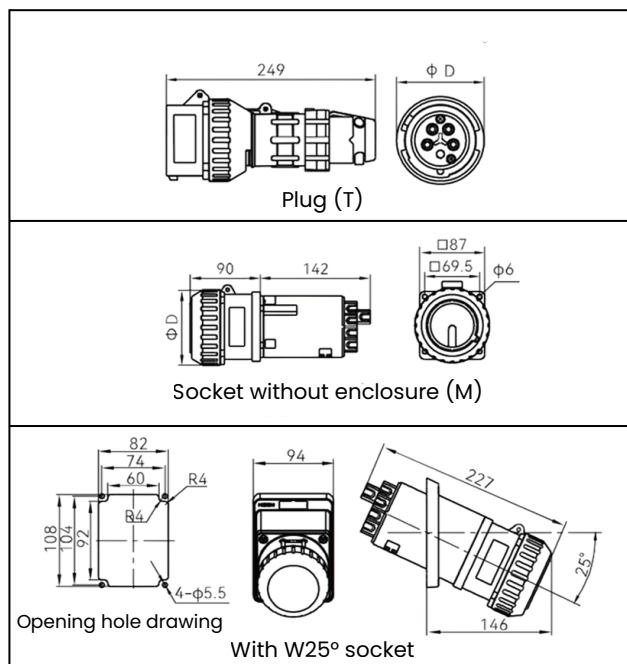

Plug (T)

Socket without enclosure (M)

Opening hole drawing





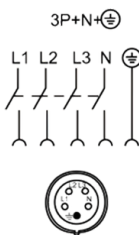
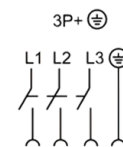





With W25° socket

### Wiring Diagram (32A/4(5)P)











## TL-EX-FH-BSP07-Series Explosion-proof Plug and Sockets

### Product Version (63A/4P)

TL-EX-FH-BSP07-63/4	Clock h and voltage
 Wall socket(Z)	 200-250V  3P+PE Blue
	 380-415V  3P+PE Blue
 Plug(T)	 480-500V  3P+PE Black
	 600-690V  3P+PE Black

### Product Version (63A/5P)

TL-EX-FH-BSP07-63/5	Clock h and voltage
 Wall socket(Z)	 200-250V  3P+N+PE Blue
	 380-415V  3P+N+PE Blue
 Plug(T)	 480-500V  3P+N+PE Black
	 600-690V  3P+N+PE Black



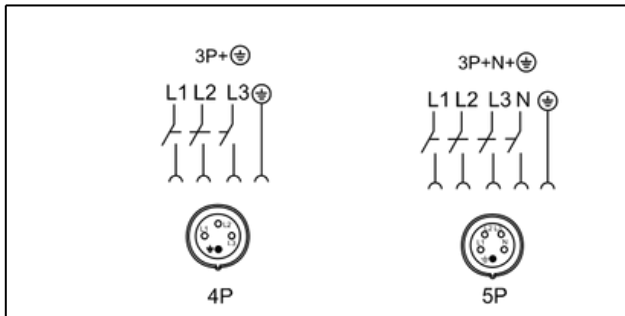



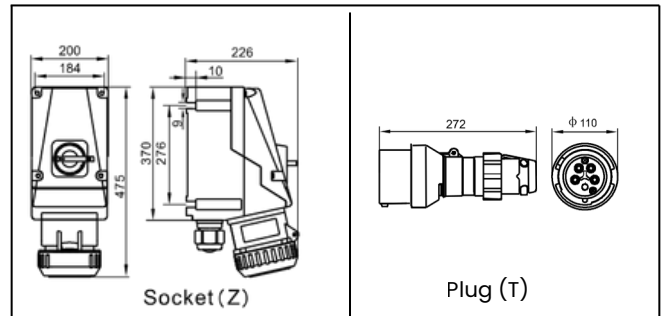





### Wiring Diagram (63A/4(5)P)



### Outline and Installation Dimension (63A/4(5)P)



### Product Version (125A/4(5)P)

TL-EX-FH-BSP07-125/4	Clock h and voltage
 Wall socket(Z)	 200-250V  3P+PE Blue
	 380-415V  3P+PE Blue
 Plug(T)	 480-500V  3P+PE Black
	 600-690V  3P+PE Black
TL-EX-FH-BSP07-125/5	Clock h and voltage
 220/380V  240/450V 3P+N+PE Red	

### Wiring Diagram (125A/4(5)P)

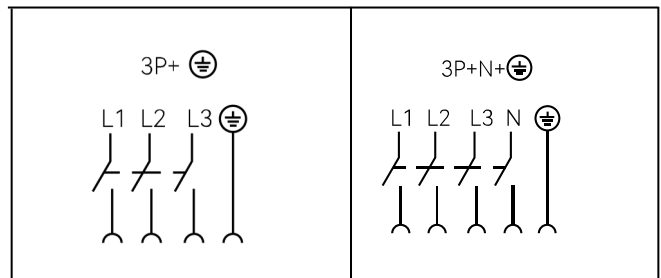

### Outline and Installation Dimension (125A/4(5)P)

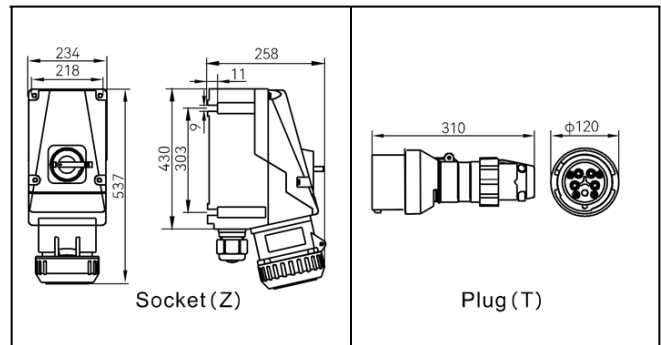

## TL-EX-FH-DP03-Series Explosion-proof Electrical Apparatus

### 1 Application and Features

- Explosion protection ATEX
- Application in hazardous area Zone 1 & 2, Zone 21 & 22
- Three types of explosion protection: Ex db IIB, Ex db IIB+H2, Ex tb IIC
- The enclosure can be equipped with miniature circuit breakers (MCB) or molded case circuit breakers (MCCB), leakage circuit breakers, contactors, thermal relays, PLCs, control transformers, soft starters, control buttons, indicator lights, push switches, potentiometers, Voltmeter, ammeter, tachometer, terminal block, etc.
- The enclosure with hinges and handle, convenient for installation and maintenance.
- Protect the flame-proof surface when operating.
- The circuit breaker using metal handle with frozen-resistant and can be equipped with a padlock,
- The enclosures can be combined and installed to meet the various requirements of power distribution systems.
- Can be customized according to user requirements, meet the certificate use restrictions. The number of elements and the maximum number of holes size needs to meet the requirements of power dissipation and mechanical strength of the housing. Please specify the special requirements when ordering.



### 2 Nomenclature

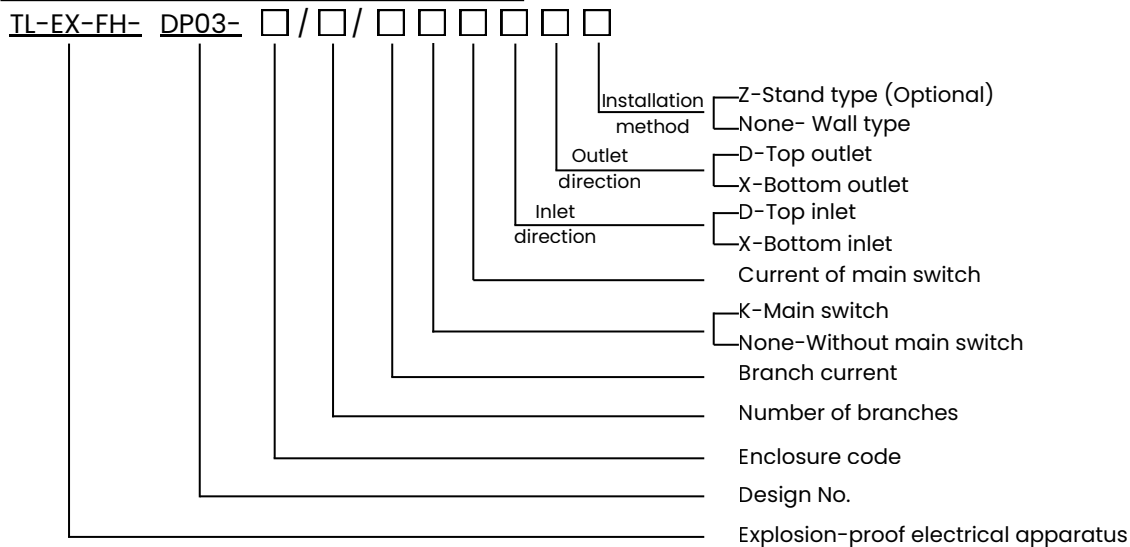

#### Note:

1. Please select the model according to the "Nomenclature" above, and specify all the technical parameters;
2. Please provide the electrical schematic diagram;
3. Please specify the number, specification and position of the cable entry holes, and ex-proof cable glands provided by user;
4. The rain shade is customizable by requirements.

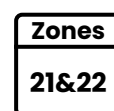
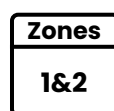
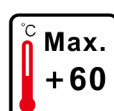

## TL-EX-FH-DP03-Series Explosion-proof Electrical Apparatus

### 3 Technical Parameter

<b>Ex marking</b>	<b>Gas</b>	⊕II 2G Ex db IIB T6/T5/T4 Gb	Ex db IIB T6/T5/T4 Gb
		⊕II 2G Ex db[ ia/ib] IIB T6/T5/T4 Gb	Ex db[ia/ib] IIB T6/T5/T4 Gb
		⊕II 2G Ex db IIB+H2 T6/T5/T4 Gb	Ex db IIB+H2 T6/T5/T4 Gb
		⊕II 2G Ex db[ia/ib] IIB+H2 T6/T5/T4 Gb	Ex db[ia/ib] IIB+H2 T6/T5/T4 Gb
	<b>Dust</b>	⊕II 2D Ex tb IIIC T80/T95/T130°C Db	Ex tb IIIC T80/T95/T130°C Db
<b>Conformity to standards</b>		IEC 60079-0, IEC 60079-1, IEC 60079-11, IEC 60079-31 EN 60079-0, EN60079-1, EN60079-11, EN60079-31	
<b>Enclosure material</b>	Enclosure	Aluminum alloy enclosure, powder coated, Industrial grey with dark lines texture (RAL7035)	
	Transparent part	Tempered glass, resistant to 4J impact	
	Rain shade	Bended steel plate surface powder coated, industrial grey with dark lines texture (RAL7035) or stainless steel 304/316, please note when needed	
<b>Exposed fasteners</b>		Stainless steel	
<b>Components</b>	Power circuit breaker	Miniature circuit breaker (MCB) or molded case circuit breaker (MCCB) and leakage circuit breaker	
	Branch switch	Miniature circuit breaker (MCB) or molded case circuit breaker (MCCB) and leakage circuit breaker	
	Terminal block	World famous brand	
	Indicator	Red, green, yellow, blue, white	
	Button	Red, green, yellow, blue, white	
	Control switch		
	AC contactor	World famous brand	
	Thermal relay	World famous brand	
	PLC programmer	World famous brand	
Soft starter	World famous brand		
<b>Rated voltage</b>		Maximum 1000V AC, 1500V DC	
<b>Rated current</b>		Maximum 1200A	
<b>Frequency</b>		50Hz/60Hz	
<b>Degree of protection</b>		IP66	
<b>Ambient temperature</b>		-20°C~+40/60°, -40°C~+40/60°C	
<b>Cable entry</b>		M□X1.5(default, exact size according to requirement) , NPT thread (optional)	
<b>Inlet direction</b>		Bottom in and bottom out, upon request	
<b>Installation method</b>		Wall type (default)	
		Stand type (optional)	

### 4 Selection Table

Type	Enclosure size	Internal size	Maximum power dissipation (Ta: +40°C)			Maximum power dissipation (Ta: +60°C)		Weight of Empty enclosure
	LxWxH	LxWxH	T6/T80°C	T5/T95°C	T4/T130°C	T6/T80°C	T5/T95°C	
TL-EX-FH-DP03-03	282X210X170	216X144X126	45W	110W	110W	45W	72W	9.0kg
TL-EX-FH-DP03-07	350X210X170	282X142X123	45W	80W	139W	45W	80W	11.5kg
TL-EX-FH-DP03-08	350X300X235	278X228X189	45W	80W	139W	45W	80W	16.6kg
TL-EX-FH-DP03-11	433X350X280	361X278X225	100W	288W	288W	100W	162W	26kg
TL-EX-FH-DP03-15	563X433X280	488X358X197	130W	365W	365W	130W	225W	48kg
TL-EX-FH-DP03-19	720X563X280	630X473X182	200W	448W	448W	200W	380W	85kg
TL-EX-FH-DP03-21	720X563X350	626X469X257	210W	690W	690W	210W	400W	95kg

## TL-EX-FH-DP03-Series Explosion-proof Electrical Apparatus

### 5 Outline and Installation Dimension (Dimensions in mm)

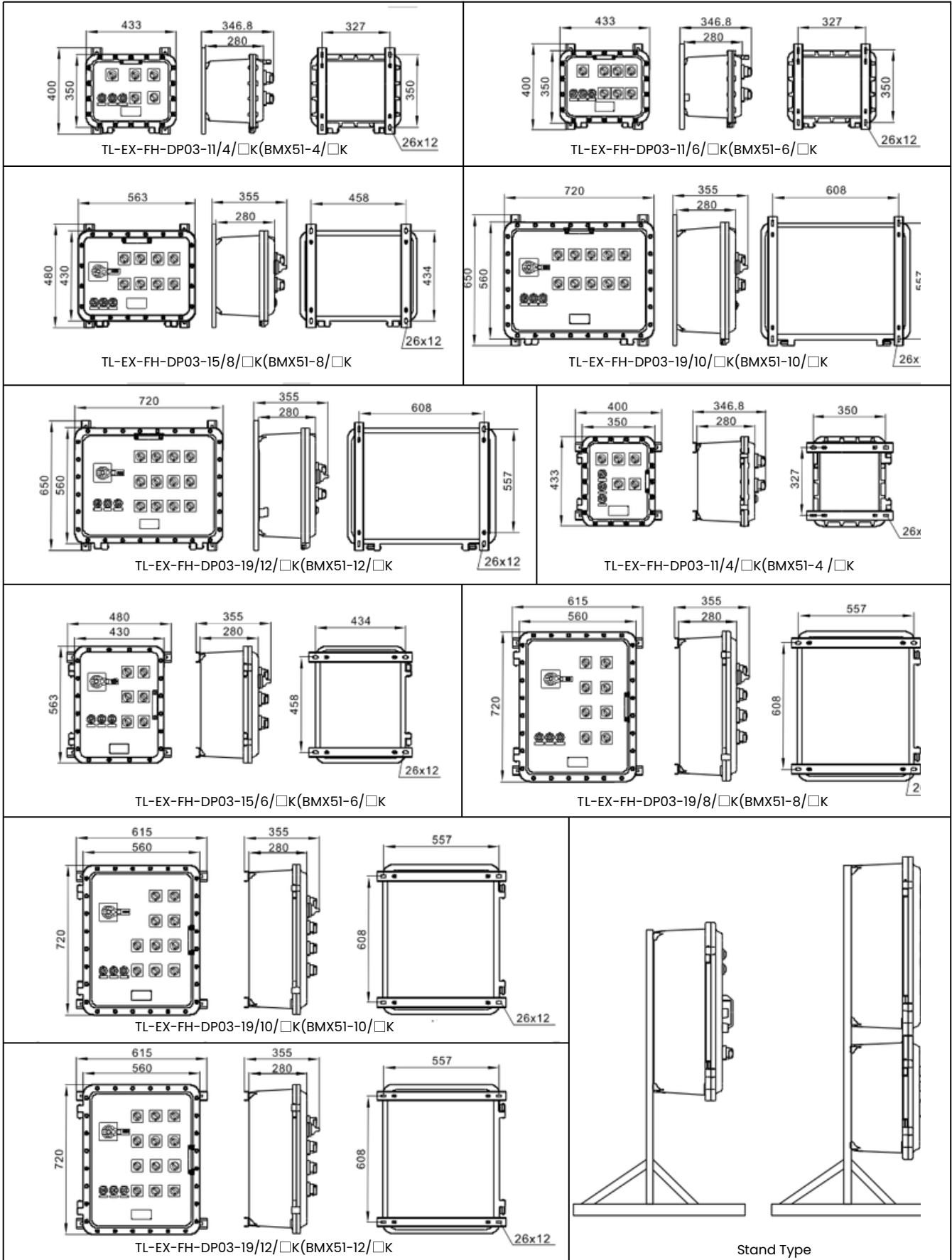

## TL-EX-FH-DP05-Series Explosion-proof Electrical Apparatus (Circuit Breaker)

### 1 Application and Features

- Explosion protection ATEX
- Application in hazardous area Zone 1 and Zone 2, Zone 21 and Zone 22
- Three types of explosion protection: Ex db IIB, Ex db IIB+H2, Ex tb IIIC.
- The enclosure can be equipped with miniature circuit breakers (MCB) or molded case circuit breakers (MCCB), leakage circuit breakers.
- leakage protection accessories, shunt tripping device, and other protection devices are optional.
- The enclosure with hinges and handle, convenient for installation and maintenance. Protect the flame-proof surface when operating.
- The circuit breaker using metal handle with frozen-resistant and can be equipped with a padlock.



### 2 Nomenclature

TL-EX-FH- DP05- □ / □ □ □ □

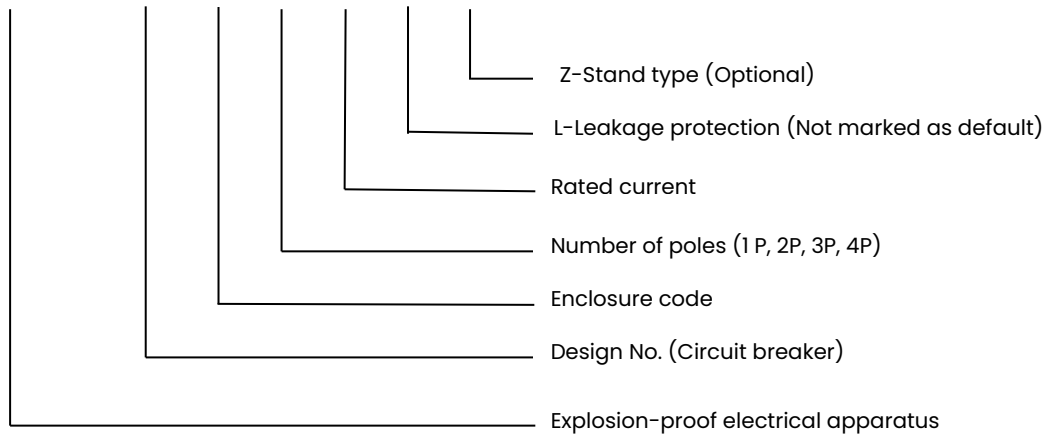

#### Note:

1. Please select the model according to the "Nomenclature" above, and specify all the technical parameters;
2. Please specify the number, specification and position of the cable entry holes, and cable entry device provided by user;
3. The rain shade is customizable by requirements.

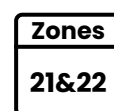
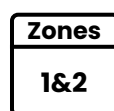
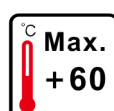
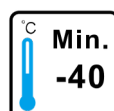

## TL-EX-FH-DP05-Series Explosion-proof Electrical Apparatus (Circuit Breaker)

### 3 Technical Parameter

<b>Ex marking</b>	<b>Gas</b>	⊕ II 2G Ex db IIB T6/T5/T4 Gb	Ex db IIB T6/T5/T4 Gb										
		⊕ II 2G Ex db IIB+H2 T6/T5/T4 Gb	Ex db IIB+H2 T6/T5/T4 Gb										
	<b>Dust</b>	⊕ II 2D Ex tb IIICT80/T95/T130°C Db	Ex tb IIIC T80/T95/T130°C Db										
<b>Conformity to standards</b>	IEC 60079-0, IEC 60079-1, IEC 60079-31 EN 60079-0, EN 60079-1, EN 60079-31												
<b>Enclosure material</b>	Enclosure	Aluminum alloy enclosure, powder coated, Industrial grey with dark lines texture (RAL7035)											
	Rain shade	Bended steel plate surface powder coated, Industrial grey with dark lines texture (RAL7035) or stainless steel 304/316, please note when needed.											
<b>Exposed fasteners</b>	Stainless steel												
<b>Components</b>	Circuit breaker	Miniature circuit breaker (MCB) or molded case circuit breaker (MCCB) and leakage circuit breaker											
	Indicator light	Red, green, yellow, blue, white, according to requirement add more											
<b>Rated voltage</b>	Maximum 1000V AC, 1500V DC												
<b>Rated current</b>	Maximum 630A												
<b>Frequency</b>	50Hz/60Hz												
<b>Degree of protection</b>	IP66												
<b>Ambient temperature</b>	-20°C~+40/60°C, -40°C ~+40/60°C												
<b>Cable entry</b>	M□ x 1.5(default, exact size according to requirement) , NPT thread (optional)												
<b>Inlet direction</b>	Bottom in and bottom out												
<b>Installation method</b>	Wall type (default)												
	Stand type ( optional)												
<b>Maximum dissipation power</b>	<b>Enclosure Size</b>	<b>Type</b>	<b>Ta:+40°C</b>						<b>Ta:+60°C</b>				<b>The weight of Empty enclosure</b>
			<b>T6/T80°C</b>		<b>T5/T95°C</b>		<b>T4/T130°C</b>		<b>T6/T80°C</b>		<b>T5/T95°C</b>		
			<b>Power</b>	<b>Current</b>	<b>Power</b>	<b>Current</b>	<b>Power</b>	<b>Current</b>	<b>Power</b>	<b>Current</b>	<b>Power</b>	<b>Current</b>	
	282X210X170	03	45W	≤63A	110W	--	110W	--	45W	≤63A	72 W	--	9.0kg
	350X210X170	07	45W	63A~100A	80W	--	139W	--	45W	63A~100A	80W	--	11.5kg
	350X300X235	08	45W	63A~100A	80W	--	139W	--	45W	63A~100A	80W	--	16.6kg
	433X350X280	11	100W	100A~250A	288W	--	288W	--	100W	100A~250A	162W	--	26kg
	563X433X280	15	130W	250A~400A	365W	--	365W	--	130W	250A~400A	225W	--	48kg
	720X563X280	19	200W	--	448W	400A~630A	448W	--	200W	--	380W	--	85kg
	720X563X350	21	210W	--	690W	--	690W	400A~630A	210W	--	400W	--	95kg

### 4 Outline and Installation Dimension (Dimensions in mm)

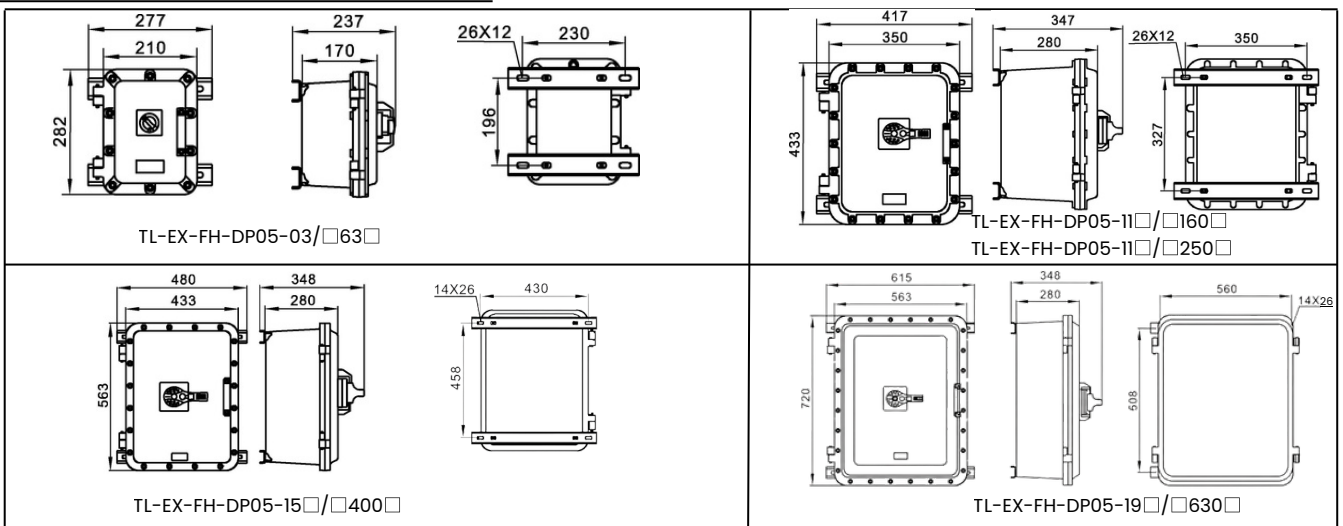

## TL-EX-FH-DP06-Series Explosion-proof Electrical Apparatus (Magnetic Starter)

### 1 Application and Features

- Explosion protection  
ATEX
- Application in hazardous area  
Zone 1 & 2,  
Zone 21 & 22
- Three types of explosion protection: Ex db IIB, Ex db IIB+H2, Ex tb IIIC
- The enclosure can be equipped with miniature circuit breakers (MCB) or molded case circuit breakers (MCCB), leakage circuit breakers, contactors, thermal relays, control buttons, indicator lights, push switches, potentiometers, Voltmeter, ammeter, tachometer, terminal block, etc.
- It's able to control the start, stop, forward and reverse rotation of the motor, and the comprehensive protection of the motor, able to multi-places control.
- The enclosure with hinges and handle, convenient for installation and maintenance. Protect the flame-proof surface when operating.
- The circuit breaker using metal handle with frozen-resistant and can be equipped with a padlock,
- The enclosures can be combined and installed to meet the various requirements of power distribution systems.
- Can be customized according to user requirements, meet the certificate use restrictions.
- The number of elements and the maximum number of holes size needs to meet the requirements of power dissipation and mechanical strength of the housing. Please specify the special requirements when ordering.



### 2 Nomenclature

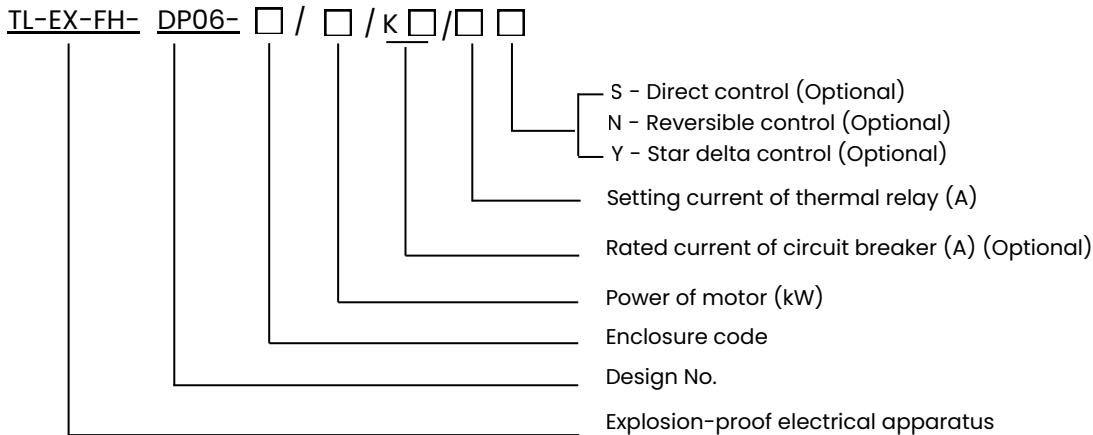

#### Note:

1. Please select the model according to the "Nomenclature" above, and specify all the technical parameters;
2. Please provide the electrical schematic diagram;
3. Please specify the number, specification and position of the cable entry holes, and ex-proof cable glands provided by user;
4. The rain shade is customizable by requirements.

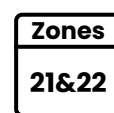
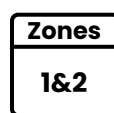
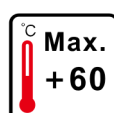
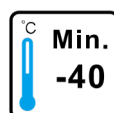

## TL-EX-FH-DP06-Series Explosion-proof Electrical Apparatus (Magnetic Starter)

### 3 Technical Parameter

<b>Ex marking</b>	<b>Gas</b>	⊕ II 2G Ex db IIB T6/T5/T4 Gb	Ex db IIB T6/T5/T4 Gb											
		⊕ II 2G Ex db IIB+H2 T6/T5/T4 Gb	Ex db IIB+H2 T6/T5/T4 Gb											
	<b>Dust</b>	⊕ II 2D Ex tb IIIC T80/T95/T130°C Db	Ex tb IIIC T80/T95/T130°C Db											
<b>Conformity to standards</b>		IEC 60079-0, IEC 60079-1, IEC 60079-31 EN 60079-0, EN 60079-1, EN 60079-31												
<b>Enclosure material</b>	Enclosure	Aluminum alloy enclosure, powder coated, Industrial grey with dark lines texture (RAL7035)												
	Transparent part	Tempered glass, resistant to 4J impact												
	Rain shade	Bended steel plate surface powder coated, industrial grey with dark lines texture (RAL7035) or stainless steel 304/316, please note when needed												
<b>Exposed fasteners</b>		Stainless steel												
<b>Components</b>	Power circuit breaker	Miniature circuit breaker (MCB) or molded case circuit breaker (MCCB) and leakage circuit breaker												
	Branch switch	Miniature circuit breaker (MCB) or molded case circuit breaker (MCCB) and leakage circuit breaker												
	Terminal block	World famous brand												
	Indicator	Red, green, yellow, blue, white												
	Button	Red, green, yellow, blue, white												
	Control switch													
	AC contactor	World famous brand												
	Thermal relay	World famous brand												
<b>Rated voltage</b>		Maximum 690V AC												
<b>Rated current</b>		Maximum 200A												
<b>Frequency</b>		50Hz/60Hz												
<b>Degree of protection</b>		IP66												
<b>Ambient temperature</b>		-20°C~+40/60°, -40°C~+40/60°C												
<b>Cable entry</b>		M□X1.5(default, exact size according to requirement) , NPT thread (optional)												
<b>Inlet direction</b>		Bottom in and bottom out, upon request												
<b>Installation method</b>		Wall type (default)												
		Stand type (optional)												
<b>Maximum dissipation power</b>	<b>Enclosure Size</b>	<b>Ta:+40°C</b>						<b>Ta:+60°C</b>				<b>The weight of Empty enclosure</b>		
		<b>Type</b>	<b>T6/T80°C</b>		<b>T5/T95°C</b>		<b>T4/T130°C</b>		<b>T6/T80°C</b>		<b>T5/T95°C</b>			
	<b>Power</b>		<b>Current</b>	<b>Power</b>	<b>Current</b>	<b>Power</b>	<b>Current</b>	<b>Power</b>	<b>Current</b>	<b>Power</b>	<b>Current</b>			
	282X210X170	03	45W	--	110W	--	110W	--	45W	--	72 W		--	9.0kg
	350X210X170	07	45W	≤40A	80W	≤50A	139W	--	45W	≤40A	80W		≤50A	11.5kg
	350X300X235	08	45W	≤40A	80W	≤50A	139W	--	45W	≤50A	80W		≤50A	16.6kg
	433X350X280	11	100W	≤95A	288W	≤120A	288W	--	100W	≤95A	162W		≤120A	26kg
	563X433X280	15	130W	≤150A	365W	≤200A	365W	--	130W	≤150A	225W		≤200A	48kg
720X563X280	19	200W	≤200A	448W	≤300A	448W	≤300A	200W	≤200A	380W	≤300A	85kg		
720X563X350	21	210W	≤200A	690W	≤300A	690W	≤300A	210W	≤200A	400W	≤300A	95kg		

## TL-EX-FH-DP06-Series Explosion-proof Electrical Apparatus (Magnetic Starter)

### 4 Outline and Installation Dimension (Dimensions in mm)

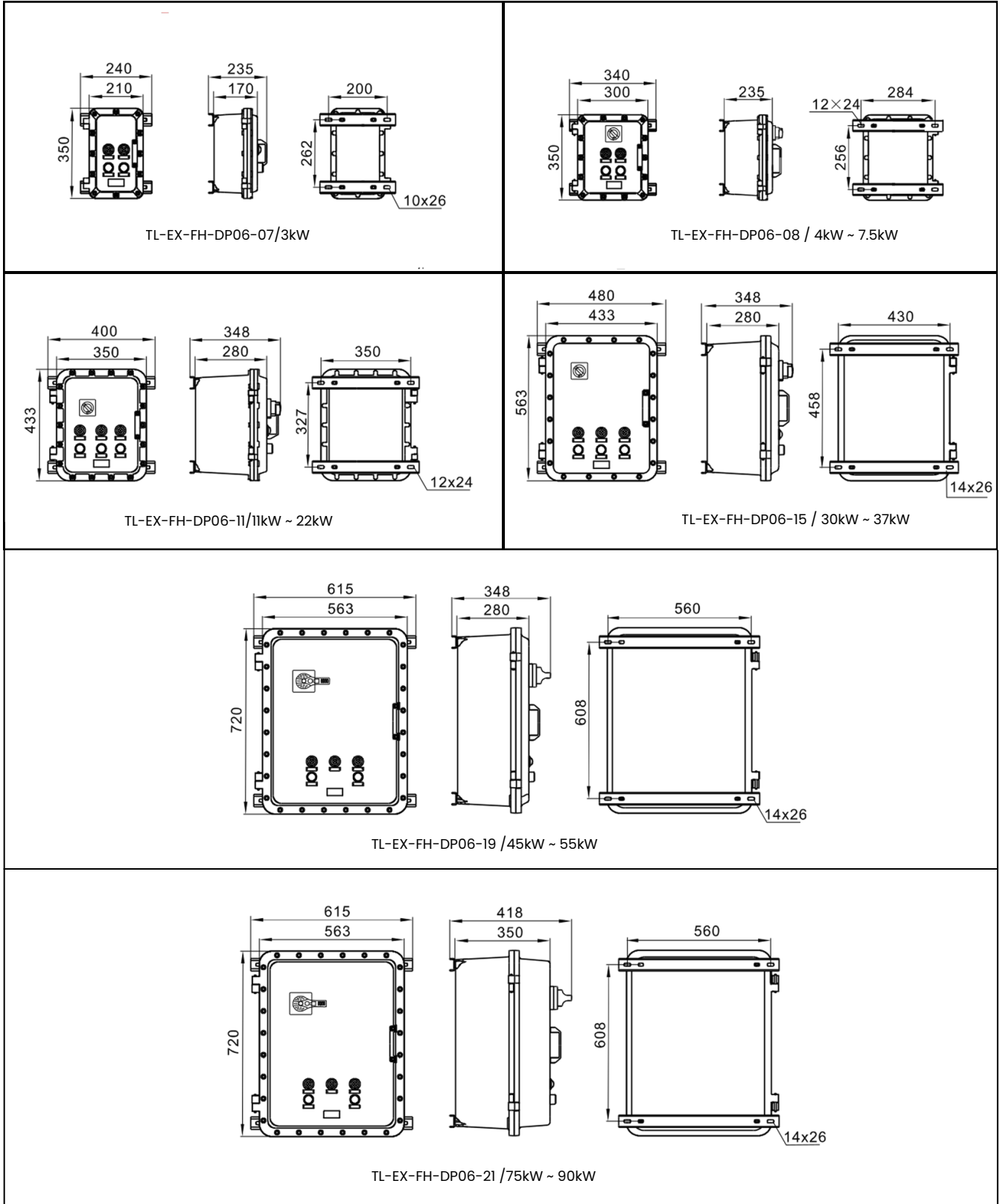

## TL-EX-FH-DP06-Series Explosion-proof Electrical Apparatus (Magnetic Starter)

### 5 Outline and Installation Dimension (Dimensions in mm)

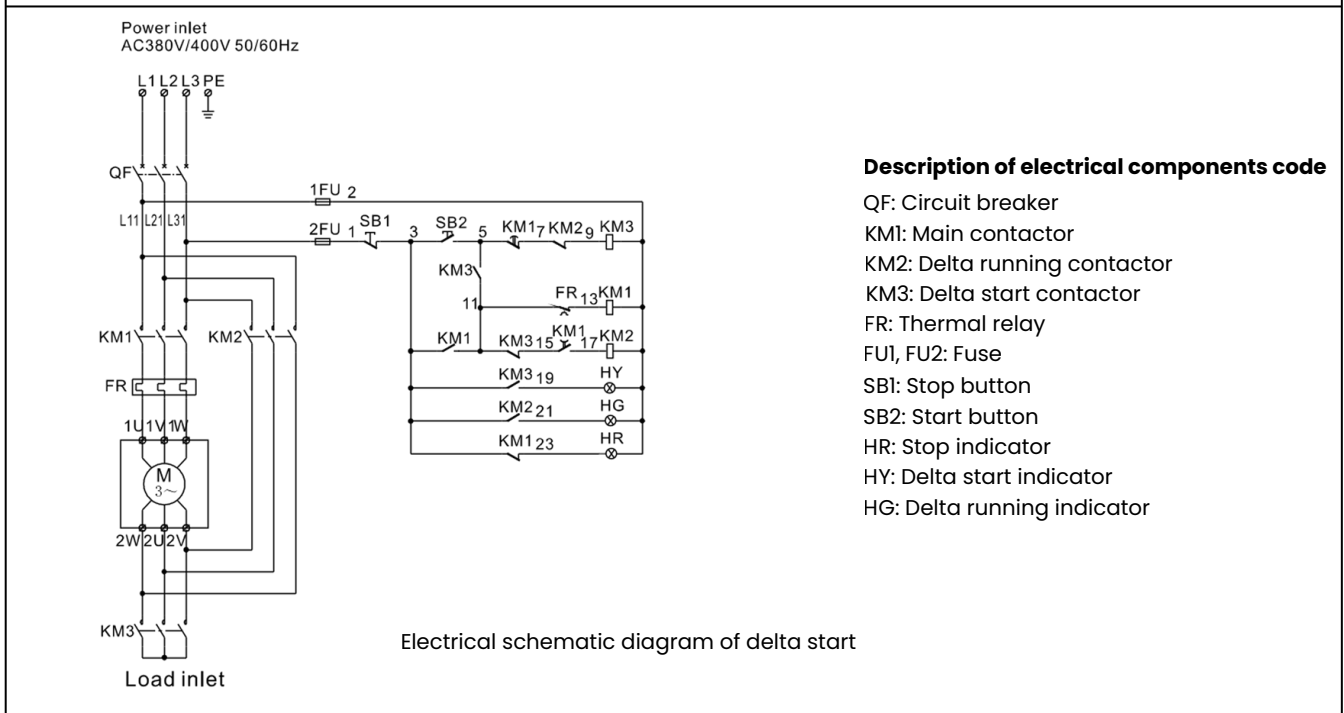
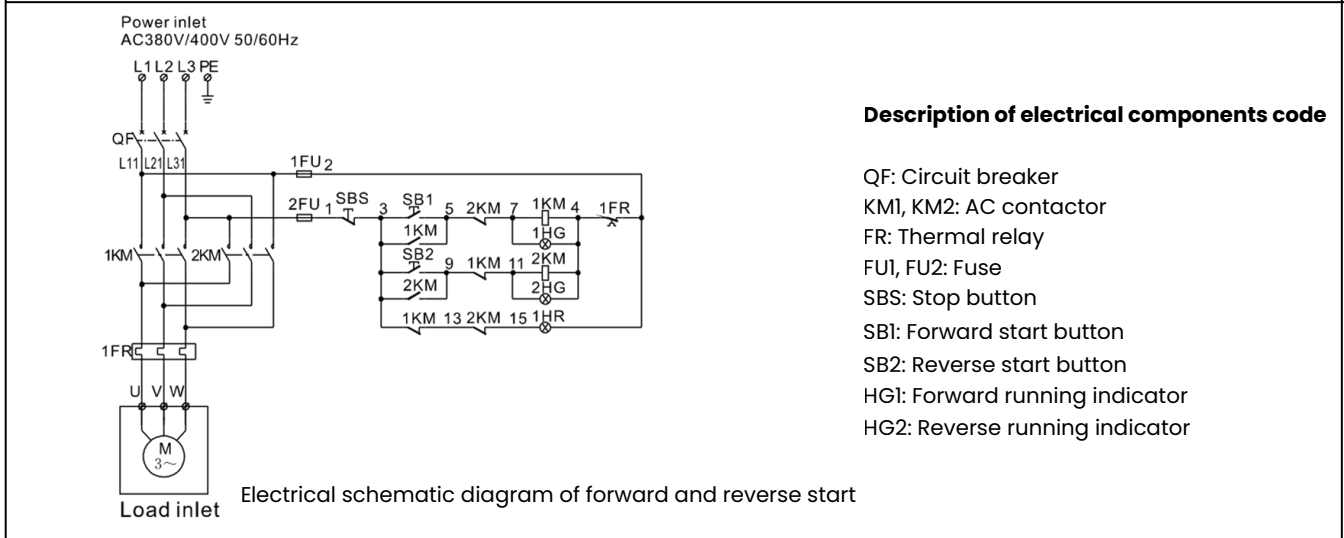
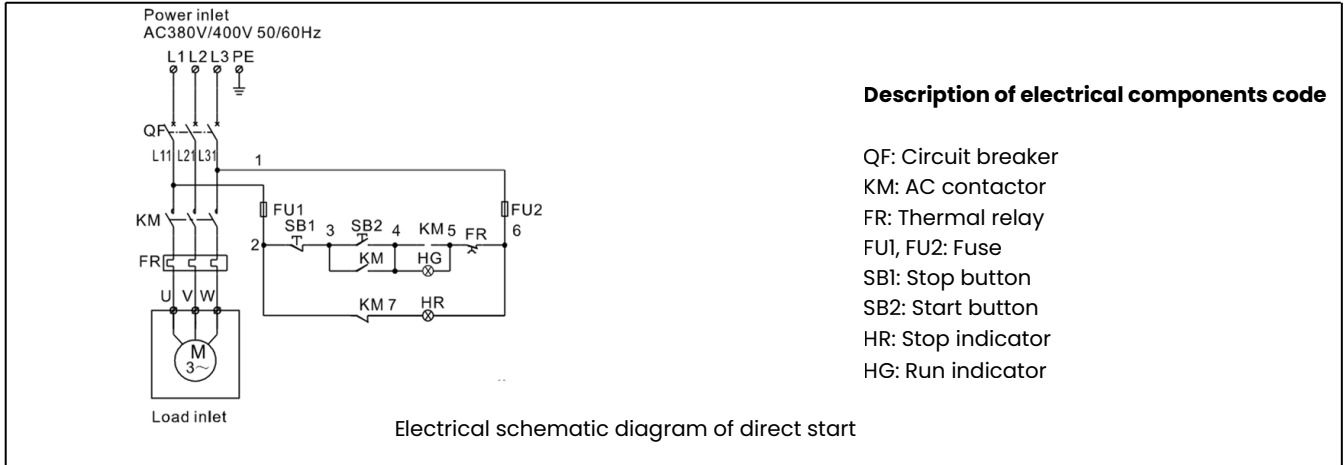

## TL-EX-FH-DP07-Series Explosion-proof Electrical Apparatus(Circuit Breaker)

### 1 Application and Features

- Explosion protection ATEX
- Application in hazardous area Zone 1 and Zone 2, Zone 21 and Zone 22
- Three types of explosion protection: Ex db IIB, Ex db IIB+H2, Ex tb IIC
- The enclosure can be equipped with transformers, buttons, indicator lights, switches, potentiometers, voltmeters, ammeters, tachometers, etc.
- The emergency stop button can be equipped with an anti-misoperation mechanism and a padlock by requirements.
- The enclosure with hinges and handle, convenient for installation and maintenance.
- Protect the flame-proof surface when operating.
- The enclosures can be combined and installed to meet the various requirements of power distribution systems.
- Can be customized according to user requirements, meet the certificate use restrictions
- The number of elements and the maximum number of holes size needs to meet the requirements of power dissipation and mechanical strength of the housing.
- The circuit breaker using metal handle with frozen-resistant and can be equipped with a padlock.
- Please specify the special requirements when ordering.

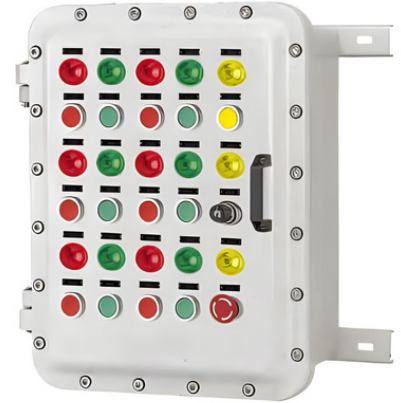

### 2 Nomenclature

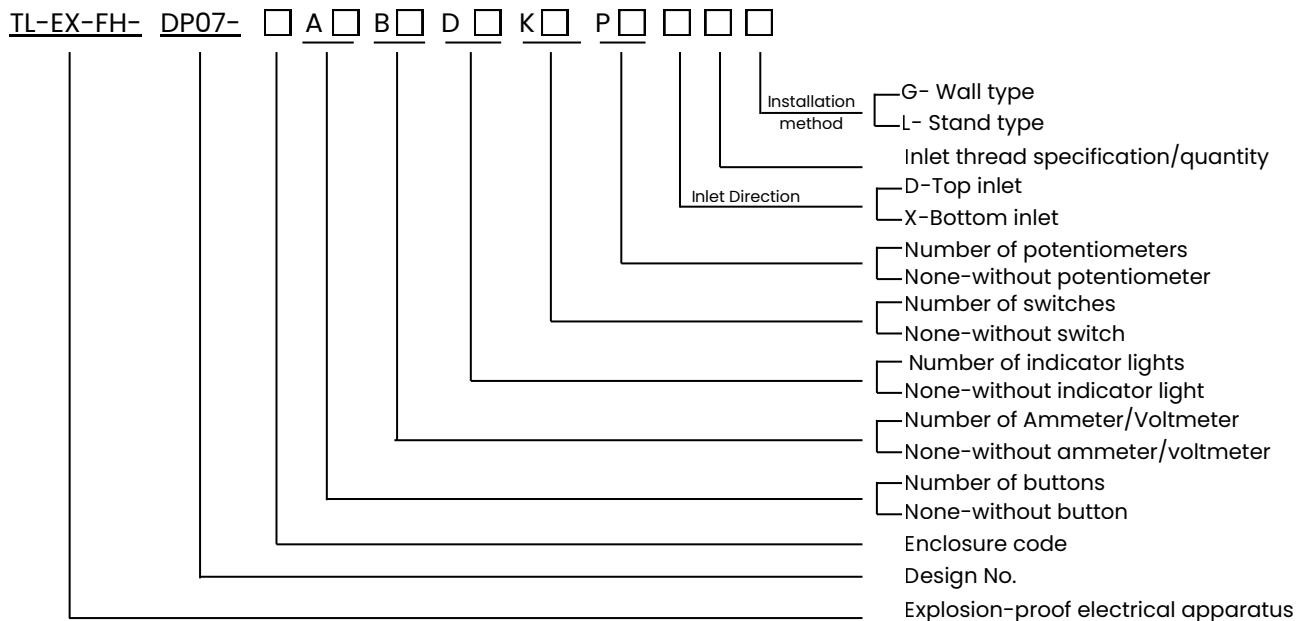

#### Note:

1. Optional components:  
TL-EX-FH-0105 explosion-proof switch button(INO&INC as default), refer to 42-48
2. Example: TL-EX-FH-0107-A2BIK1  
Components: 2 buttons, 1 ammeter, 1 control switch  
Details: 1 start button (TL-EX-FH-0105-A1101, INO+INC);  
1 stop button (TL-EX-FH-0105-A1121, INO+INC);  
1 ammeter (50/5);  
1 control switch (stop-run-start);
3. The rain shade is customizable by requirements.

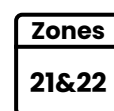
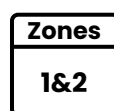
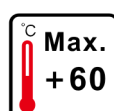
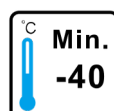

## TL-EX-FH-DP07-Series Explosion-proof Electrical Apparatus

### 3 Technical Parameter

<b>Ex marking</b>	<b>Gas</b>	⊕ II 2G Ex db IIB T6 Gb	Ex db IIB T6 Gb		
		⊕ II 2G Ex db [ ia/ib ] IIB T6 Gb	Ex db [ ia/ib ] IIB T6 Gb		
		⊕ II 2G Ex db IIB+H2 T6 Gb	Ex db IIB+H2 T6 Gb		
		⊕ II 2G Ex db [ia/ib] IIB+H2 T6 Gb	Ex db [ia/ib] IIB+H2 T6 Gb		
	<b>Dust</b>	⊕ II 2D Ex tb IIIC T80°C Db	Ex tb IIIC T80°C Db		
<b>Conformity to standards</b>		IEC 60079-0, IEC 60079-1, IEC 60079-11, IEC 60079-31 EN 60079-0, EN 60079-1, EN60079-11, EN 60079-31			
<b>Enclosure material</b>	Enclosure	Aluminum alloy enclosure, powder coated, Industrial grey with dark lines texture (RAL7035)			
	Transparent part	Tempered glass, resistant to 4J impact			
	Rain shade	Bended steel plate surface powder coated, industrial grey with dark lines texture (RAL7035) or stainless steel 304/316, please note when needed			
<b>Exposed fasteners</b>		Stainless steel			
<b>Components</b>		TL-EX-FH-0105 explosion-proof switch button			
		TL-EX-FH-0106 explosion-proof indicator			
		TL-EX-FH-0107 explosion-proof indicator			
		Control switch			
		Specifications of potentiometer according to requirements			
		The voltmeter, ammeter and tachometer are 48/72 type, specifications according to requirements			
<b>Rated voltage</b>		Maximum 415V AC			
<b>Rated current</b>		Maximum 200A			
<b>Frequency</b>		50Hz/60Hz			
<b>Degree of protection</b>		IP66			
<b>Ambient temperature</b>		-20°C~+40/60°, -40°C~+40/60°C			
<b>Cable entry</b>		M□X1.5(default, exact size according to requirement) , NPT thread (optional)			
<b>Inlet direction</b>		Bottom in and bottom out			
<b>Installation method</b>		Wall type (default)			
		Stand type (optional)			
<b>Maximum dissipation power</b>	<b>Enclosure size</b>	<b>Type / Temperature Class</b>	<b>Ta:+ 40°C T6/T80°C</b>	<b>Ta:+ 60°C T6/T80°C</b>	<b>The Weight of Empty enclosure</b>
	105X105X90	01.1	≤10A	≤16A	1.1kg
	105X160X90	01.2	≤10A	≤16A	1.5kg
	116X202X90	01.3	≤10A	≤16A	2.6kg
	282X210X170	03	45W	45W	9.0kg
	350X210X170	07	45W	45W	11.5kg
	350X300X235	08	45W	45W	16.6kg
	433X350X280	11	100W	100W	26kg
	563X433X280	15	132W	132W	48kg
	720X563X280	19	201W	201W	85kg
720X563X350	21	210W	210W	95kg	

## TL-EX-FH-DP07-Series Explosion-proof Electrical Apparatus

### 5 Outline and Installation Dimension (Dimensions in mm)

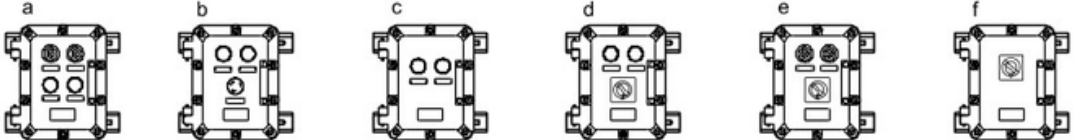
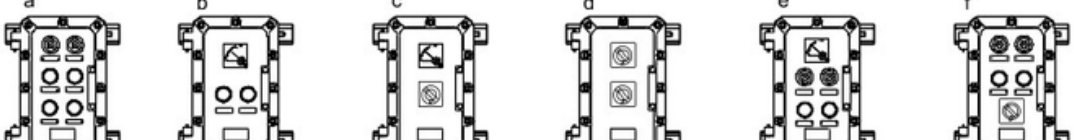
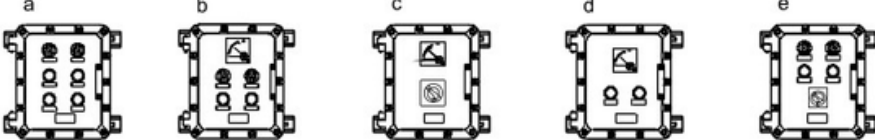
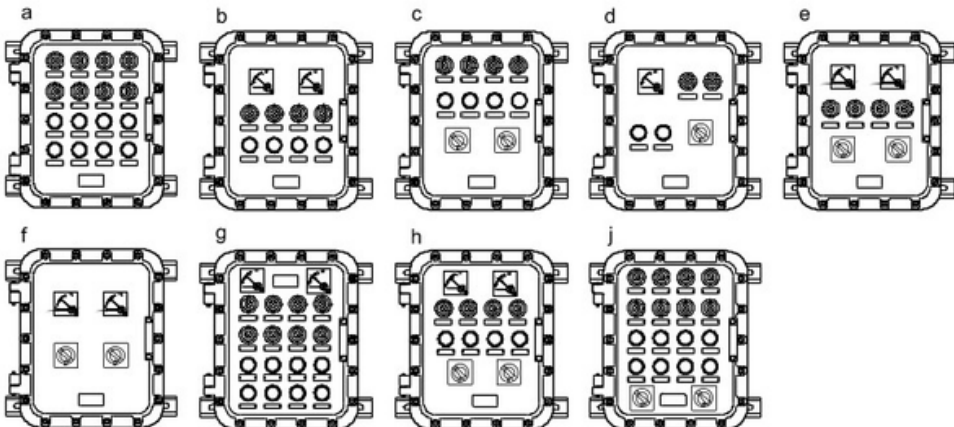
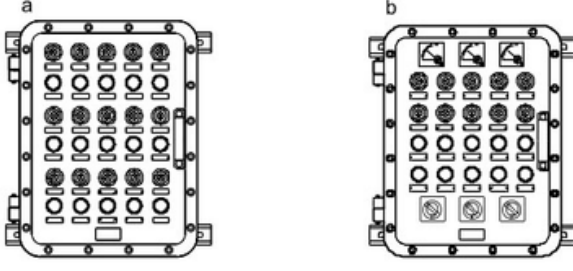
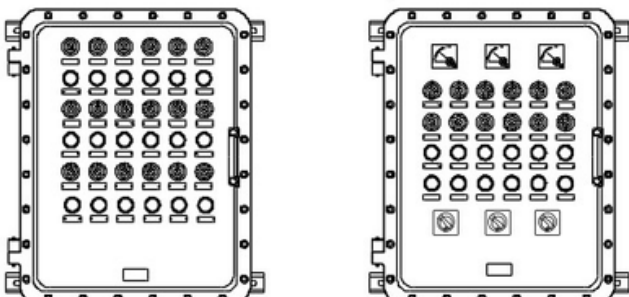
Enclosure code	Arrangement of components
03	
07	
08	
11	
15	
19/21	

# TL-EX-FH-DP11-Series Explosion-proof Electrical Apparatus (Terminal Box)

## 1 Application and Features

- Explosion protection ATEX
- Application in hazardous area Zone 1 & 2, Zone 21 & 22
- Three types of explosion protection (Ex db IIB, Ex db IIB+H2, Ex tb IIIC)
- Aluminum alloy enclosure, powder coated
- Equipped with hinges and door handle; easy to installation and maintenance, also protect the flameproof surface from cover is opening or closing.
- Can be customized upon request and able to meet the usage restrictions of the certificate
- Direction, size and quantity of cable entry can be customized and meet the requirements of dissipated power and mechanical strength of the enclosure.



## 2 Nomenclature

TL-EX-FH- DP11- □ □ / □ / □ D □ / □ L □ / □ X □ / □ R □ / □ □ □

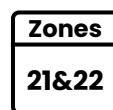
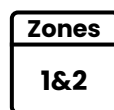
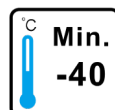
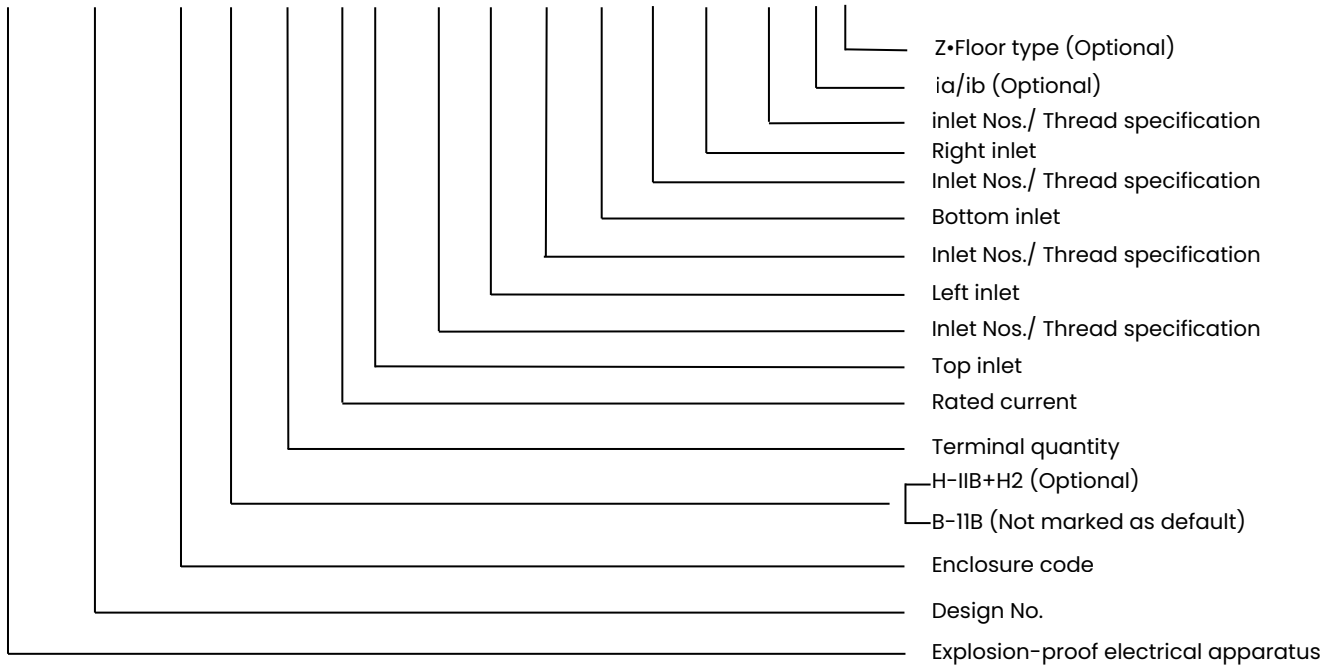

## TL-EX-FH-DP11-Series Explosion-proof Electrical Apparatus (Terminal Box)

### 3 Technical Parameter

<b>Ex marking</b>	<b>Gas</b>	Ⓔ II 2G Ex db IIB T6/T5/T4 Gb		Ex db IIB T6/T5/T4 Gb							
		Ⓔ II 2G Ex db IIB+H2 T6/T5/T4 Gb		Ex db IIB+H2 T6/T5/T4 Gb							
	<b>Dust</b>	Ⓔ II 2D Ex tb IIIC T80/T95/T130 C Db		Ex tb IIIC T80/T95/T130°C Db							
<b>Conformity to standards</b>		IEC 60079-0, IEC 60079-1, IEC 60079-31 EN 60079-0, EN 60079-1, EN 60079-31									
<b>Enclosure material</b>		Enclosure	Aluminum alloy enclosure, powder coated, Industrial grey with dark lines texture (RAL7035)								
		Rain shade	Bended steel plate surface powder coated, Industrial grey with dark lines texture (RAL7035) or stainless steel 304/316, please note when needed.								
<b>Exposed fasteners</b>		Stainless steel									
<b>Components</b>		Brand of terminal	International brand								
<b>Rated voltage</b>		Maximum 1000V AC, 1500V DC									
<b>Rated current</b>		Maximum 1200A									
<b>Frequency</b>		50Hz/60Hz									
<b>Degree of protection</b>		03,07, 08, 11, 15 -- IP66/IP67		19,21-- IP66							
<b>Ambient temperature</b>		-20°C~+40/60°C, -40°C ~+40/60°C									
<b>Inlet direction</b>		Upon request									
<b>Installation method</b>		Hanging type (Standard)									
		Floor type (Optional)									
<b>Maximum dissipation power</b>	<b>Enclosure Size</b>	<b>Type</b>	<b>Ta: +60°C</b>		<b>Ta: +40°C</b>			<b>Weight of Empty enclosure</b>			
			<b>T6/T80°C</b>		<b>T5/T95°C</b>		<b>T4/T130°C</b>				
		<b>Power</b>	<b>Rated Current</b>	<b>Power</b>	<b>Rated Current</b>	<b>Power</b>	<b>Rated Current</b>				
		282X210X170	03	45W	≤63A	110W	--		110W	--	9.0kg
		350X210X170	07	45W	63A~100A	80W	--		139W	--	11.5kg
		350X300X235	08	45W	63A~100A	80W	--		139W	--	16.6kg
		433X350X280	11	100W	100A~250A	288W	--		288W	--	26kg
		563X433X280	15	130W	250A~400A	365W	400A~800A		365W	800A~1200A	48kg
720X563X280	19	200W	250A~400A	448W	400A~800A	448W	800A~1200A	85kg			
720X563X350	21	210W	250A~400A	690W	400A~800A	690W	800A~1200A	95kg			

## TL-EX-FH-DP11-Series Explosion-proof Electrical Apparatus (Terminal Box)

### 4 Selection Table

Maximum quantity of terminals that can be installed are shown in the table below:

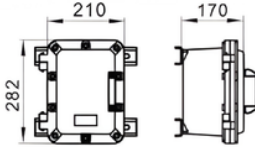
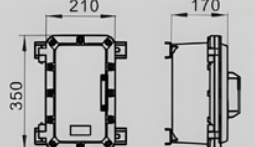
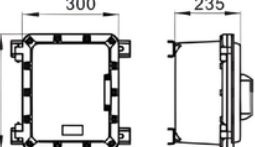
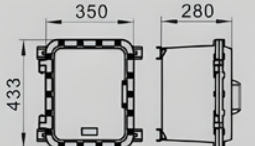
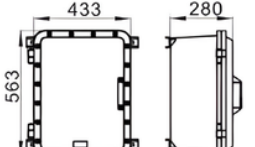
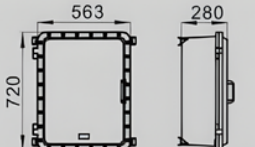
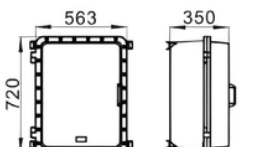
Enclosure specifications	Guideway x Terminal (specification and quantity)										
	2.5 <sup>2</sup>	4 <sup>2</sup>	6 <sup>2</sup>	10 <sup>2</sup>	16 <sup>2</sup>	35 <sup>2</sup>	70 <sup>2</sup>	120 <sup>2</sup>	185 <sup>2</sup>	240 <sup>2</sup>	300 <sup>2</sup>
	UK3N	UK5N	UK6N	UK10N	UK16N	UK35N	--	--	--	--	--
	SAK2.5EN	SAK4EN	SAK6EN	SAK10EN	SAK16EN	SAK35EN	--	--	--	--	--
03 	1X23	1X21	1X18	1X14	1X12	--	--	--	--	--	--
07 	1X31	1X29	1X24	1X19	1X16	--	--	--	--	--	--
08 	1X32	1X30	1X25	1X20	1X18	--	--	--	--	--	--
11 	1X45	1X40	1X34	1X28	1X24	1X16	--	--	--	--	--
	2X45	2X40	2X34	2X28	--	--	--	--	--	--	--
15 	1X60	1X54	1X48	1X36	1X30	1X20	--	--	--	--	--
	2X60	2X54	2X48	2X36	2X30	--	--	--	--	--	--
19 	1X90	1X80	1X70	1X60	1X40	1X25	1X25	1X14	1X10	1X8	1X5
	2X90	2X80	2X70	2X60	2X40	--	--	--	--	--	--
21 	1X90	1X80	1X70	1X60	1X40	1X25	1X25	1X14	1X10	1X8	1X5
	2X90	2X80	2X70	2X60	2X40	--	--	--	--	--	--

## TL-EX-FH-DP11-Series Explosion-proof Electrical Apparatus (Terminal Box)

### 5 Outline and Installation Dimension (Dimensions in mm)

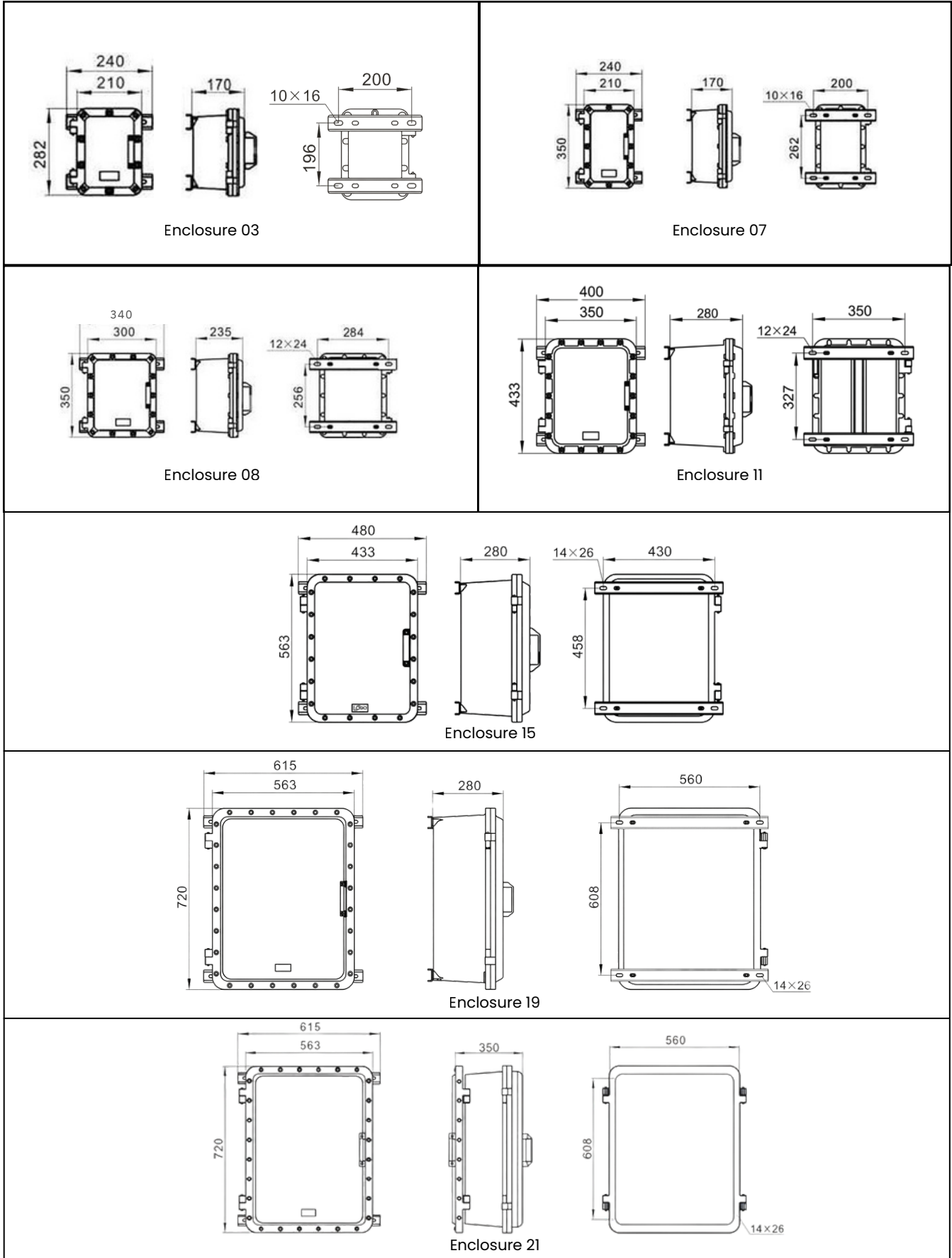

## TL-EX-FH-E03-Series Explosion-proof Electrical Enclosures

### 1 Application and Features

- Explosion protection ATEX
- Application in hazardous area Zone 1 and Zone 2, Zone 21 and Zone 22
- Die casting aluminum alloy enclosure.
- Cable entry holes, explosion-proof element hole or explosion-proof operation hole on the enclosure can be opened upon request, and comply with the restrictions on the usage of the certificate.
- The devices inside the enclosure shall meets the relevant standards of electrical equipment.
- Equipped with hinges and door handle, easy to installation and maintenance,also protect the flameproof surface from damage when the cover is opening or closing.
- Please specify the special requirements when ordering.

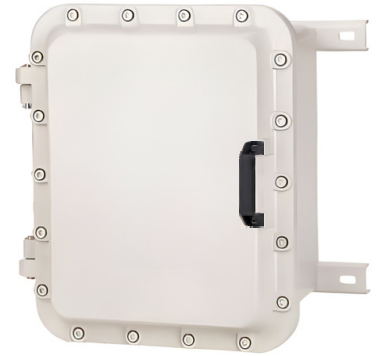

### 2 Nomenclature

TL-EX-FH - E03 - □ □ □

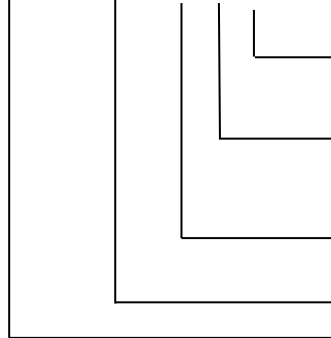

Enclosure code  
 M(D)-Distribution Box  
 K-Circuit breaker  
 J-Junction box  
 Q-Motor starter  
 H-IIB+H2 (Optional)  
 B-IIB (Not marked as default)  
 Design No.  
 Explosion-proof enclosures

**Note:** Please specify the number, specification and position of the cable entry holes, ex-proof plug can be delivered according to the requirements and ex-proof cable glands provided by user.

### 3 Technical Parameter

<b>Ex marking</b>	<b>Gas</b>	⊕ II 2G Ex db IIB Gb		Ex db IIB Gb				
		⊕ II 2G Ex db IIB+H2 Gb		Ex db IIB+H2 Gb				
	<b>Dust</b>	⊕ II 2D Ex tb IIIC Db		Ex tb IIIC Db				
<b>Conformity to standards</b>		IEC 60079-0, IEC 60079-1, IEC 60079-31 EN 60079-0, EN60079-1, EN60079-31						
<b>Material</b>	<b>Enclosure</b>	Aluminum alloy enclosure, powder coated, industrial gray with dark lines texture(RAL7035)						
	<b>Transparent parts</b>	Toughened glass, resistant to 4J impact						
<b>Exposed fastener</b>		Stainless steel						
<b>Degree of protection</b>		IP66, (J03, J07, J08, J11, J15, if sealing strip is solid silicone rubber even upto IP67)						
<b>Ambient temperature</b>	<b>Enclosure code</b>	03,07,08,11,15	Without transparent 19,21	With transparent 19,21				
	<b>Ambient temperature</b>	-20°C ~+60°C, -40°C ~+60°C			-20°C ~+60°C			
	<b>Service temperature</b>	-20°C ~ +100°, -40°C ~ +100			-20 ~ +100			
<b>Components and accessories</b>		TL-EX-FH-0105 explosion-proof button TL-EX-FH-0106 explosion-proof signal lamp TL-EX-FH-0107 explosion-proof signal lamp						
<b>Cable entries</b>		M□X1.5 as standard (upon request), NPT thread (optional)						
<b>Installation Method</b>		Hanging type (Standard) Floor type (Optional)						
<b>Weight of enclosure</b>		03#	07#	08#	11#	15#	17#	21#
		9kg	11,5kg	16,6kg	26kg	48kg	85kg	95kg





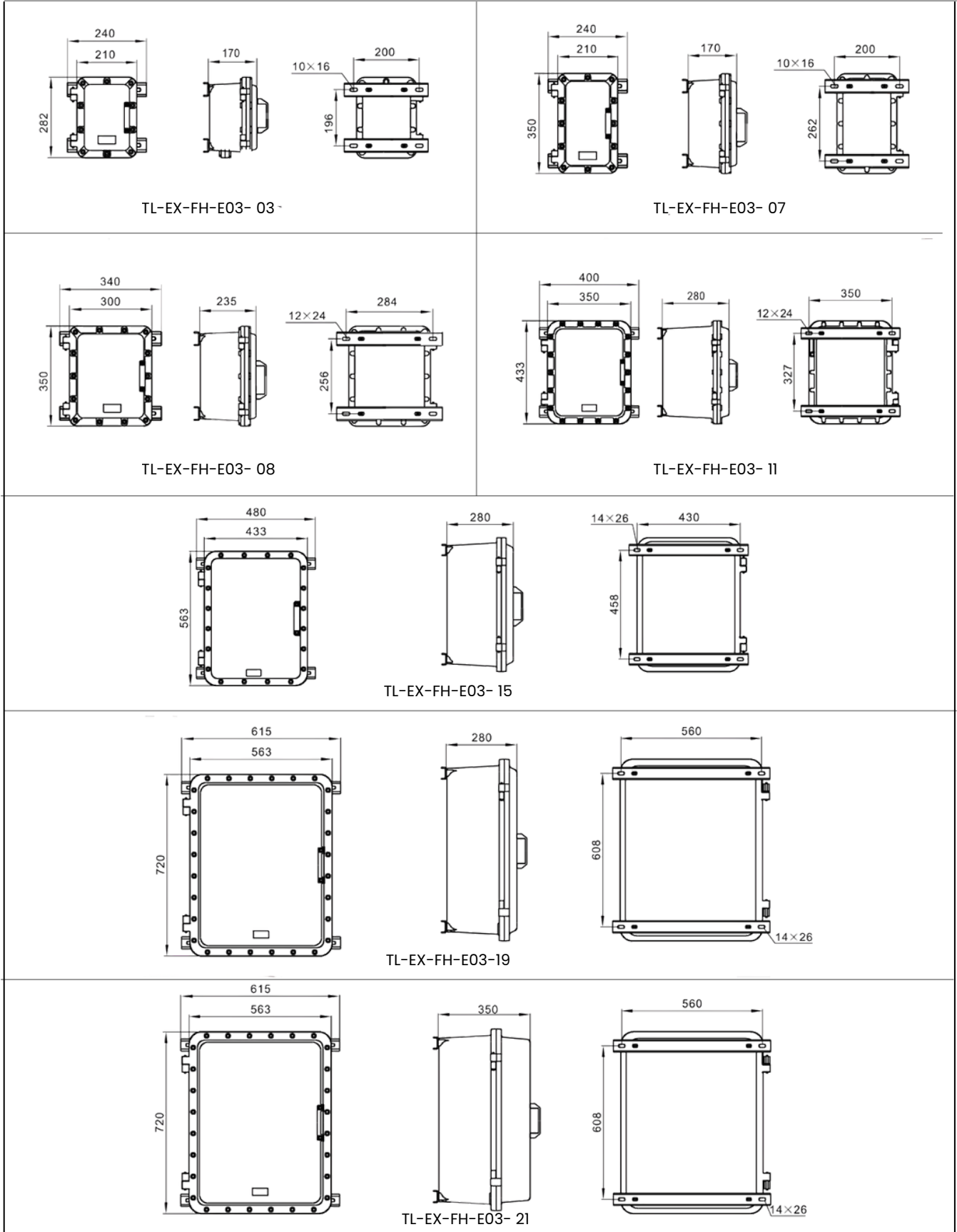





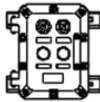

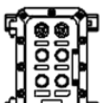

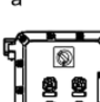
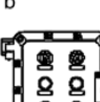

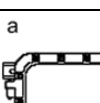
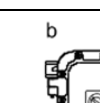
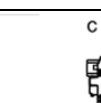
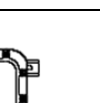
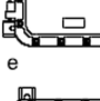
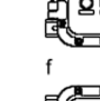
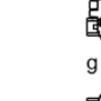

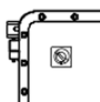
## TL-EX-FH-E03-Series Explosion-proof Electrical Enclosures

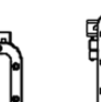
### 4 Outline and Installation Dimension (Dimensions in mm)

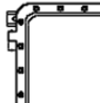

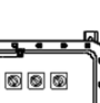
## TL-EX-FH-E03-Series Explosion-proof Electrical Enclosures

### 4 Technical Parameter

Enclosure code	Component layout				
03	a 	b 	c 		
07	a 	b 	c 		
08	a 	b 	c 		
11	a 	b 	c 	d 	
	e 	f 	g 	h 	
15	a 	b 	c 	d 	e 
19/21	a 	b 	c 	d 	
	e 	f 	g 		

Note: Other proposals can be provided upon requires.

## TL-EX-FH-DP23-Series Explosion-proof Electrical Apparatus

### 1 Application and Features

- Explosion protection  
ATEX
- Application in hazardous area  
Zone 1 & 2,  
Zone 21 & 22
- Three types of explosion protection: Ex db IIB, Ex db IIB+H2, Ex tb IIIC.
- The enclosure can be equipped with miniature circuit breakers (MCB) or molded case circuit breakers (MCCB), leakage circuit breakers, contactors, thermal relays, PLCs, control transformers, soft starters, control buttons, indicator lights, push switches, potentiometers, Voltmeter, ammeter, tachometer, terminal block, etc.
- The enclosure with hinges and handle, convenient for installation and maintenance.
- Protect the flame-proof surface when operating.
- The circuit breaker using metal handle with frozen-resistant and can be equipped with a padlock.
- The enclosures can be combined and installed to meet the various requirements of power distribution systems.
- Can be customized according to user requirements, meet the certificate use restrictions;
- The number of elements and the maximum number of holes size needs to meet the requirements of power dissipation and mechanical strength of the housing.  
Please specify the special requirements when ordering.



### 2 Nomenclature

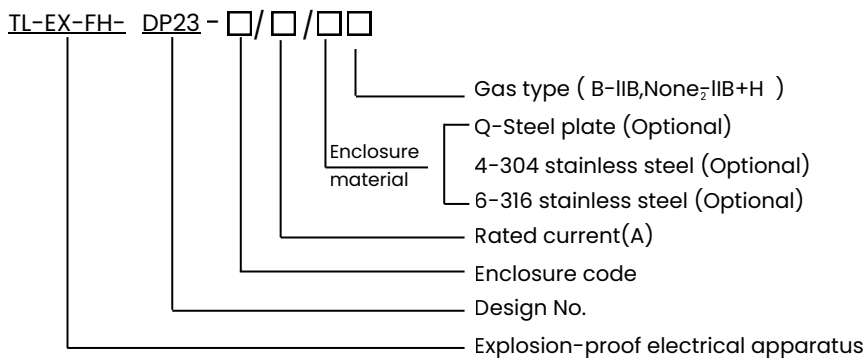

#### Note:

1. Please select the model according to the "Nomenclature" above, and specify all the technical parameters;
2. Please provide the electrical schematic diagram;
3. Please specify the number, specification and position of the cable entry holes, and ex-proof cable glands provided by user;
4. The rain shade is customizable by requirements.

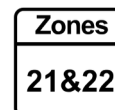
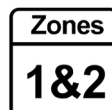
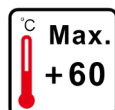
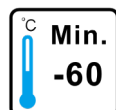

## TL-EX-FH-DP23-Series Explosion-proof Electrical Apparatus

### 3 Technical Parameter

<b>Ex marking</b>	<b>Gas</b>	⊕ II 2G Ex db IIB T6...T4 Gb	Ex db IIB T6...T4 Gb
		⊕ II 2G Ex db ( ia Ga) IIB T6...T4 Gb	Ex db ( ia Ga) IIB T6...T4 Gb
		⊕ II 2G Ex db IIB+H2 T6...T4 Gb	Ex db IIB+H2 T6...T4 Gb
		⊕ II 2G Ex db (ia Ga) IIB+H2 T6...T4 Gb	Ex db (ia Ga) IIB+H2 T6...T4 Gb
	<b>Dust</b>	⊕ II 2D Ex tb IIIC T80°C /T95°C/T130°C Db	Ex tb IIIC T80°C /T95°C/T130°C Db
		⊕ II 2D Ex tb[ia Da] IIIC T80°C/T95°C/T130°C Db	Ex tb[ia Da] IIIC T80°C/T95°C/T130°C Db
<b>Conformity to standards</b>		IEC 60079-0, IEC 60079-1, IEC 60079-11, IEC 60079-31 EN 60079-0, EN 60079-1, EN60079-11, EN 60079-31	
<b>Enclosure material</b>	Enclosure	Steel plate welding, powder coated, Industrial grey with dark lines texture (RAL7035) O stainless steel (304/316) welding, no painting or powder coated, Industrial grey with dark lines texture (RAL7035)	
	Transparent part	Tempered glass, resistant to 4J impact	
	Rain shade	Bended steel plate surface powder coated, industrial grey with dark lines texture (RAL7035) or stainless steel 304/316, please note when needed	
<b>Exposed fasteners</b>		Stainless steel	
<b>Components</b>	Power circuit breaker	Miniature circuit breaker (MCB) or molded case circuit breaker (MCCB) and leakage circuit breaker	
	Branch switch	Miniature circuit breaker (MCB) or molded case circuit breaker (MCCB) and leakage circuit breaker	
	Terminal block	World famous brand	
	Indicator	TL-EX-FH-0107 explosion-proof indicator	
	Button	TL-EX-FH-0105 explosion-proof switch button	
	Control switch	Control switch	
	AC contactor	World famous brand	
	Thermal relay	World famous brand	
	PLC programmer	World famous brand	
	Soft starter	World famous brand	
<b>Rated voltage</b>		Low voltage:Maximum 1250V AC/DC, High voltage:Maximum 35kV/	
<b>Rated current</b>		Maximum 1500A	
<b>Frequency</b>		50Hz/60Hz	
<b>Degree of protection</b>		IP66	
<b>Ambient temperature</b>		-40°C~+40/60°C, -45°C~+40/60°C, -60°C~+40/60°C	
<b>Cable entry</b>		M□X1.5(default, exact size according to requirement) , NPT thread (optional)	
<b>Inlet direction</b>		Bottom in and bottom out	
<b>Installation method</b>		Wall type (default)	
		Stand type (optional)	

## TL-EX-FH-DP23-Series Explosion-proof Electrical Apparatus

### 5 Terminal Box Outline Proposal (Dimensions in mm)

The Maximum quantity of terminals that can be installed are show in the table below:

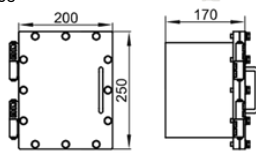
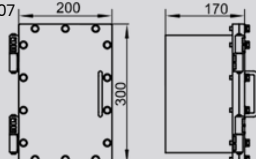
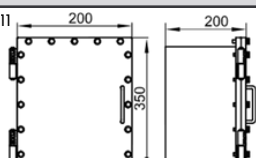
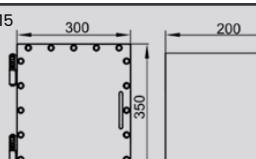
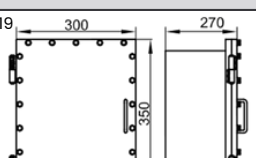
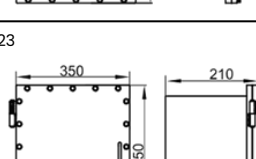
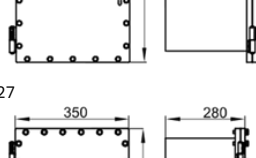
Box specifications	Guideway x Terminal (specification and quantity)											
	2.5 <sup>2</sup>	4 <sup>2</sup>	6 <sup>2</sup>	10 <sup>2</sup>	16 <sup>2</sup>	35 <sup>2</sup>	50 <sup>2</sup>	70 <sup>2</sup>	120 <sup>2</sup>	185 <sup>2</sup>	240 <sup>2</sup>	300 <sup>2</sup>
	UK3N	UK5N	UK6N	UK10N	UK16N	UK35	UKH50	UKH95	UKH150	UKH240	UKH240	--
	SAKDU25N	SAKDU4N	SAKDU6	SAKDU10	SAKDU16	SAKDU35	SAKDU50	SAKDU70	WFF120	WFF185	WFF300	WFF300
03 	1X20	1X18	1X15	1X12	1X9	--	--	--	--	--	--	--
07 	1X28	1X25	1X21	1X18	1X15	1X5	--	--	--	--	--	--
11 	1X36	1X32	1X28	1X24	1X20	1X5	--	--	--	--	--	--
15 	1X72	1X64	1X56	1X24	1X20	1X10	1X7	1X5	--	--	--	--
19 	2X72	2X64	2X56	2X24	2X20	2X10	2X7	2X5	--	--	--	--
23 	1X100	1X90	1X80	1X60	1X25	1X15	1X13	1X10	1X5	--	--	--
27 	2X100	2X90	2X80	2X60	2X25	2X15	2X13	2X10	2X5	--	--	--

## TL-EX-FH-DP23-Series Explosion-proof Electrical Apparatus

### 5 Control Station Outline Proposal (Dimensions in mm)

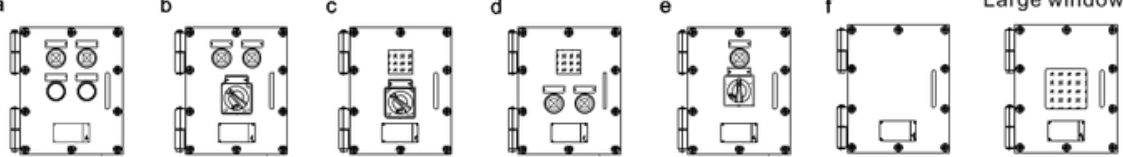
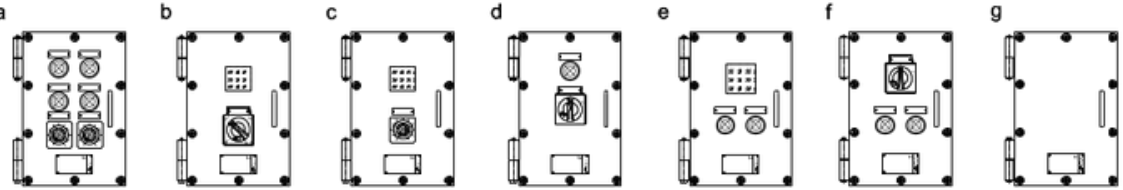
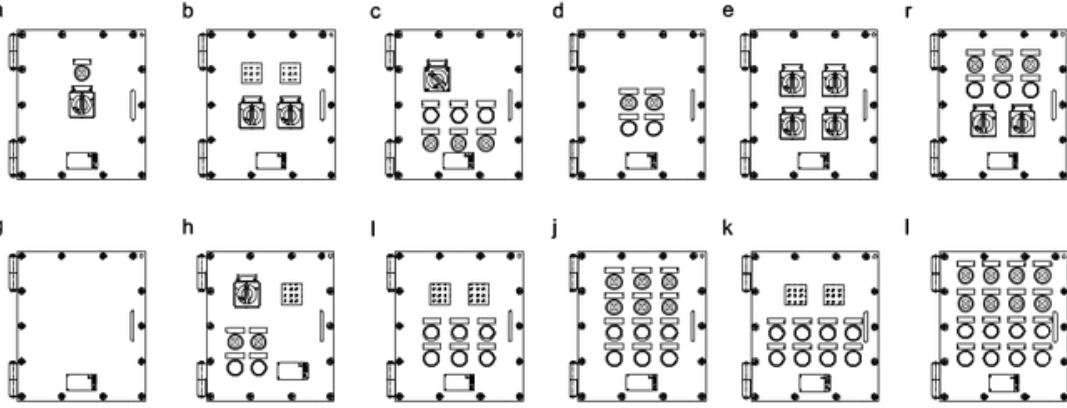
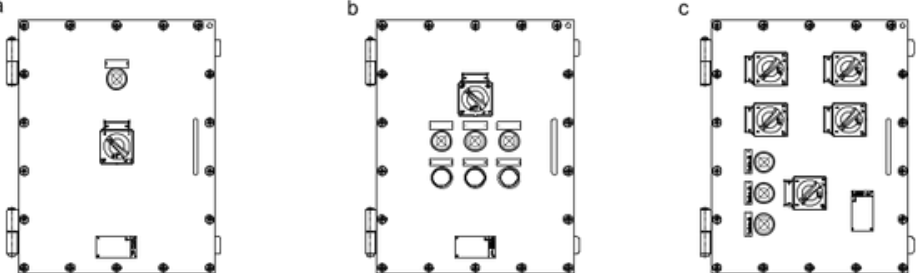
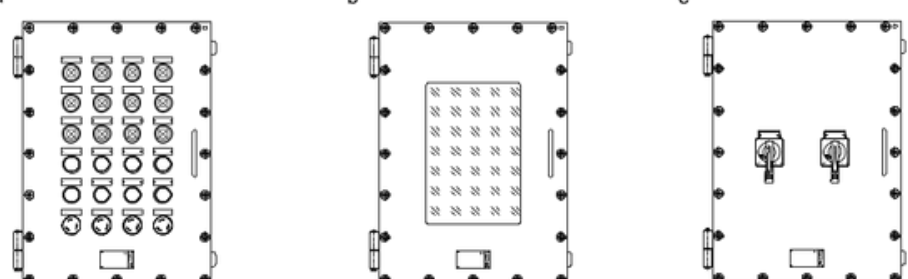
Enclosure code	Component layout
03	
07	
15/19	
23/27	
31/35	

## TL-EX-FH-DP23-Series Explosion-proof Electrical Apparatus

### 5 Control Station Outline Proposal (Dimensions in mm)

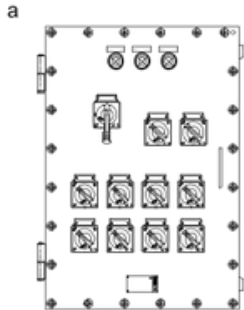
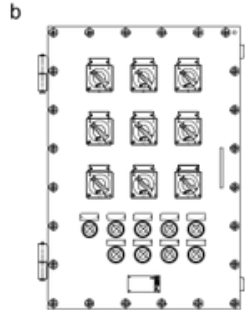
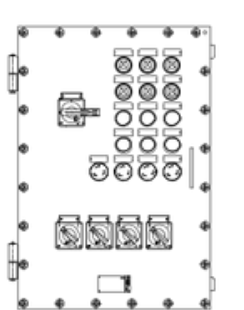
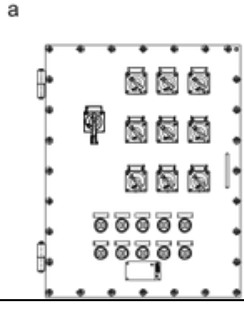
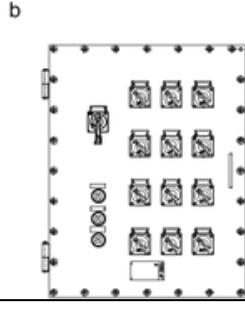
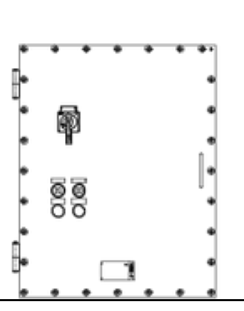
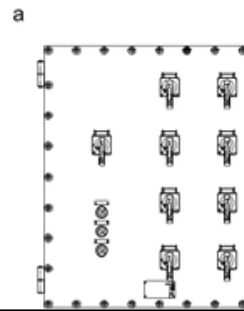
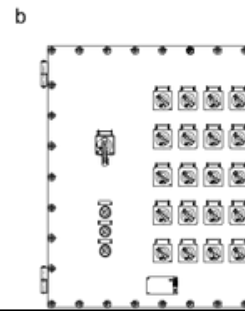
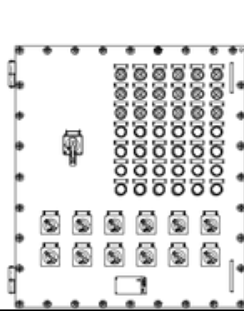
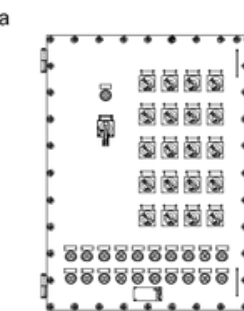
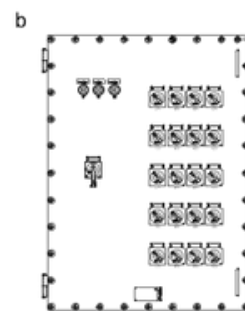
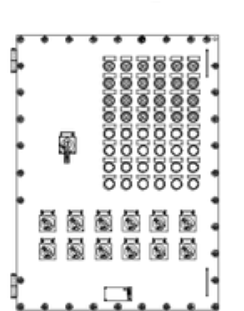
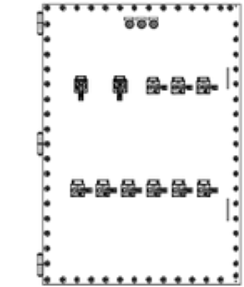
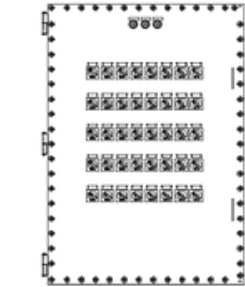
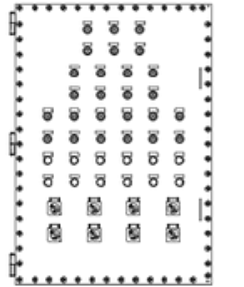
Enclosure code	Component layout		
39/43			
47/51			
53			
56/59			
63/66			

## TL-EX-FH-DP23-Series Explosion-proof Electrical Apparatus

### 6 Outline and Installation Dimension (Dimensions in mm)

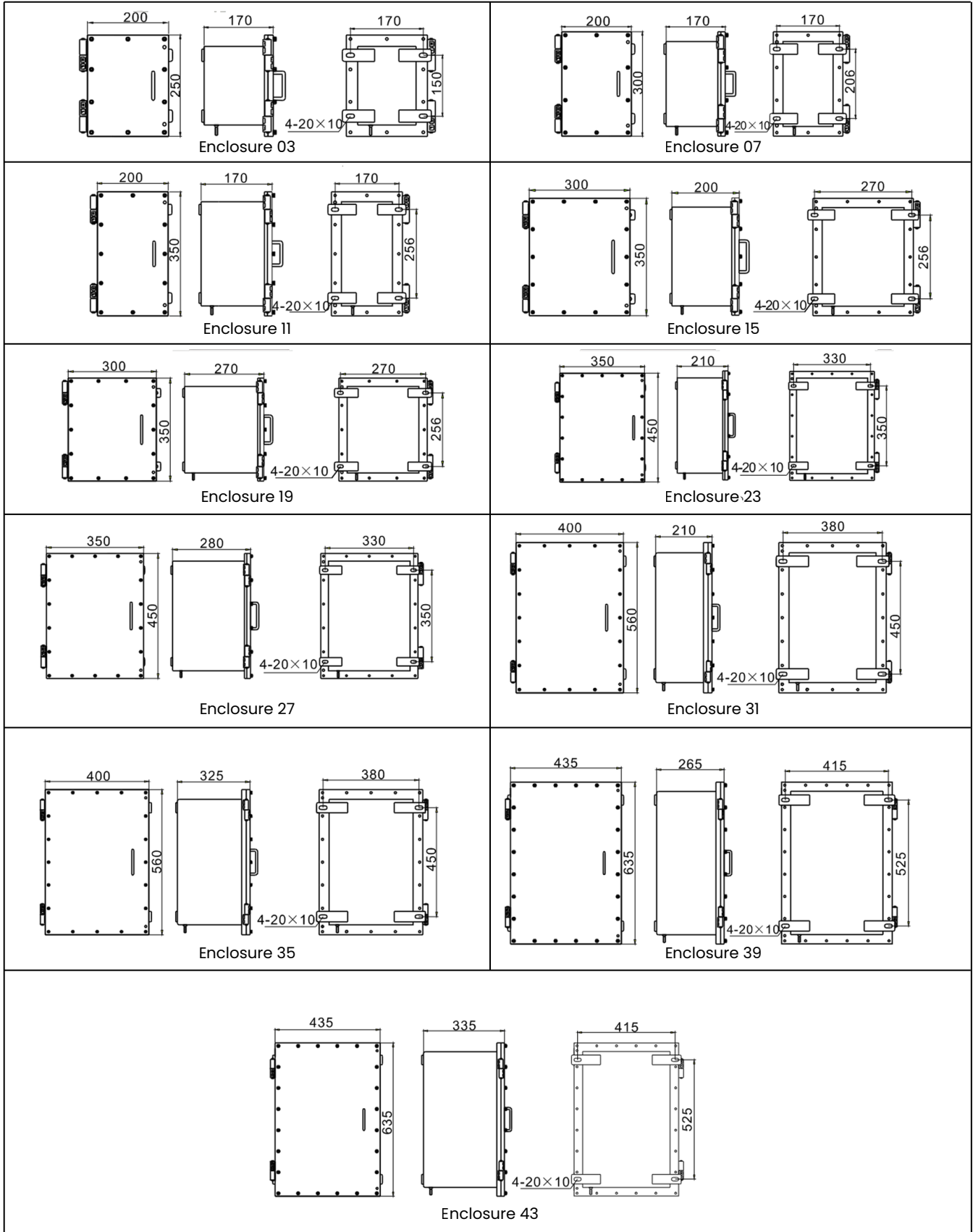

## TL-EX-FH-DP23-Series Explosion-proof Electrical Apparatus

### 6 Outline and Installation Dimension (Dimensions in mm)

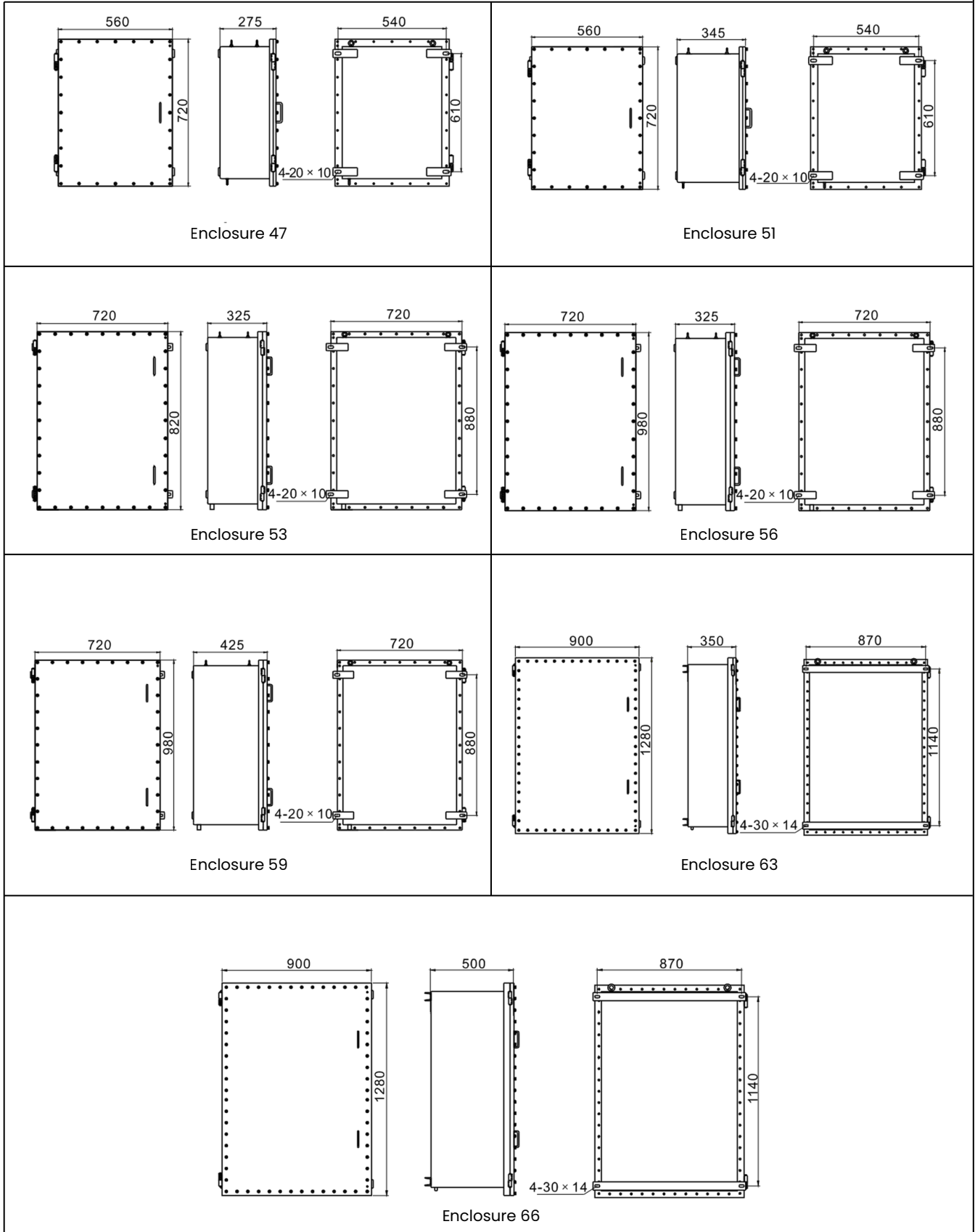

## TL-EX-FH-DP32-Series Explosion-proof Electrical Apparatus

### 1 Application and Features

- Explosion protection  
ATEX
- Application in hazardous area  
Zone 1 and Zone 2,  
Zone 21 and Zone 22
- Three types of explosion protection: Ex db IIC, Ex tb IIIC.
- The enclosure can be equipped with miniature circuit breakers (MCB) or molded case circuit breakers (MCCB), leakage circuit breakers, contactors, thermal relays, PLCs, control transformers, soft starters, control buttons, indicator lights, push switches, potentiometers, voltmeter, ammeter, tachometer, terminal block, etc.
- The circuit breakers using metal handle with fire-resistant and can be equipped with padlock.
- Can be customized according to user requirements, meet the certificate use restrictions;
- The number of elements and the maximum number of holes size need to meet the requirements of power dissipation and mechanical strength of the housing.
- Please specify the special requirements when ordering.



### 2 Nomenclature

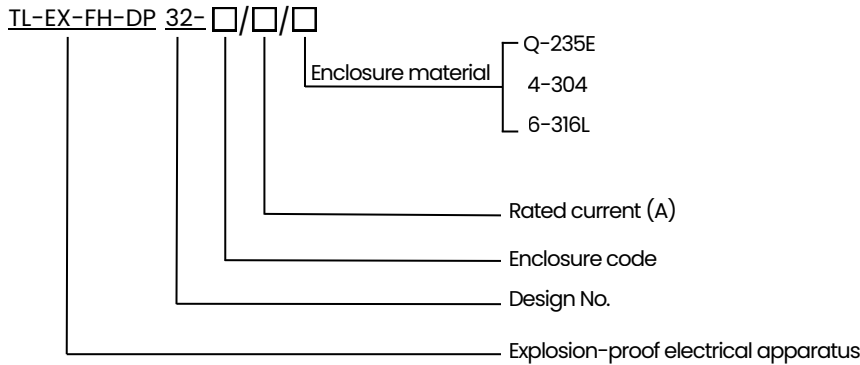

#### Note:

1. Please select the model according to the "Nomenclature" above, and specify all the technical parameters;
2. The electrical schematic diagram provided by user;
3. Please specify the number, specification and position of the cable entry holes, and cable entry device provided by user;
4. The rain shade is customizable by requirements.

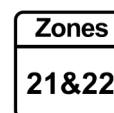
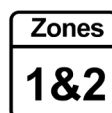
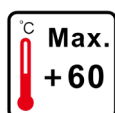
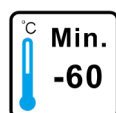

## TL-EX-FH-DP32-Series Explosion-proof Electrical Apparatus

### 4 Selection Table

Type	Enclosure size (mm)	Internal size (mm)	Maximum power consumption Ta:+40°C			Maximum power consumption Ta:+60°C		The weight of Empty enclosure
	L x W x H	L x W x H	T6/T80°C	T5/T95°C	T4/T130°C	T6/T80°C	T5/T95°C	
TL-EX-FH-DP32-03	220x220x150	212x212x134	80W	120W	200W	60W	100W	4.0 kg
TL-EX-FH-DP32-07	330x330x180	322x322x164	80W	120W	200W	60W	100W	7.5 kg
TL-EX-FH-DP32-11	400x400x200	388x388x182	100W	140W	240W	80W	120W	11.3 kg
TL-EX-FH-DP32-15	400x400x300	388x388x282	125W	170W	290W	100W	130W	22.5 kg
TL-EX-FH-DP32-19	400x420x200	388x408 x182	130W	200W	350W	110W	170W	25.3 kg
TL-EX-FH-DP32-23	400x420x300	388x408x282	140W	230W	420W	110W	200W	36.5 kg
TL-EX-FH-DP32-27	450x450x200	438x438x182	160W	280W	500W	120W	250W	/
TL-EX-FH-DP32-31	450x450x300	438x438x282	255W	360W	380W	110W	220W	105 kg
TL-EX-FH-DP32-35	550x550x300	530x530x278	200W	350W	620W	145W	320W	/
TL-EX-FH-DP32-39	550x550x350	530x530x328	410W	530W	660W	165W	360W	175 kg
TL-EX-FH-DP32-43	650x650x300	630x630x276	220W	380W	660W	190W	350W	/
TL-EX-FH-DP32-47	650x650x350	630x630x326	250W	400W	700W	200W	360W	/
TL-EX-FH-DP32-51	650x650x300	630x630x276	250W	400W	700W	200W	360W	/
TL-EX-FH-DP32-55	650x650x350	630x630x326	350W	500W	800W	300W	430W	251 kg
TL-EX-FH-DP32-56	650x650x400	630x630x376	460W	650W	750W	200W	380W	/

## TL-EX-FH-DP32-Series Explosion-proof Electrical Apparatus

### 3 Technical Parameter

<b>Ex marking</b>	<b>Gas</b>	⊕ II 2G Ex db IIC T6/T5/T4 Gb	Ex db IIC T6/T5/T4 Gb
		⊕ II 2G Ex db [ia Ga] IIC T6/T5/T4 Gb	Ex db [ia Ga] IIC T6/T5/T4 Gb
	<b>Dust</b>	⊕ II 2D Ex tb [ia Da] IIIC T80/T95/T130°C Db	Ex tb [ia Da] IIIC T80/T95/T130°C Db
<b>Conformity to standards</b>		IEC 60079-0, IEC 60079-1, IEC 60079-31 EN 60079-0, EN 60079-1, EN 60079-31	
<b>Enclosure material</b>	Enclosure	Aluminum alloy enclosure, powder coated, Industrial grey with dark lines texture (RAL7035)	
	Transparent part	Tempered glass, resistant to 4J impact	
	Rain shade	Bended steel plate surface powder coated, industrial grey with dark lines texture (RAL7035) or stainless steel 304/316L, please note when needed	
<b>Exposed fasteners</b>		Stainless steel	
<b>Components</b>	Power circuit breaker	Miniature circuit breaker (MCB) or molded case circuit breaker (MCCB) and leakage circuit breaker	
	Branch switch	Miniature circuit breaker (MCB) or molded case circuit breaker (MCCB) and leakage circuit breaker	
	Terminal block	World famous brand	
	Indicator	TL-EX-FH-0107 explosion-proof indicator	
	Button	TL-EX-FH-0105 explosion-proof pushbutton	
	Control switch	Control switch	
	AC contactor	World famous brand	
	Thermal relay	World famous brand	
	PLC programmer	World famous brand	
	Soft starter	World famous brand	
<b>Rated voltage</b>		Low voltage. Max. 1250V AC/DC, High voltage. Max. 15kVAC	
<b>Rated current</b>		Maximum 1000A	
<b>Frequency</b>		50Hz/60Hz	
<b>Degree of protection</b>		IP66,IP67	
<b>Ambient temperature</b>		-40°C / -60°C ~ +40°C / +60°C	
<b>Cable entry</b>		M□ x 1.5 (default, exact size according to requirement), NPT thread (optional)	
<b>Inlet direction</b>		Bottom in and bottom out (default)	
<b>Installation method</b>		Wall type (default)	
		Stand type (optional)	

## TL-EX-FH-DP32-Series Explosion-proof Electrical Apparatus

### 4 Selection table of Electrical Apparatus

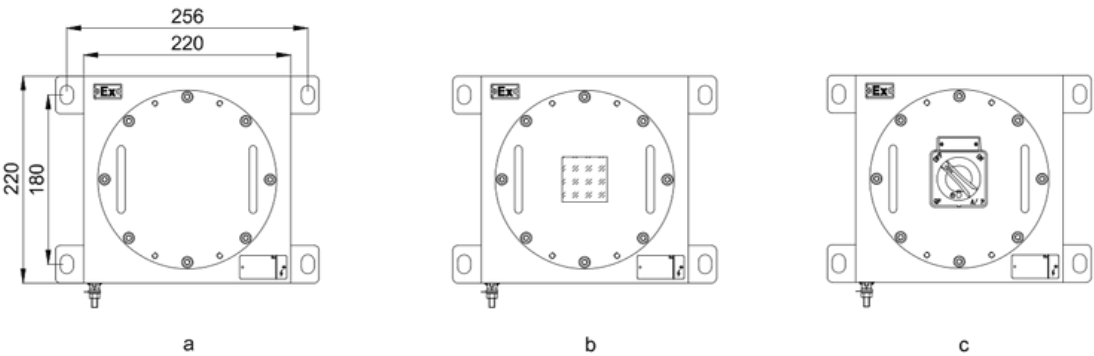
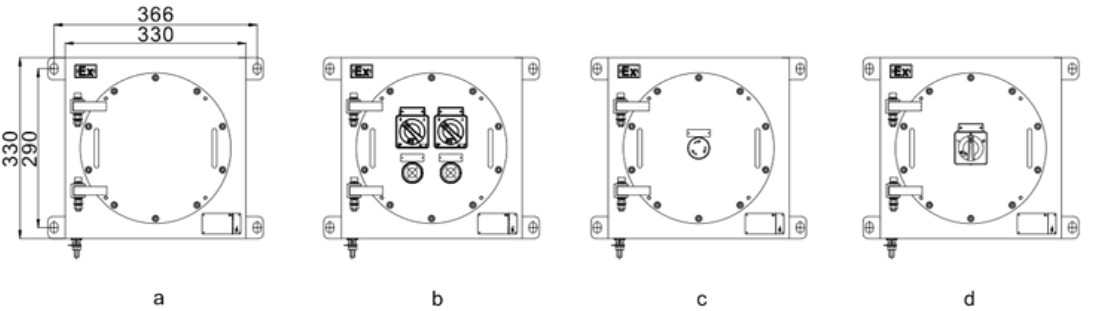
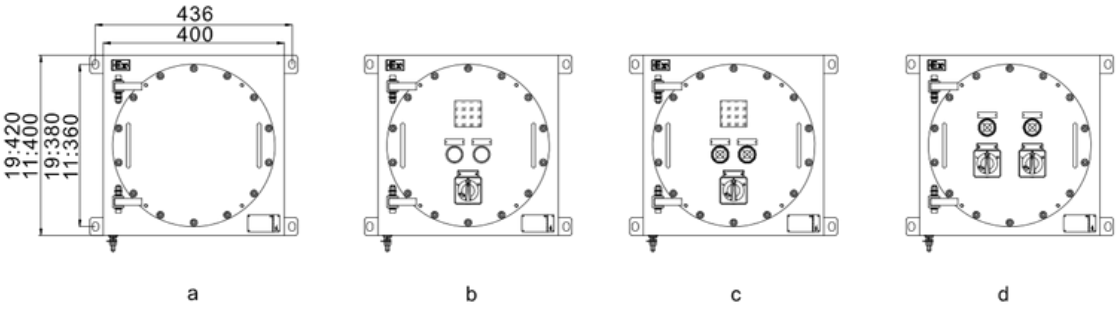
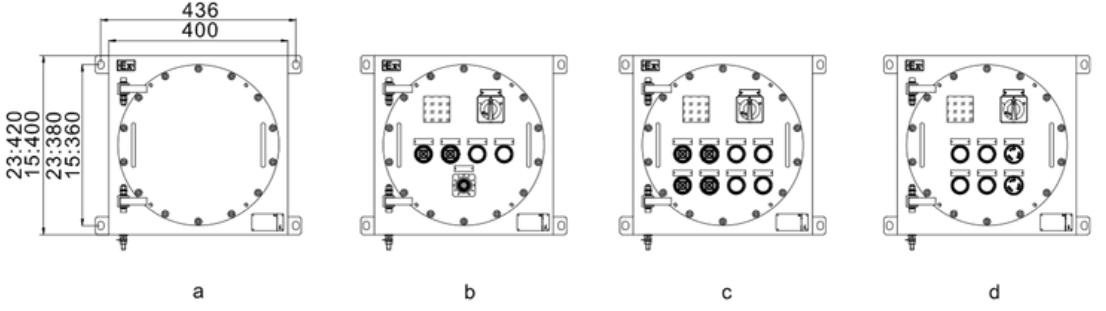
Enclosure code	Component layout
03	 <p>Diagram showing three component layouts (a, b, c) for enclosure code 03. Dimensions: 256, 220, 220, 180.</p>
07	 <p>Diagram showing four component layouts (a, b, c, d) for enclosure code 07. Dimensions: 366, 330, 290.</p>
11/19	 <p>Diagram showing four component layouts (a, b, c, d) for enclosure code 11/19. Dimensions: 436, 400, 19:420, 11:400, 19:380, 11:360.</p>
15/23	 <p>Diagram showing four component layouts (a, b, c, d) for enclosure code 15/23. Dimensions: 436, 400, 23:420, 15:400, 23:380, 15:360.</p>

## TL-EX-FH-DP32-Series Explosion-proof Electrical Apparatus

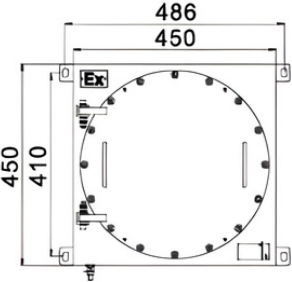
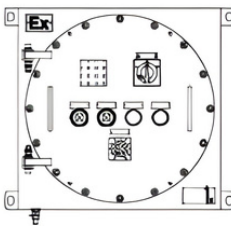
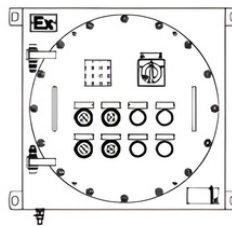
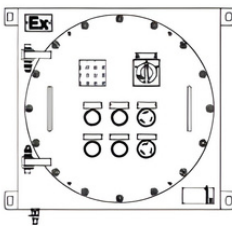
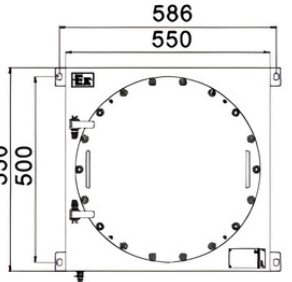
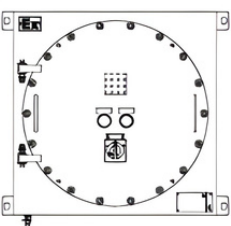
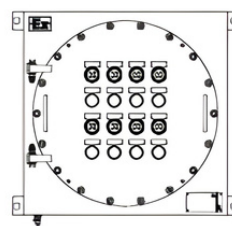
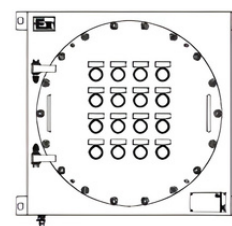
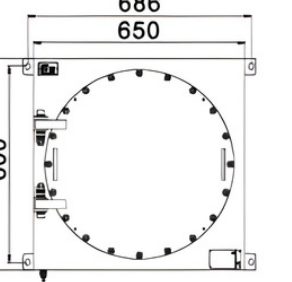
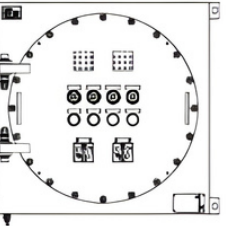
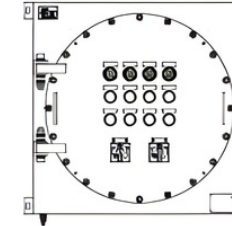
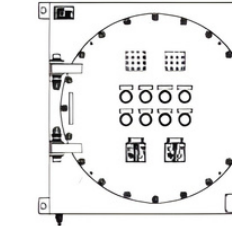
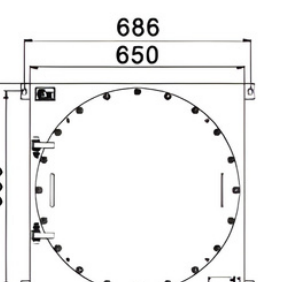
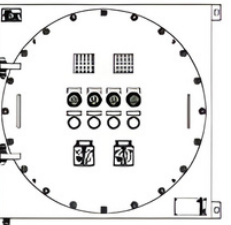
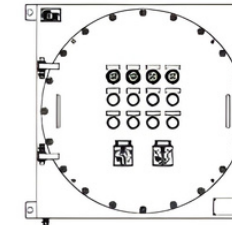
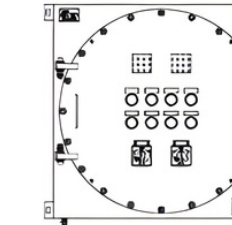
Enclosure code	Component layout			
27/31	 <p>a</p>	 <p>b</p>	 <p>c</p>	 <p>d</p>
35/39	 <p>a</p>	 <p>b</p>	 <p>c</p>	 <p>d</p>
43/47	 <p>a</p>	 <p>b</p>	 <p>c</p>	 <p>d</p>
51/55	 <p>a</p>	 <p>b</p>	 <p>c</p>	 <p>d</p>

## TL-EX-FH-DP50-Series Explosion-proof Electrical Apparatus

### 1 Application and Features

- Explosion protection  
ATEX
- Application in hazardous area  
Zone 1 and Zone 2,  
Zone 21 and Zone 22
- Increased safety type enclosure, the branch switch and main switch are operated by the operation handle on the panel.
- Glass fiber reinforced unsaturated polyester resin (GRP) enclosure.
- The wires inside the panel are connected to terminals when delivery.
- Stainless steel exposed fasteners, anti-drop structure, easy installation and maintenance
- The padlock is optional for MCB operating handle.
- Cable entries are sealed with stopping plug, the cable glands shall be supplied by users
- Please specify the special requirements when ordering.



### 2 Nomenclature

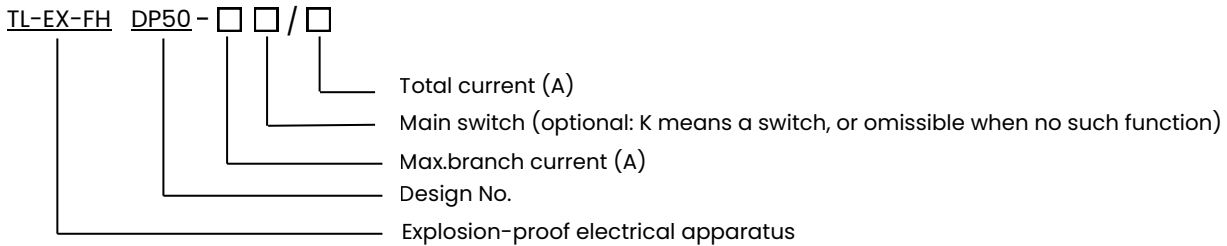

#### Note:

1. Please select the model according to the catalog, and specify all the technical parameters;
2. Please provide the electrical schematic diagram;
3. Please specify the number, specification and position of the cable entry holes, and ex-proof cable glands provided by user.

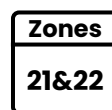
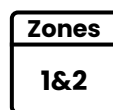
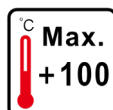
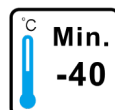

## TL-EX-FH-DP50-Series Explosion-proof Electrical Apparatus

### 3 Technical Parameter

<b>Ex marking</b>	<b>Gas</b>	Ex db eb IIC T6...T4 Gb							
	<b>Dust</b>	Ex tb IIIC T80°C Db							
<b>Conformity to standards</b>		IEC 60079-0, IEC 60079-1, IEC 60079-7, IEC 60079-31							
<b>Enclosure Material</b>	<b>Rain shade</b>	GRP (Polyester resin, glass fibre reinforced)							
		Bended steel plate surface powder coated (black color) or stainless steel 304/316, please note when needed							
<b>Exposed fastener</b>		Stainless steel, anti-drop structure							
<b>Built-in component</b>	Exlosion-proof circuitbreaker								
	Explosion-proof residual current circuit breaker								
	Explosion-proof motor protection switch								
	Explosion-proof surge protector								
	Explosion-proof switch module								
		International famous brand							
<b>Rated voltage</b>	AC	690, 500, 480, 415, 400, 380, 240, 230, 220, 127, 110, 48, 36, 24, 12V AC							
	DC	230, 220, 127, 110, 48, 36, 24, 12V AC							
<b>Rated current</b>	Main switch	25A≤Ie≤250A							
	Branch switch	1A≤Ie≤63A							
<b>Frequency</b>		50Hz/60Hz							
<b>Ambient temperature</b>		-40°C~+40°C, -40°C~+45°C, -40°C~+60°C							
<b>Degree of protection</b>		IP66							
<b>Cable entries</b>	Stand ard	G1/2 - G2							
	Optional	M16X1.5 - M75X1.5 is recommended							
<b>Inlet direction</b>		Bottom in and bottom out, upon request							
<b>Installation Method</b>	Hanging type (standard)								
	Floor type (optional)								
<b>Parameter</b>		<b>Main circuit current</b>	<b>Branch current</b>	<b>Main circuit current</b>	<b>Branch current</b>	<b>Main circuit current</b>	<b>Branch current</b>	<b>Main circuit current</b>	<b>Branch current</b>
		Ie≤250A	Ie≤63A	Ie≤80A	Ie≤63A	Ie≤63A	Ie≤50A	Ie≤32A	Ie≤16A
	Gas temperature class	T4/T5		T4/T5		T4/T5		T4/T5/T6	
Dust temperature class	T80°C		T80°C		T80°C		T80°C		

## TL-EX-FH-DP50-Series Explosion-proof Illumination (Power) Distribution Box

### 4 Technical Parameter Of Built-in Component

Explosion-proof component	Explosion-proof residual current circuit breaker	Explosion-proof motor protection switch	Explosion-proof surge protector	Explosion-proof switch module
<b>Type</b>	8051-(L)	8054	8057	HL0155
<b>Rated working voltage</b>	220-250V 380-415V	220-250V 380-415V	220-250V 380-415V	220-250V 380-690V
<b>Rated current (A)</b>	1, 2, 4, 6, 10, 16, 20, 25, 32, 40, 50, 63	0.1-0.16, 0.16-0.25, 0.25-0.4, 0.4-0.63, 0.63-1,1-1.6,1.6-2.5, 2.5-4,4-6.3,6.3-10,10-16, 16-20,20-25	Maximum discharge current 10, 20, 40, 65, 80, 120kA	16(25), 32(40), 63(80), 125(180)

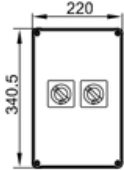
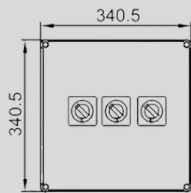
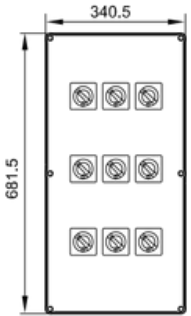
Outline	Built-in Component					
	Size	Specification	Quantity	Size	Specification	Quantity
	Size 1 Size 2 Size 3 Size 4 Size 4	8051-1P 8051-2 P 8051-3 P 8051-4 P 8051-L2 P	2 pcs 2 pcs 1 pcs 1 pcs 1 pcs	Size 6	8054	1 pcs 1 pcs 1 pcs
	Size 1 Size2 Size3 Size4 Size4 Size5	8051-1P 8051-2P 8051-3P 8051-4P 8051-L2P 8051-L3P(4P)	4 pcs 4 pcs 3 pcs 2 pcs 2 pcs 1 pcs	Size 6	8054	3 pcs 2 pcs 1 pcs
	Size 1 Size2 Size3 Size4 Size4 Size5	8051-1P 8051-2 P 8051-3 P 8051-4 P 8051 L2P 8051-L3 P(4P)	4 pcs x 2-3 rows 4 pcs x 2-3rows 3 pcs x 2-3rows 2 pcs x 2-3rows 2 pcs x 2-3 rows 1 pcs x 2-3rows	Size 6	8054	3 pcs x 2-3rows 2 pcs x 2 rows 1 pcs x 2 rows

Note: The specific drawing can be designed upon request.

## TL-EX-FH-DP50-Series Explosion-proof Illumination (Power) Distribution Box

### 6 Outline and Installation Dimension (Proposal) (Dimensions in mm)

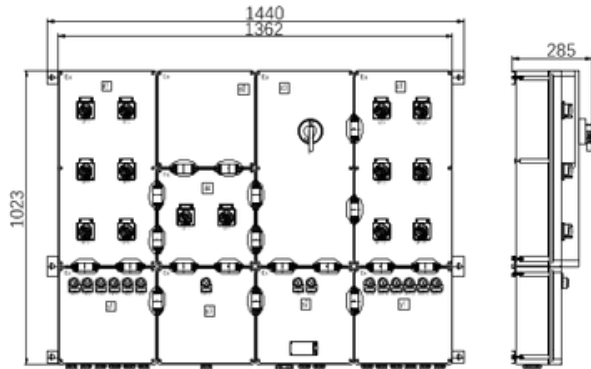

TL-EX-FH-DP50-63K/250 Explosion-proof electrical apparatus

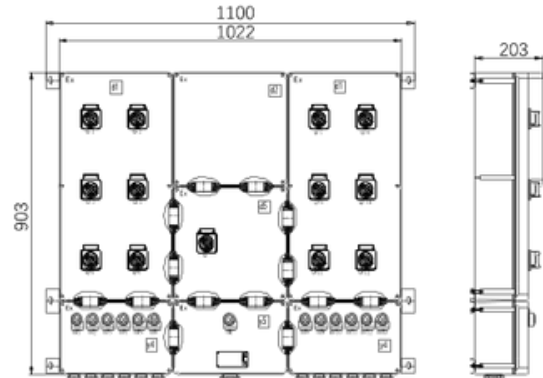

TL-EX-FH-DP50-16K/80 Explosion-proof electrical apparatus

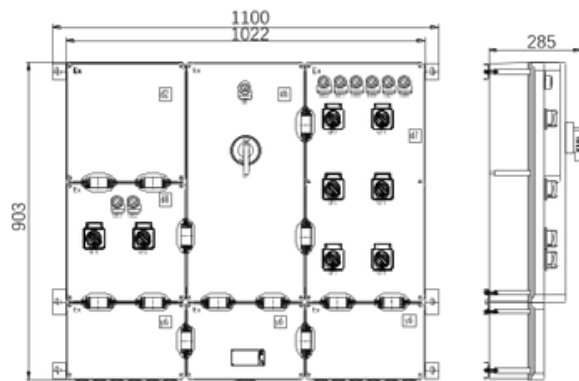

TL-EX-FH-DP50-16K/32 Explosion-proof electrical apparatus

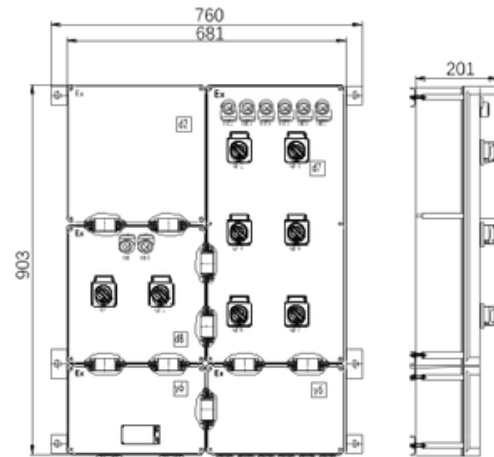

TL-EX-FH-DP50-16K/25 Explosion-proof electrical apparatus

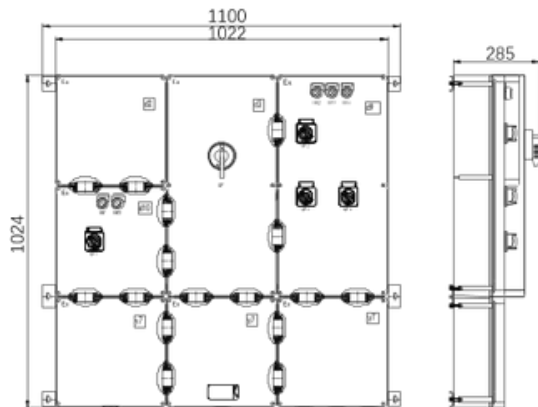

TL-EX-FH-DP50-63K/125 Explosion-proof electrical apparatus

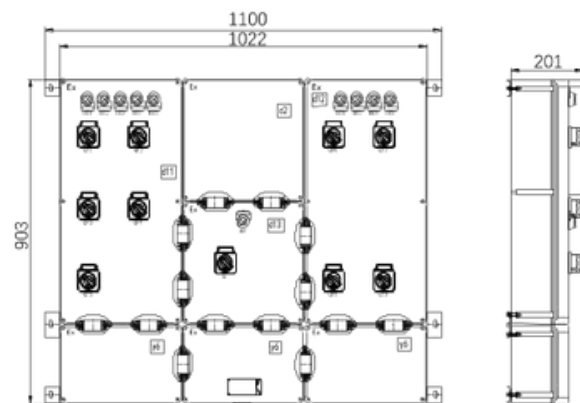

TL-EX-FH-DP50-16K/32 Explosion-proof electrical apparatus

Note: The specific drawing can be designed upon request.

## TL-EX-FH-BH02-Series Explosion-proof Electrical Apparatus (Terminal Box)

### 1 Application and Features

- Explosion protection ATEX
- Application in hazardous area Zone 0, Zone 1 and Zone 2, Zone 21 and Zone 22
- Stainless steel enclosure, three types of explosion protection (Ex eb, Ex ia, Ex tb IIC), which can meet the requirements of various places.
- There are 19 types of enclosure specifications, the current, the number of terminals, the size <y and direction of the entry can be customized upon request.
- Stainless steel exposed fastener, anti dropping structure, easy installation and maintenance.



### 2 Nomenclature

TL-EX-FH- BH02-□ / □ / □ D □ / □ L □ / □ X □ / □ R □ / □ □

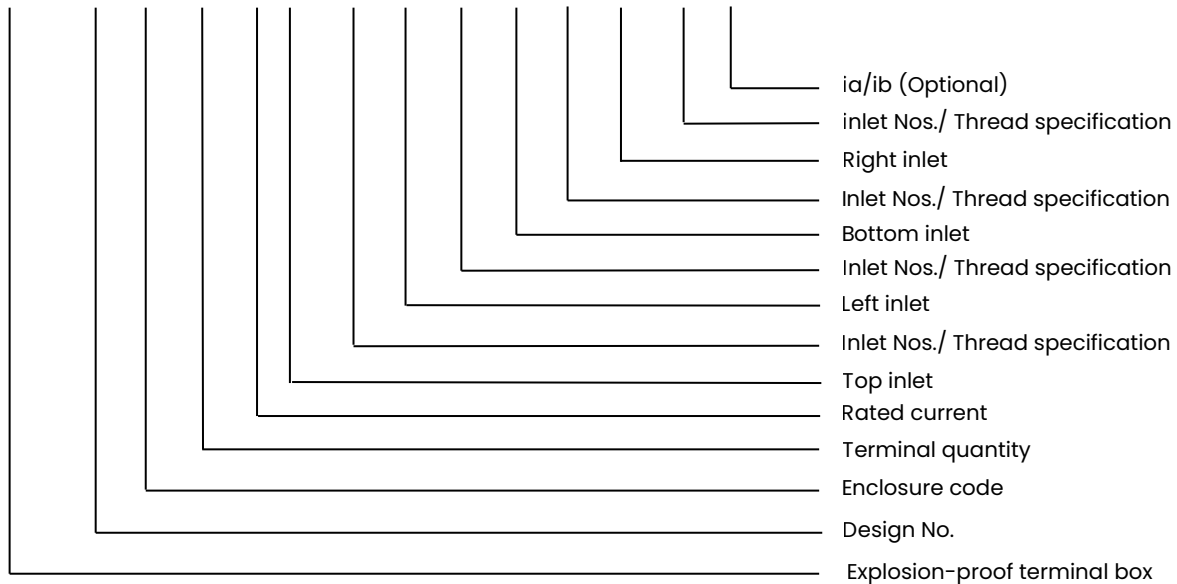



### 3 Technical Parameter

Ex marking	Gas	⊕ II 2G Ex eb IIC T6/T5/T4 Gb	Ex eb IIC T6/T5/T4 Gb							
		⊕ II G Ex ia IIC T6 Ga	Ex ia IIC T6 Ga							
		⊕ II G Ex ia IIC T6 Gb	Ex ia IIC T6 Gb							
	Dust	⊕ II 2 Ex tb IIC T80/T95/T130°CDb	Ex tb IIC T80/T95/T130°CDb							
Conformity to standards		IEC 60079-0, IEC 60079-7, IEC 60079-11, IEC 60079-31 EN 60079-0, EN60079-7, EN60079-11, EN60079-31								
Enclosure material		Stainless steel								
Brand of terminal		International brand								
Exposed fastener		Stainless steel								
Rated voltage	Ex e, Ex tb	Max. 690V AC, 250V DC								
	Ex i, Ex tb	Max. AC/DC36V								
Rated voltage		1.5mm <sup>2</sup>	2.5mm <sup>2</sup>	4mm <sup>2</sup>	6mm <sup>2</sup>	10mm <sup>2</sup>	16mm <sup>2</sup>	35mm <sup>2</sup>	50mm <sup>2</sup>	
	Ex e, Ex tb	—	10A	16A	25A	40A	50A	100A	142A	
	Ex i, Ex tb	5A	—	—	—	—	—	—	—	
Degree of protection		IP66								
Ambient temperature	Ex e, Ex tb	-40°C~+40/55°C								
	Ex i, Ex tb	-40°C~+40/45/55/60°C								

## TL-EX-FH-BH02-Series Explosion-proof Terminal Box

### 4 Selection Table

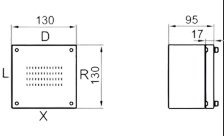
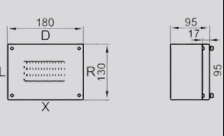
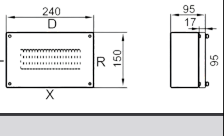
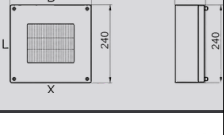
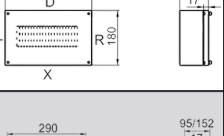
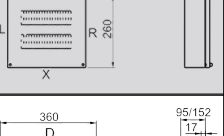
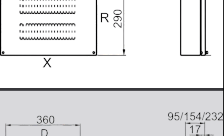
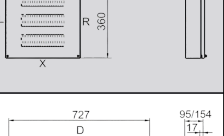
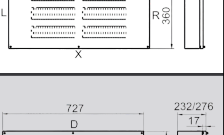
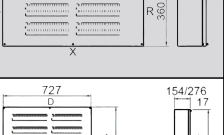
Maximum quantity of terminals that can be installed are show in the table below:

Enclosure specifications	Guideway x Terminal (specification and quantity)						outlet direction	Available maximum cable entries quantity							Weight (kg)
	2.5 <sup>2</sup>	4 <sup>2</sup>	6 <sup>2</sup>	10 <sup>2</sup>	16 <sup>2</sup>	35 <sup>2</sup>		M16	M20	M25	M32	M40	M50	M63	
	UK3N SAK2.5EN	UK5N SAK4EN	UK6N SAK6EN	UK10N SAK10EN	UK16N SAK16EN	UK35N SAK35EN									
	1X14	1X12	1X9	--	--	--	D/X	8	6	5	3	2	1	--	1.3
							L/R	8	6	5	3	2	1	--	
	1X21	1X18	1X13	1X11	1X8	--	D/X	12	10	8	4	3	2	--	1.9
							L/R	8	6	5	3	2	1	--	
	1X27	1X23	1X18	1X14	1X12	1x9	D/X	16	12	10	4	3	3	--	3.1
							L/R	10	8	8	3	2	2	--	
	2X27	2X23	1X18	1X14	1X12	1x9	D/X	16	12	10	4	3	3	--	4.0
							L/R	16	12	10	4	3	3	--	
	1X37	1X31	1X25	1X20	1X18	1x11	D/X	18/36	16/21	14/21	5/10	4/8	4/6	--/4	4.5 /5.5
							L/R	12/24	10/15	8/12	3/6	3/4	2/3	--/2	
	2X37	2X31	1X25	1X20	1X18	1x11	D/X	18/36	16/21	14/21	5/10	4/8	4/6	--/4	6.5 /5.5
							L/R	16/32	14/21	12/18	5/10	4/6	3/5	--/3	
	2X52	2X43	1X33	1X25	1X22	1x18	D/X	24/48	20/30	18/27	7/14	5/10	4/8	--/5	8.5 /9.5
							L/R	18/36	16/21	14/21	5/10	4/8	4/6	--/4	
	3X52	3X43	2X33	2X25	2X22	1x18	D/X	24/48 /66	20/30 /50	18/27 /35	7/14 /28	5/10 /15	4/8 /12	--/5/8	10.08 /11.8 /12.8
							L/R	24/48 /66	20/30 /50	18/27 /35	7/14 /28	5/10 /15	4/8 /12	--/5/8	
	6X52	6X43	2X66	2X50	2X44	1x36	D/X	48/92	40/60	36/54	14/28	10/20	8/10	--/8	17.5 /18.5
							L/R	24/48	20/30	18/27	7/14	5/10	4/8	--/5	
	6X52	6X43	2X66	2X50	2X44	1x36	D/X	138 /161	100 /120	83 /102	42/56	30/40	20/25	15/20	21/22
							L/R	66/77	50/60	27/54	28/30	15/20	12/16	8/10	
	12X52	12X43	12X66	4X50	4X44	3X36	D/X	92 /161	60 /120	54 /102	28/56	20/40	10/25	8/20	29/31
							L/R	92 /161	60 /120	54 /102	28/56	20/40	10/25	8/20	

## TL-EX-FH-BH02-Series Explosion-proof Terminal Box

### 5 Outline and Installation Dimension (Dimensions in mm)

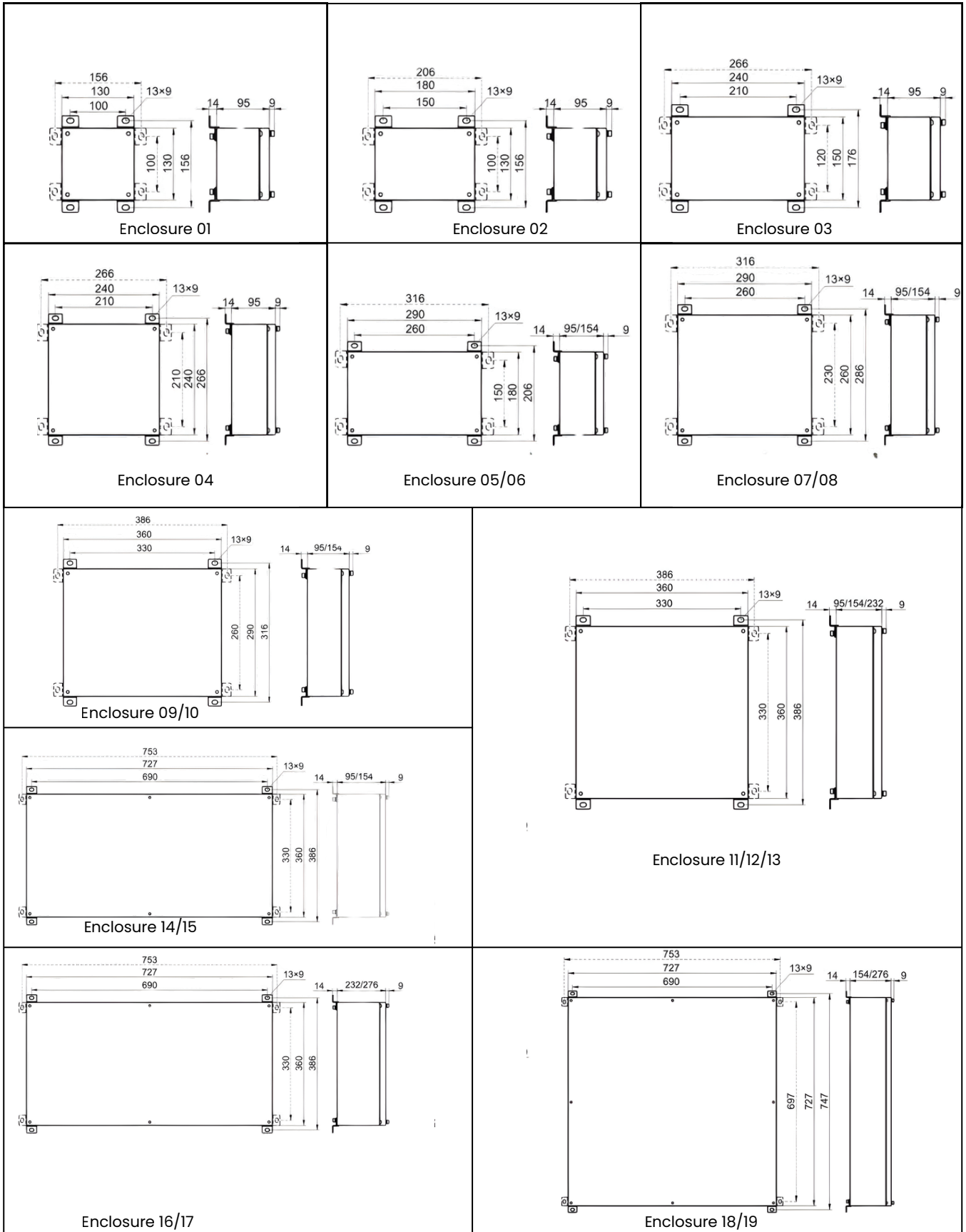

## TL-EX-FH-BH03-Series Explosion-proof Terminal Box

### 1 Application and Features

- Explosion protection ATEX
- Application in hazardous area Zone 0, Zone 1 and Zone 2, Zone 21 and Zone 22
- This series of products has 4 types of explosion protection (Ex eb, Ex ia, Ex ib, Ex tb IIC), which can meet various requirements.
- GRP enclosure.
- There are 7 types of enclosures; easy to customize current, terminals, size and direction of entry according to customer requirements.
- Stainless steel exposed fastener, anti-dropping structure – easy installation and maintenance.

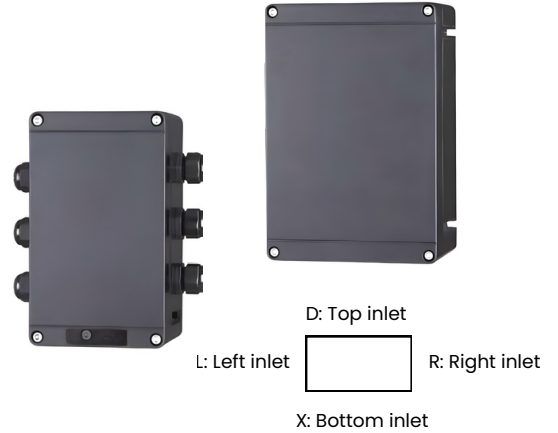

### 2 Nomenclature

TL-EX-FH- BH03 - □□ / □ / □ □ □ / □ L □ / □ X □ / □ R □ □ □

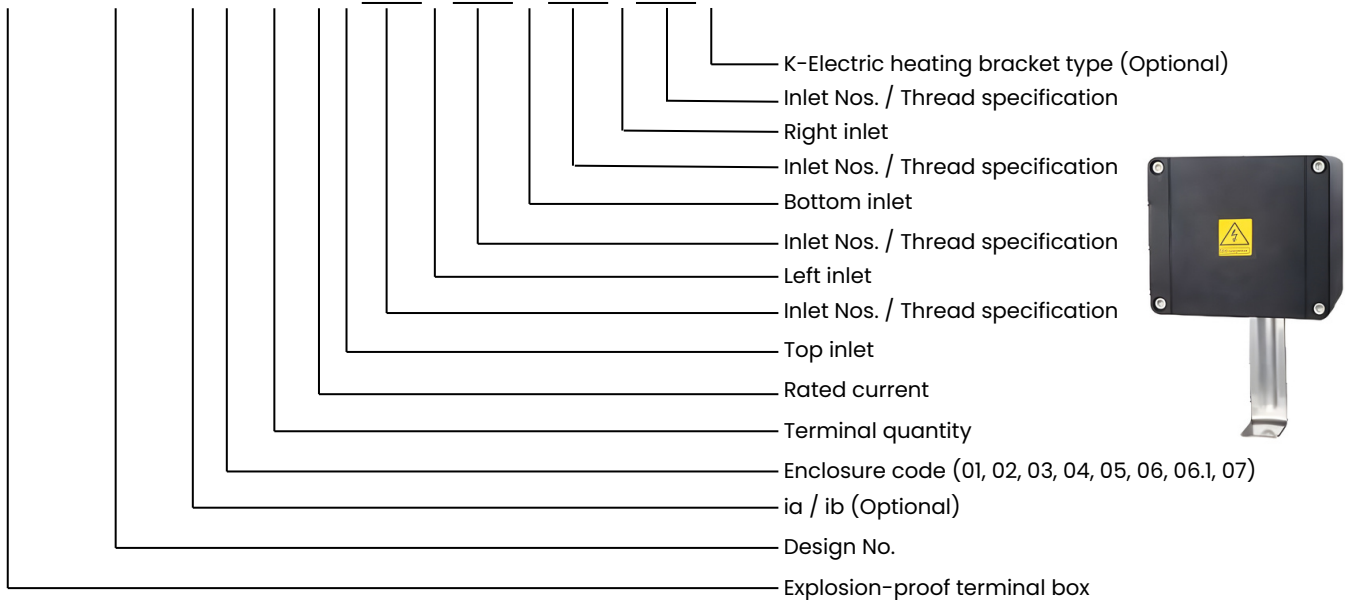

### 3 Technical Parameter

Ex marking	Gas	⊕ II 2G Ex eb IIC T6/T5 Gb	Ex eb IIC T6/T5 Gb						
		⊕ II G Ex ia IIC T6 Ga	Ex ia IIC T6 Ga						
		⊕ II 2G Ex ib IIC T6 Gb	Ex ib IIC T6 Gb						
	Dust	⊕ II 2D Ex tb IIC T80/T95°C Db	Ex tb IIC T80/T95°C Db						
Conformity to standards		IEC 60079-0, IEC 60079-1, IEC 60079-7, IEC 60079-31 EN 60079-0, EN60079-1, EN60079-7, EN60079-31							
Enclosure material		GRP (Polyester resin, glass fibre reinforced), anti-static							
Enclosure color		Black							
Brand of terminal		International brand							
Exposed fastener		Stainless steel							
Degree of protection		IP66							
Rated voltage	Ex e, Ex tb	Max 690V AC, 220V DC							
	Ex i, Ex tb	Max AC/DC 36V							
Rated current		1.5mm <sup>2</sup>	2.5mm <sup>2</sup>	4mm <sup>2</sup>	6mm <sup>2</sup>	10mm <sup>2</sup>	16mm <sup>2</sup>	35mm <sup>2</sup>	50mm <sup>2</sup>
	Ex e, Ex tb	-	10A	16A	25A	40A	50A	100A	142A
	Ex i, Ex tb	5A	-	-	-	-	-	-	-
Ambient temperature	Ex e, Ex tb	-40°C ~ +40/55°C							
	Ex i, Ex tb	-40°C ~ +50/60/65°C							

## TL-EX-FH-BH03-Series Explosion-proof Terminal Box

### 4 Selection Table (Dimension in mm)

The maximum terminal cross-section is 35mm, and the maximum quantity of terminals that can be installed are shown in the table below.

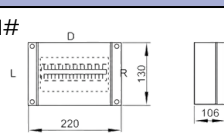
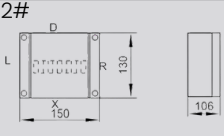
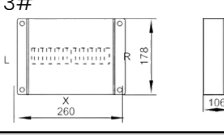
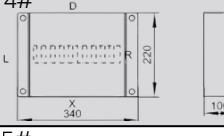
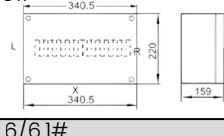
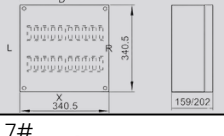
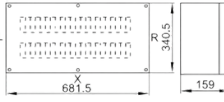
Enclosure specifications	Guideway Terminal (specification and quantity)								Outlet direction	Cable gland quantity								Weight (kg)
	1.5 <sup>2</sup>	2.5 <sup>2</sup>	4 <sup>2</sup>	6 <sup>2</sup>	10 <sup>2</sup>	16 <sup>2</sup>	35 <sup>2</sup>	50 <sup>2</sup>		M16	M20	M25	M32	M40	M50	M63	--	
	UK2N	UK3N	UK5N	UK6N	UK10N	UK16N	UK35N	UK50N		G15	G20	G25	G32	G40	G50	G70	--	
	SAK15EN	SAK25EN	SAK4EN	SAK6EN	SAK10EN	SAK16EN	SAK35EN	SAK50EN										
<b>1#</b> 	1x12	1x12	1x10	1x8	--	--	--	--	D/X	3	3	2	1	1	--	--	1.2	
									L/R	--	2	2	1	1	1	--		
<b>2#</b> 	1x25	x25	1x20	1x15	--	--	--	--	D/X	7	5	3	3	2	1	--	1.5	
									L/R	--	4	3	3	2	1	--		
<b>3#</b> 	1x30	1x30	1x27	1x20	1x15	1x13	--	--	D/X	8	6	4	3	2	--	--	2.3	
									L/R	--	5	4	3	3	2	--		
<b>4#</b> 	1x49	1x49	1x41	1x31	1x24	1x20	--	--	D/X	12	10	8	4	3	3	--	3.3	
	2x39	2x40	2x31	2x18	--	--	--	--	L/R	--	8	7	4	3	3	--		
<b>5#</b> 	1x49	1x49	1x41	1x31	1x24	1x20	1x10	--	D/X	20	14	12	7	5	3	3	4.3	
	2x40	2x40	2x31	2x18	--	--	--	--	L/R	--	12	9	7	4	3	2		
<b>6/6.1#</b> 	1x102	1x51	1x43	1x32	1x26	1x21	1x17	1x8	D/X	20	14	12	7	5	3	3	6.1 / 6.7	
	2x73	2x49	2x41	2x31	2x24	2x20	--	--	L/R	--	12	9	7	4	3	2		
<b>7#</b> 	1x102	1x102	1x86	1x64	1x52	1x42	1x34	1x16	D/X	32	22	18	12	6	4	4	1.3	
	2x102	2x98	2x82	2x62	2x48	2x40	--	--	L/R	--	18	12	12	6	6	4		

### 5 Outline and Installation Dimension (Dimensions in mm)

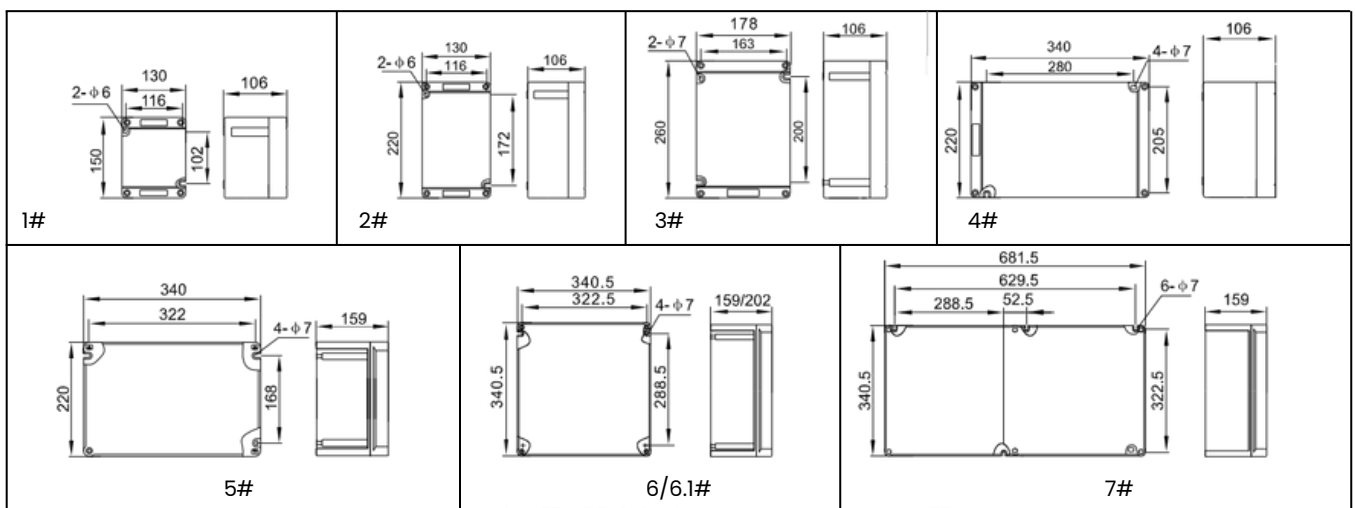

## TL-EX-FH-BH05-Series Explosion-proof Terminal Box

### 1 Application and Features

- Explosion protection ATEX
- Application in hazardous area Zone 0, Zone 1 and Zone 2, Zone 21 and Zone 22
- This series of products has 4 types of explosion protection (Ex eb, Ex ia, Ex ib, Ex tb IIIC) which can meet the requirements of various applications. PA66 enclosure.
- There are two types of enclosures in which current, terminal, size, and direction of entry can be customized based on customer requirements.
- Type A: open crimping type terminal in enclosure.
- Type B (Standard): an international brand of terminal installed in the enclosure.
- Stainless steel exposed fastener, anti-dropping structure, easy installation and maintenance.

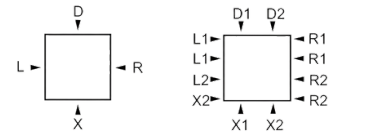

TL-EX-FH-BH05-01 TL-EX-FH-BH05-02

### 2 Nomenclature

TL-EX-FH- BH05-□/□□/□/□D□/□L□/□X□/□R□/□

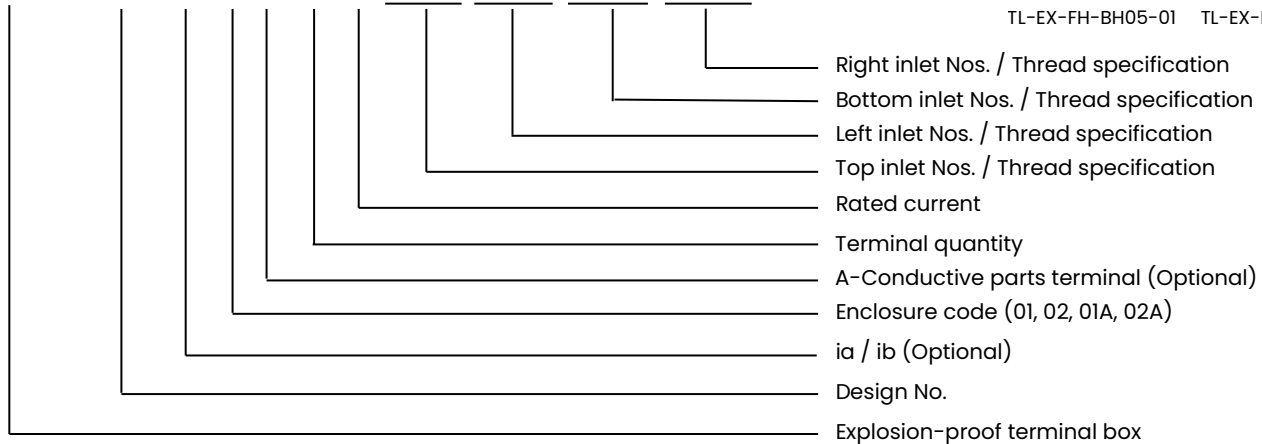

**Note:** Please confirm the quantity, specification, and direction (position) of cable entry holes if needed. No cable gland is provided by default at delivery; it must be supplied by users.

### 3 Technical Parameter

<b>Ex marking</b>	<b>Gas</b>	II 2G Ex eb IIC T6 Gb	Ex eb IIC T6 Gb
		II 1G Ex ia IIC T6 Ga	Ex ia IIC T6 Ga
		II 2G Ex ib IIC T6 Gb	Ex ib IIC T6 Gb
	<b>Dust</b>	II 2D Ex tb IIIC T80°C Db	Ex tb IIIC T80°C Db
<b>Conformity to standards</b>		IEC 60079-0, IEC 60079-1, IEC 60079-7, IEC 60079-31 EN 60079-0, EN60079-1, EN60079-7, EN60079-31	
<b>Enclosure material</b>		Nylon (PA66)	
<b>Enclosure color</b>		Black	
<b>Brand of terminal</b>		Type A: open crimping type terminal in enclosure / Type B (Standard): international brand	
<b>Exposed fastener</b>		Stainless steel	
<b>Degree of protection</b>		IP66	
<b>Cable gland</b>		M20×1.5, M25×1.5, M32×1.5 (Cable gland is not matched as standard, please specify if necessary.)	
<b>Rated voltage</b>	<b>Ex e, Ex tb</b>	Max 690V AC, 220V DC	
	<b>Ex i, Ex tb</b>	Max AC/DC 36V	
<b>Rated current</b>	<b>Wire diameter</b>	1.5mm <sup>2</sup>	2.5mm <sup>2</sup>
	<b>Ex e, Ex tb</b>	10A, 12A	10A, 12A, 20A
	<b>Ex i, Ex tb</b>	5A	5A
<b>Ambient temperature</b>	<b>Ex e, Ex tb</b>	-40°C ~ +40/55°C	
	<b>Ex i, Ex tb</b>	-40°C ~ +50/60/65°C	

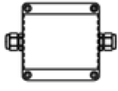
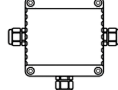
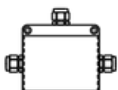

## TL-EX-FH-BH05-Series Explosion-proof Terminal Box

### 4 Proposal Example

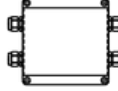
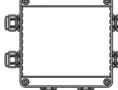
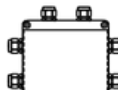
TL-EX-FH-BH05-1	Cable entries	Cable outer dia.
	2XM20	Φ6-Φ12mm
	2XM25	Φ10-Φ14mm
	3XM20	Φ6-Φ12mm
	3XM25	Φ10-Φ14mm
	4XM20	Φ6-Φ12mm
	4XM25	Φ10-Φ14mm

TL-EX-FH-BH05-2	Cable entries	Cable outer dia.
	4XM25	Φ10-Φ14mm
	4XM32	Φ13-Φ19mm
	6XM25	Φ10-Φ14mm
	6XM32	Φ13-Φ19mm
	8XM25	Φ10-Φ14mm
	8XM32	Φ13-Φ19mm

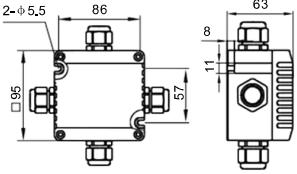
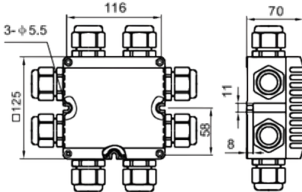
### 5 Outline and Installation Dimension (Dimensions in mm)

 <p>TL-EX-FH-BH05-1</p>	 <p>TL-EX-FH-BH05-2</p>	 <p>Type A Weight:0.6kg</p> <p>Type B Weight:0.5kg</p>
---	---	---

## TL-EX-FH-BX02-Series Explosion-proof Electrical Apparatus

### 1 Application and Features

- Explosion protection ATEX
- Application in hazardous area Zone 1 & 2, Zone 21 & 22
- Seven type enclosure sizes, built-in explosion-proof components (control button, control switch, signal lamp, potentiometer, ammeter, etc.) and terminal blocks.
- The components is rail mounting type, which can be installed on the guide rail quickly and accurately, easy for installation and maintenance.
- Emergency stop button can be equipped with anti misoperation mechanism and padlock (If need).
- Stainless steel exposed fastener, anti dropping structure, easy for installation and maintenance.



### 2 Nomenclature

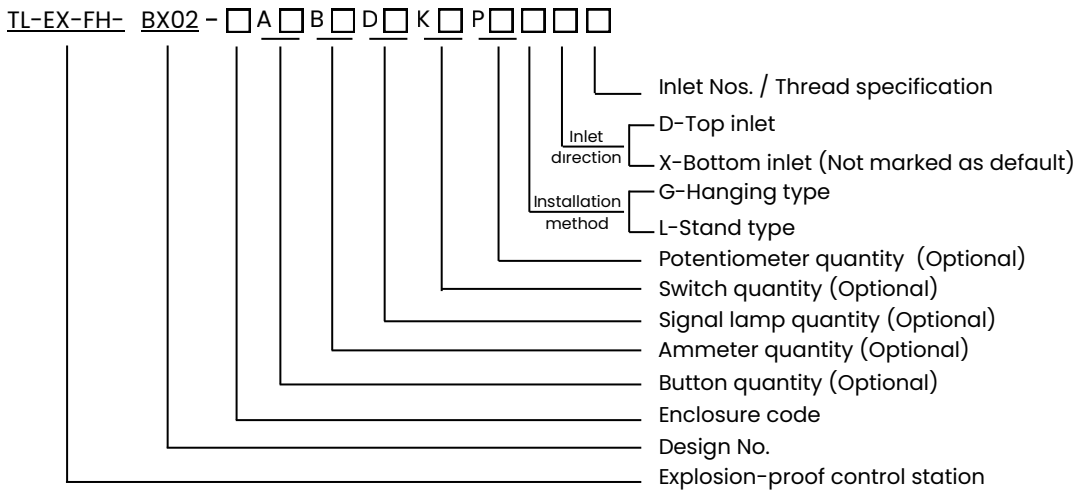

#### Note:

1. Model example: TL-EX-FH-BX02-07A2D2GM25X1.5, 07# enclosure, equipped with two control buttons and two signal lamps, Hanging mounting, one bottom inlet M25x1.5;
2. Specific components plan description refers to the requirements of the drawings;
3. Rain shade can be customized upon request.

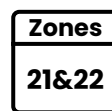
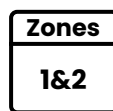
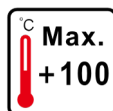
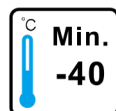









## TL-EX-FH-BX02-Series Explosion-proof Control Station

### 3 Technical Parameter

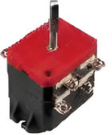
<b>Ex marking</b>	<b>Gas</b>	Ex II 2G Ex db eb IIC T6 Gb	Ex db eb IIC T6 Gb
	<b>Dust</b>	Ex II 2D Ex tb IIIC T80°C Db	Ex tb IIIC T80°C Db
<b>Conformity to standards</b>	IEC60079-0, IEC60079-1, IEC60079-7, IEC60079-31 EN60079-0, EN60079-1, EN60079-7, EN60079-31		
<b>Enclosure materials</b>	<b>Enclosure</b>	Stainless steel(Standard 304, if 316 is needed, please indicate)	
	<b>Rain Shade</b>	Bended steel plate surface powder coated, industrial grey with dark lines texture (RAL7035)or stainless steel 304/316, please note when needed.	
<b>Exposed fastener</b>	Stainless steel, anti-drop structure.		
<b>Rated Voltage</b>	Max. 415V AC, 250V DC		
<b>Rated Current</b>	6A, 10A, 16A		
<b>Wire diameter</b>	≤6A: 0.75~ 2.5mm <sup>2</sup>		
	6A<I≤10A: 1.5~ 2.5mm <sup>2</sup>		
	10A<I≤16A: 2.5mm <sup>2</sup>		
<b>Degree of protection</b>	IP66		
<b>Ambient temperature</b>	-40°C ~ +40/45/50/55/60/65/70°C		
<b>Built-in components</b>	TL-EX-FH-0101 explosion-proof control button		
	TL-EX-FH-0102 explosion-proof signal lamp		
	TL-EX-FH-0101-S explosion-proof control switch		
	TL-EX-FH-0109 explosion-proof ammeter		
<b>Installation method</b>	Hanging type, stand type		
<b>Cable entries</b>	Hanging type	M16x1.5~M63x1.5 The cable gland is not available when delivery, please indicate if necessary	
	Stand type	Only for G1 thread	

### 4 Components and Accessories

				
TL-EX-FH-0101- Control button	TL-EX-FH-0101-A2 Two control button	TL-EX-FH-0102- Signal lamp	TL-EX-FH-0101-A control button with signal lamp	
				
TL-EX-FH-0109- Ammeter	TL-EX-FH-0155 Switch	φ38 operating handle	φ65 Operating handle (padlock available)	Square operating handle

## TL-EX-FH-BX02-Series Explosion-proof Control Station

### 5 Selection Table

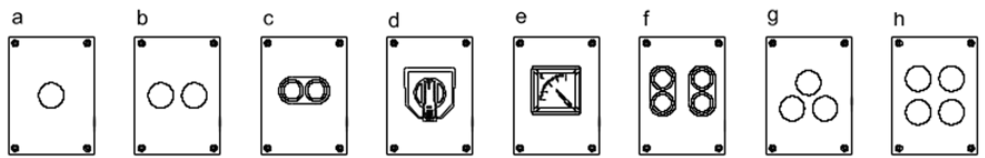
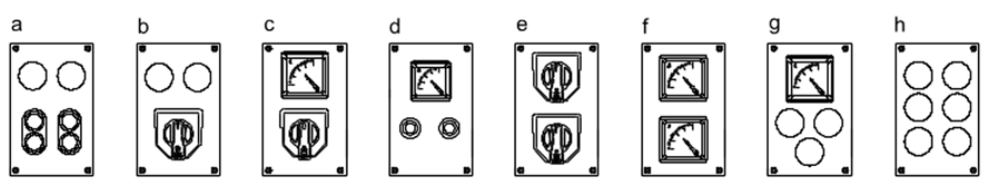
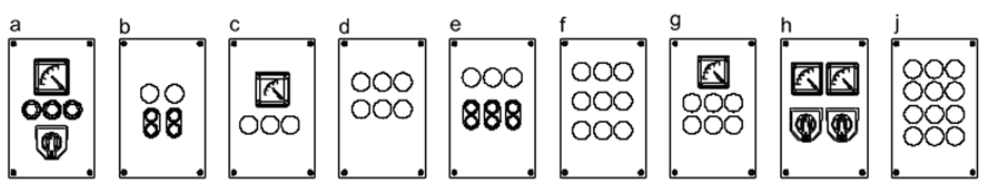
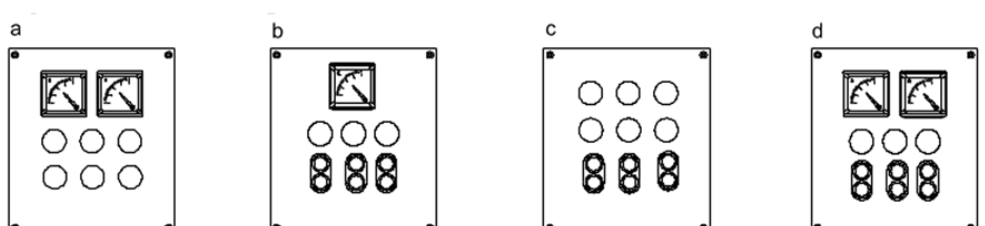
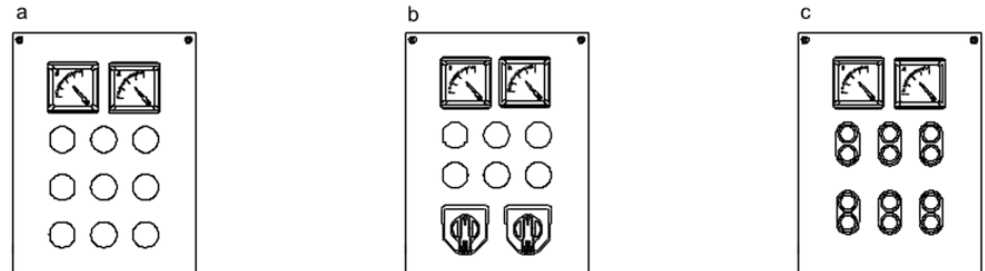
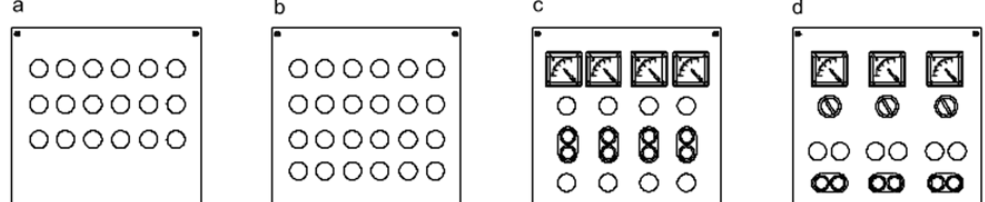
Code	Component layout
03	
07	
11	
15	
19	
21/25	

## TL-EX-FH-BX02-Series Explosion-proof Control Station

### 6 Outline and Installation Dimension (Dimension in mm)

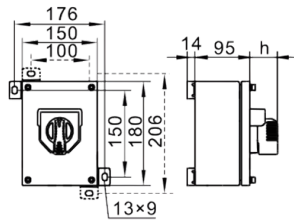

Enclosure 03

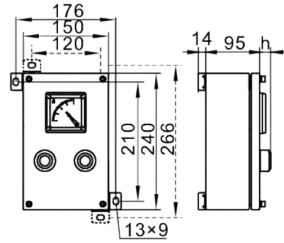

Enclosure 07

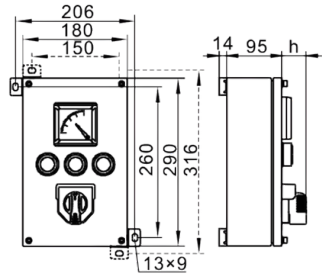

Enclosure 11

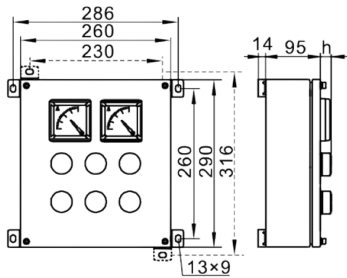

Enclosure 15

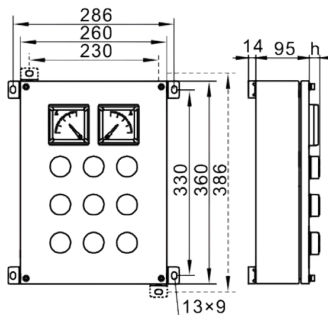

Enclosure 19

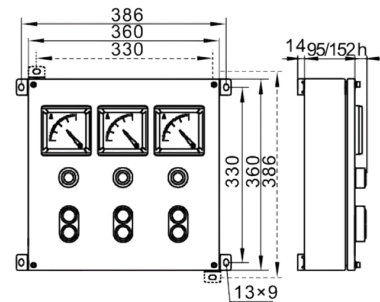

Enclosure 21/25

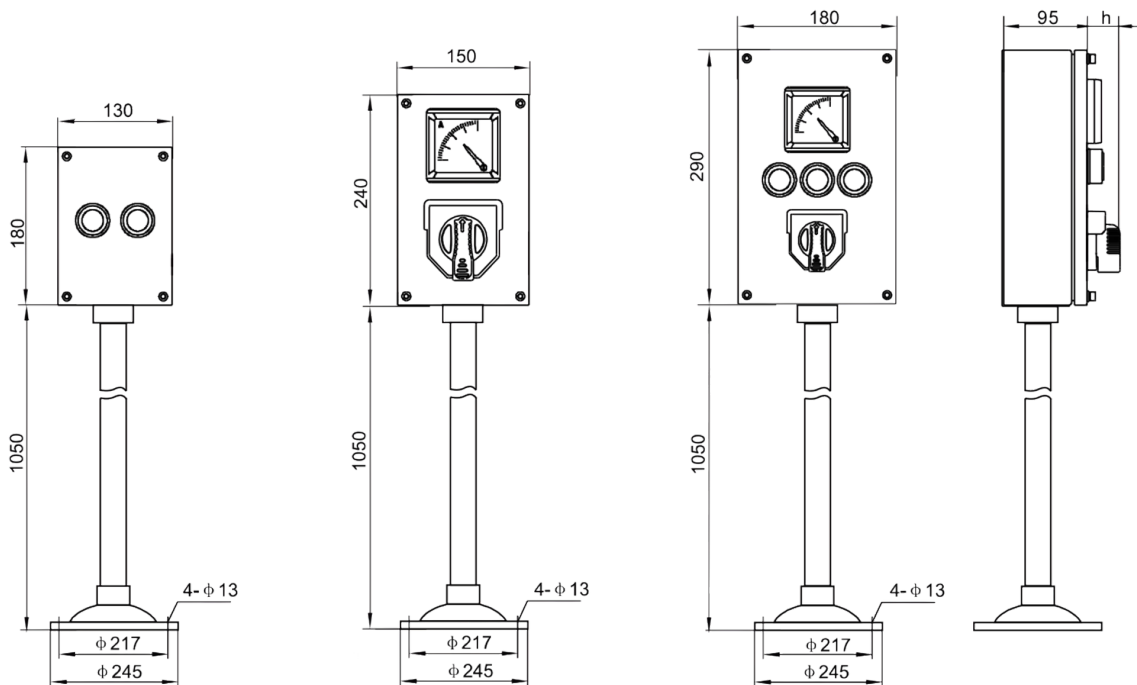

### 7 Height of electrical accessories

Electrical accessories	Frame of ammeter	Standard button	Double Button	Button with key	Self-lock button	Mushroom button	Mushroom button with key	Indicator light	Illuminated button	Control switch S1,S3	Control switch S2	Potentiometer (single turn)	Potentiometer (multi turn)
h(mm)	11	20.5	21.5	38(62)	40	32	45(69)	23.5	20.5	40	42	27	40.5

## TL-EX-FH-BX03-Series Explosion-proof Electrical Apparatus

### 1 Application and Features

- Explosion protection  
ATEX
- Application in hazardous area  
Zone 1 & 2,  
Zone 21 & 22
- Seven type enclosure sizes, built-in explosion-proof components (control button, control switch, signal lamp, potentiometer, ammeter, etc.) and terminal blocks.
- The components is rail mounting type, which can be installed on the guide rail quickly and accurately, easy for installation and maintenance.
- Emergency stop button can be equipped with anti misoperation mechanism and padlock (If need).
- Stainless steel exposed fastener, anti dropping structure, easy for installation and maintenance.



### 2 Nomenclature

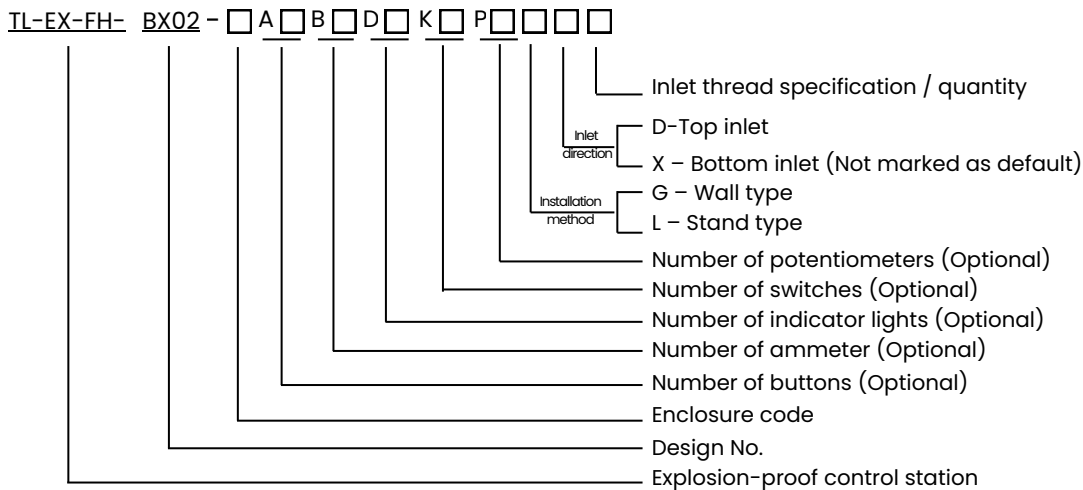

#### Note:

1. Example: TL-EX-FH-BX03-19A2B1GXM25X1,5, 19# enclosure, which with two control buttons, one ammeter, wall mounting type, one bottom inlet M25X1.5;
2. The specific requirements of the components are based on the drawings;
3. The rain shade is customizable by requirements.

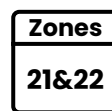
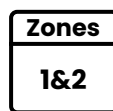
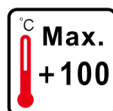
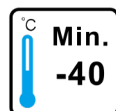









## TL-EX-FH-BX03-Series Explosion-proof Control Station

### 3 Technical Parameter

<b>Ex marking</b>	<b>Gas</b>	Ex II 2G Ex db eb IIC T6 Gb	Ex db eb IIC T6 Gb
	<b>Dust</b>	Ex II 2D Ex tb IIIC T80°C Db	Ex tb IIIC T80°C Db
<b>Conformity to standards</b>	IEC60079-0, IEC60079-1, IEC60079-7, IEC60079-31 EN60079-0, EN60079-1, EN60079-7, EN60079-31		
<b>Enclosure materials</b>	<b>Enclosure</b>	GRP (Polyester resin, glass fibre reinforced), antistatic	
	<b>Rain Shade</b>	Bended steel plate surface powder coated, (black color) industrial grey or stainless steel 304/316, please note when needed.	
<b>Color of enclosure</b>	Black		
<b>Exposed fastener</b>	Stainless steel, exposed fasteners anti-drop structure.		
<b>Rated Voltage</b>	Max. 415V AC, 250V DC		
<b>Rated Current</b>	6A, 10A, 16A		
<b>Wire diameter</b>	≤6A: 0.75~ 2.5mm <sup>2</sup>		
	6A<I≤10A: 1.5~ 2.5mm <sup>2</sup>		
	10A<I≤16A: 2.5mm <sup>2</sup>		
<b>Degree of protection</b>	IP66		
<b>Ambient temperature</b>	-40°C ~ +40/45/50/55/60/65/70°C		
<b>Built-in components</b>	TL-EX-FH-0101 explosion-proof control button		
	TL-EX-FH-0102 explosion-proof signal lamp		
	TL-EX-FH-0101-S explosion-proof control switch		
	TL-EX-FH-0109 explosion-proof ammeter		
<b>Installation method</b>	Wall type and stand type		
<b>Cable entries</b>	Wall type	M16x1.5-M63x1.5, G1/2-G2	
	Stand type	Without cable entry device as default, please note if which is needed. G1 Only	

### 4 Components and Accessories

				
TL-EX-FH-0101- Control button	TL-EX-FH-0101-A2 Double button	TL-EX-FH-0102- Signal lamp	TL-EX-FH-0101-A Illuminated control buttons	
				
TL-EX-FH-0109- Ammeter	TL-EX-FH-0155 Switch	φ38 operating handle	φ65 Operating handle (padlock available)	Square operating handle

## TL-EX-FH-BX03-Series Explosion-proof Control Station

### 5 Selection Table (Dimension in mm)

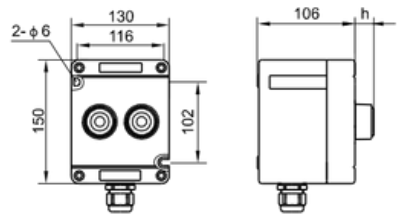
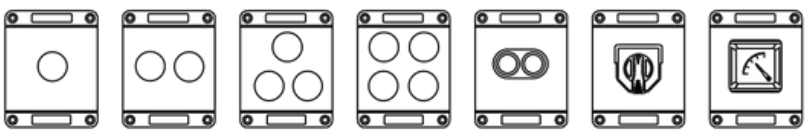
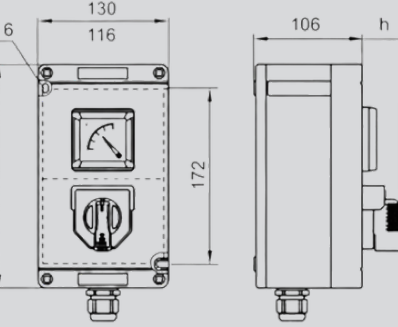
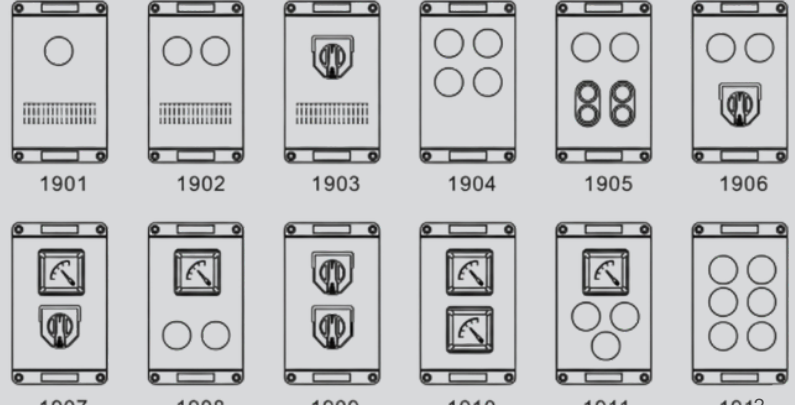
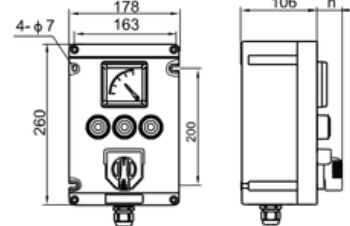
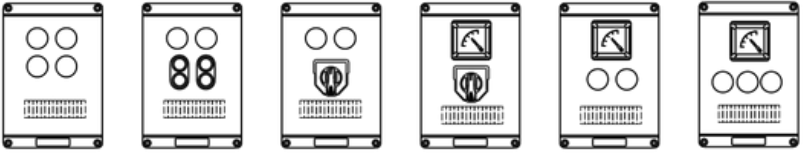
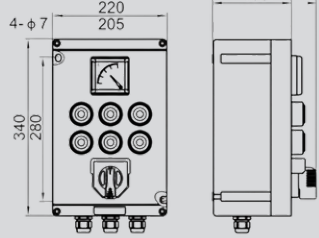
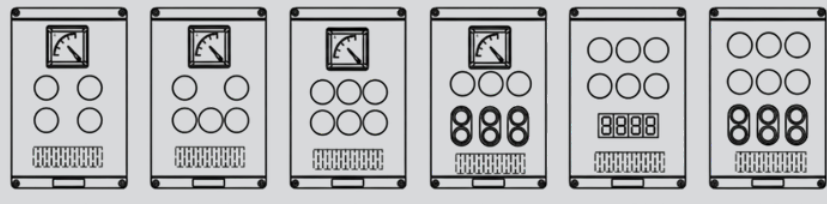
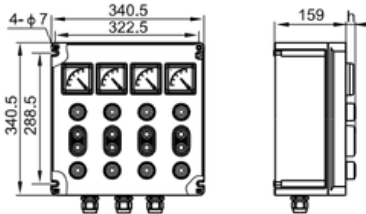
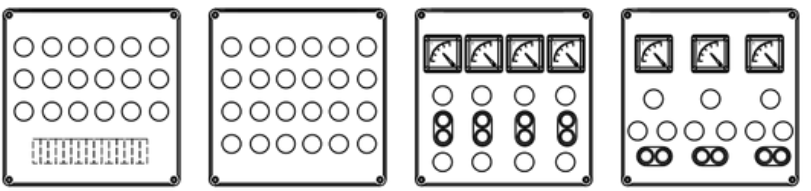
Outline	Component layout
<p><b>15#</b></p> 	 <p>1501 1502 1503 1504 1505 1506 1507</p>
<p><b>19#</b></p> 	 <p>1901 1902 1903 1904 1905 1906 1907 1908 1909 1910 1911 1912</p>
<p><b>21#</b></p> 	 <p>2101 2102 2103 2104 2105 2106</p>
<p><b>25#</b></p> 	 <p>2501 2502 2503 2504 2505 2506</p>
<p><b>29#</b></p> 	 <p>2901 2902 2903 2904</p>

## TL-EX-FH-BX03-Series Explosion-proof Control Station



### 6 Height of electrical accessories

Electrical accessories	Frame of ammeter	Standard button	Double button	Button with key	Self-lock button	Mushroom button	Mushroom button with key	Indicator light	Illuminated button	Control switch S1,S3	Control switch S2	Potentiometer (single turn)	Potentiometer (multi turn)
h(mm)	11	20.5	21.5	38(62)	40	32	45(69)	23.5	20.5	40	42	27	40.5

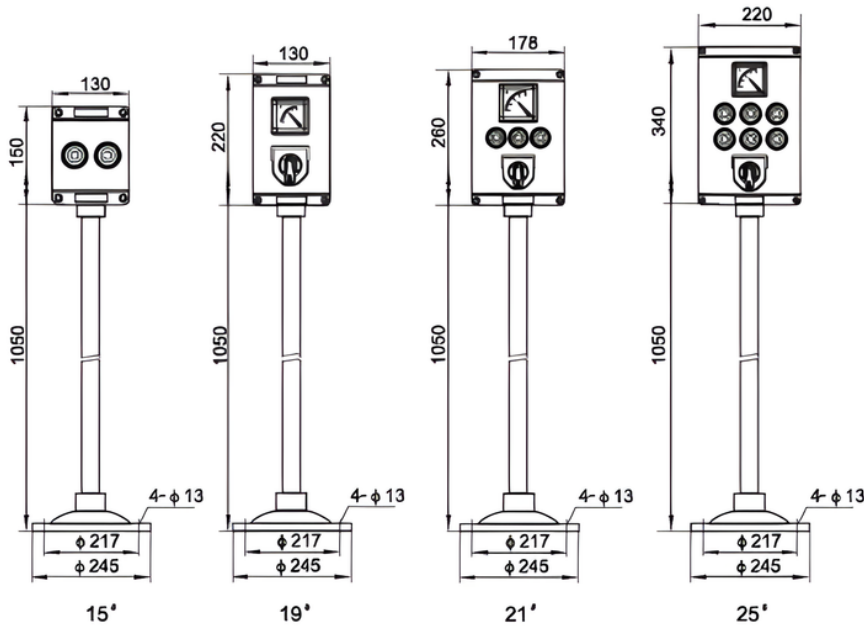
### 7 Outline and Installation Dimension (stand type) (Dimension in mm)



### 8 Accessories list

Item	Picture	Purchase code	Weight (kg)
Stand type connection part		1.01.901.00007	0.3
Pole		1.01.901.00006	3.4
Basis		1.01.901.00005	0.6

## TL-EX-FH-BX05-Series Explosion-proof Electrical Apparatus

### 1 Application and Features

- Explosion protection ATEX
- Application in hazardous area Zone 1 & 2, Zone 21 & 22
- Three type enclosure sizes, built-in explosion-proof components (control button, control switch, signal lamp, potentiometer, ammeter, etc.). The components is rail mounting type, which can be installed on the guide rail quickly and accurately, easy for installation and maintenance
- Component arrangement can be combined upon request.
- Emergency stop can be equipped with anti misoperation mechanism and padlock (if need).
- Stainless steel exposed fastener, anti dropping structure, easy for installation and maintenance.



### 2 Nomenclature

TL-EX-FH- BX05 - □ □ □ □ □ □ □ □

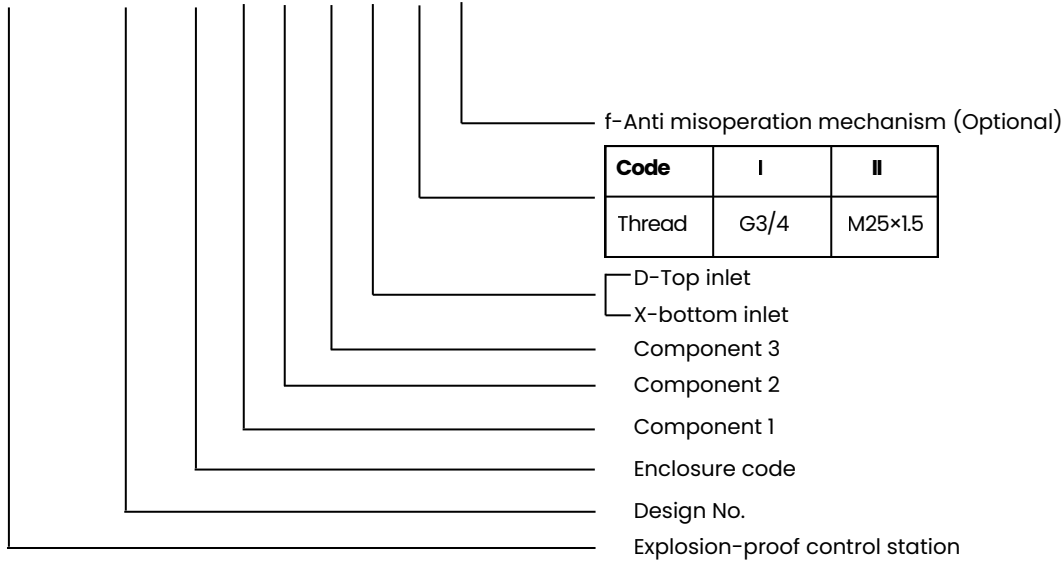

#### Note:

- 1.Built-in components model meanings please refer to Part G Ex components;
- 2.Rain shade can be customized upon request.

Model example:

TL-EX-FH-BX05-3/07R/T1.FA/1/1/02FX1 : 07# enclosure, equipped with one signal lamp, AC/DC 12-36V, and one push button, 1NO+1NC, with marking "T", bottom inlet M25×1.5.

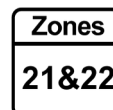
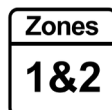
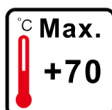









## TL-EX-FH-BX05-Series Explosion-proof Control Station

### 3 Technical Parameter

<b>Ex marking</b>	<b>Gas</b>	Ex II 2G Ex db eb IIC T6 Gb	Ex db eb IIC T6 Gb
	<b>Dust</b>	Ex II 2D Ex tb IIIC T80°C Db	Ex tb IIIC T80°C Db
<b>Conformity to standards</b>	IEC60079-0, IEC60079-1, IEC60079-7, IEC60079-31 EN60079-0, EN60079-1, EN60079-7, EN60079-31		
<b>Enclosure materials</b>	<b>Enclosure</b>	GRP (Polyester resin, glass fibre reinforced), antistatic	
	<b>Rain Shade</b>	Bended steel plate surface powder coated, (black color) industrial grey or stainless steel 304/316, please note when needed.	
<b>Color of enclosure</b>	Black		
<b>Exposed fastener</b>	Stainless steel, exposed fasteners anti-drop structure.		
<b>Rated Voltage</b>	Max. 415V AC, 250V DC		
<b>Rated Current</b>	6A, 10A, 16A		
<b>Wire diameter</b>	≤6A: 0.75~ 2.5mm <sup>2</sup>		
	6A<I≤10A: 1.5~ 2.5mm <sup>2</sup>		
	10A<I≤16A: 2.5mm <sup>2</sup>		
<b>Degree of protection</b>	IP66		
<b>Ambient temperature</b>	-40°C ~ +40/45/50/55/60/65/70°C		
<b>Built-in components</b>	TL-EX-FH-0101 explosion-proof control button		
	TL-EX-FH-0102 explosion-proof signal lamp		
	TL-EX-FH-0101-S explosion-proof control switch		
	TL-EX-FH-0109 explosion-proof ammeter		
<b>Installation method</b>	Hanging type		
<b>Cable entries</b>	Hanging type	M25X1.5,G3/4	
		The cable gland is not available when delivery, please indicate if necessary	

### 4 Components and Accessories

			
TL-EX-FH-0101- Control button	TL-EX-FH-0101-A2 Two control button	TL-EX-FH-0102- Signal lamp	TL-EX-FH-0101-A control buttons with signal lamp
			
TL-EX-FH-0109- Ammeter	φ38 operating handle	φ65 Operating handle (padlock available)	Square operating handle

## TL-EX-FH-BX05-Series Explosion-proof Control Station

### 5 Selection Table (Dimension in mm)

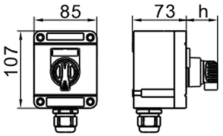
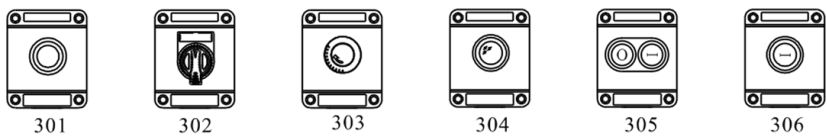
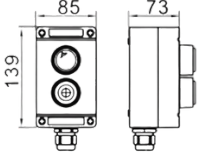
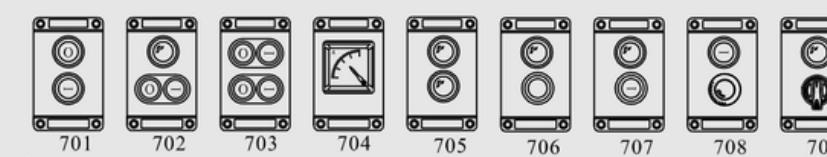
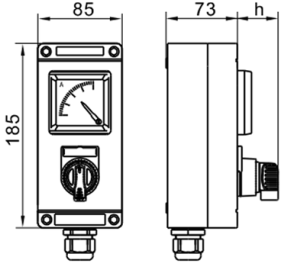
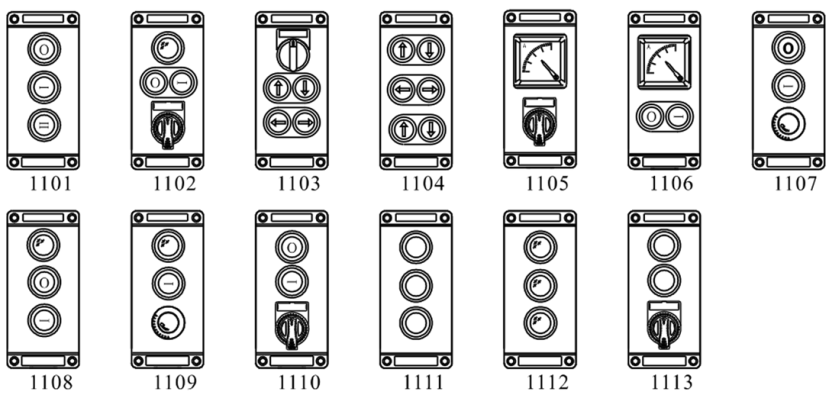
Outline	Component layout
<b>03#</b> 	
<b>07#</b> 	
<b>11#</b> 	

### 6 Outline and Installation Dimension (Dimension in mm)

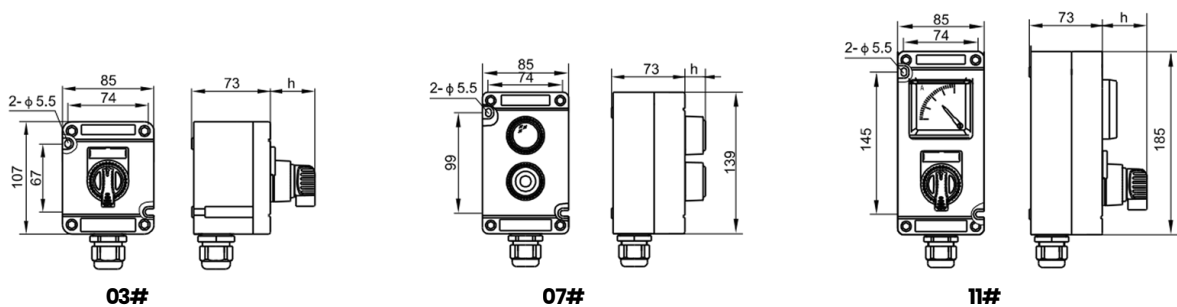

Component Accessories	h (mm)
Meter frame	11
Standard button	20.5
Double button	21.5
Button with key	38(62)
Emergency stop button with self-locking	40
Mushroom head button	32
Mushroom head button with key	45(69)

Component Accessories	h (mm)
Indicator light	23.5
Illuminated control button	20.5
Control switch S1, S3	40
Control switch S2	42
Potentiometer (single -turn)	27
Potentiometer (multi-turn)	40.5
--	--

# TL-EX-FH-0101M-Series Explosion-proof Button / Switch (Board Back Type)

## 1 Application and Features

- Explosion protection ATEX
- Application in hazardous are Zone 1 and Zone 2, Zone 21 and Zone 22
- There are five head types: Standard button, Double heads button, Emergency stop button (rotate to reset), Mushroom head button (self-reset), Mushroom head with key
- The protective cover of the emergency stop button (rotate to reset) and mushroom head button (self-reset) are optional.
- There are two types of installation method: rail mounted type and board back type. Rail mounted type: contact is installed on rail. Board back type: contact is installed behind the cover, quick disassembly structure, easy installation and maintenance.

Electrical accessories



## 2 Nomenclature

TL-EX-FH-0101 - □ □

- None-Rail mounted type
- M-Board back type (Optional)

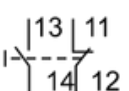
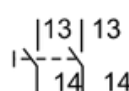
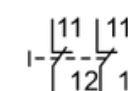
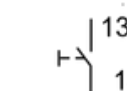
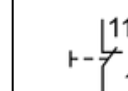
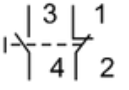
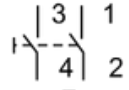
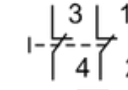
Contact code:	I	II	III	IV	V
	1NO + 1NC	2NO	2NC	1NO	1NC
Contact type of TL-EX-FH-0101					
Contact type of TL-EX-FH-0101M	1NO + 1NC	2NO	2NC	1NO	1NC
				/	/

Explosion-proof button / switch

### ● Electrical accessories (Optional)

TL-EX-FH-0101 - □ / □ □ □

- F-Label holder (Optional)
- E-Electrical accessories (Optional)

Identification code	01	02	03	04	05	21	22	24	25	41	61	81
Identification words	Blank	I	II	On	Start	Blank	0	Off	Stop	Blank	Blank	Blank
	Green	Green	Green	Green	Green	Red	Red	Red	Red	Yellow	White	Blank
	/	White	White	White	White	/	White	White	White	/	/	/

Electrical accessories code

- A1 - Button head
- A2 - Double button head
- A3 - Emergency self-locking button head
- A4 - Mushroom head button
- Y0 - Emergency button with key head

Explosion-proof button head



Without label holder

Note: A yellow ring will be equipped when without label holder.

## TL-EX-FH-0101M-Series Explosion-proof Button / Switch (Board Back Type)

### 3 Technical Parameter

<b>Ex marking</b>	<b>Gas</b>	Ex II 2G Ex db eb IIC Gb	Ex db eb IIC Gb	
	<b>Gas</b>	Ex II 2G Ex eb IIC Gb	Ex eb IIC Gb	
	<b>Dust</b>	Ex II 2D Ex tb IIIC Db	Ex tb IIIC Db	
<b>Conformity to standards</b>		IEC 60079-0, IEC 60079-1, IEC 60079-7, IEC 60079-31 EN 60079-0, EN60079-1, EN60079-7, EN60079-31		
<b>Terminal wire diameter</b>		6A: 0.75 ~ 2.5mm <sup>2</sup> , 10A: 1.5 ~ 2.5mm <sup>2</sup>		
<b>Pole</b>		Rail mounted type: 1(2), Board back type: 2		
<b>Degree of protection</b>		Terminal IP20, IP66 (After assembly with electrical accessories)		
<b>Material</b>	<b>Button enclosure</b>	Nylon(PA66), Polycarbonate(PC)		
	<b>Electrical accessories</b>	Nylon(PA66), Polycarbonate(PC)		
<b>Parameter</b>	<b>Rated voltage</b>	220V~250V AC	380V~415V AC	220V DC
	<b>Rated current</b>	6A, 10A	6A, 10A	0.25A
	<b>Rated voltage</b>	110V DC	60V DC	24V DC
	<b>Rated current</b>	1.6A	0.9A	0.4A
<b>Function</b>	<b>Electrical accessories</b>	Function		Weight
	<b>Button head (A1)</b>	Spring self-resetting		38g
	<b>Double button head (A2)</b>	Spring self-resetting, one button head with two function		60g
	<b>Emergency self-locking button head (A3)</b>	Press to lock, rotate to release		43g
	<b>Mushroom head button (A4)</b>	Mushroom type, spring self-resetting		38g
	<b>Emergency button with key head (Y0)</b>	Press to lock, turn the key to unlock and release		60g
<b>Ambient temperature</b>	<b>Rail mounted type</b>	6A: -40°C ~ +70°C, 10A: -40°C ~ +60°C		
	<b>Board back type</b>	6A: -40°C ~ +70°C, 10A: -40°C ~ +65°C		
<b>Component weight</b>	Rail mounted type (1 pcs)			
	Board back type			

### 4 Outline Dimension of Electrical Accessories (Dimensions in mm)

#### ● Rail mounted (Board back) type

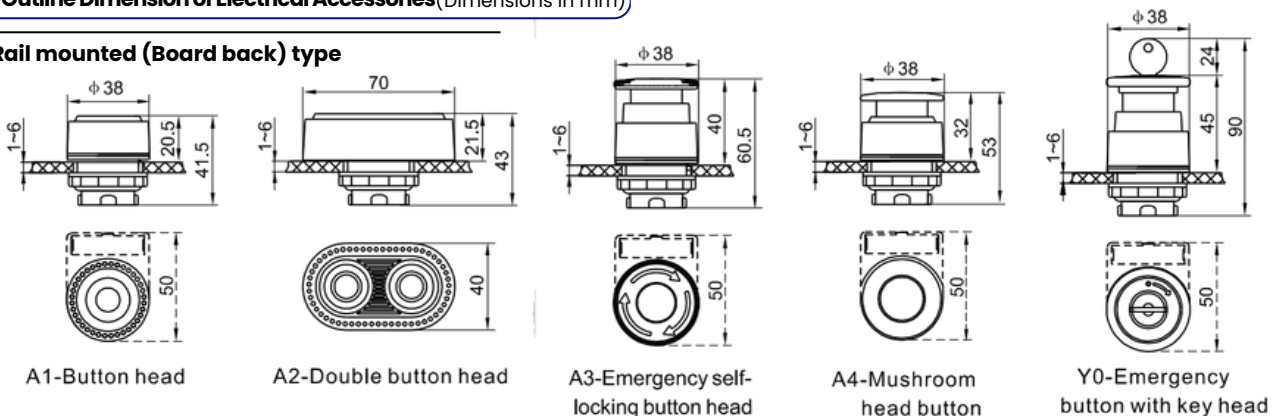

### 5 Component Outline Dimension (Dimensions in mm)

#### ● Rail mounted type

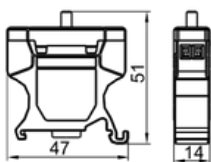

#### ● Board back type

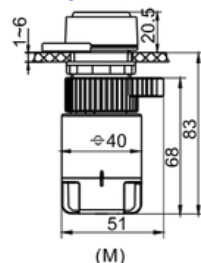

### 6 Installation Distance (Dimensions in mm)

#### ● Rail mounted type

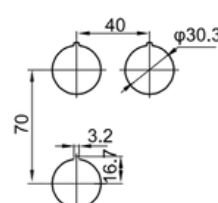

#### ● Board back type

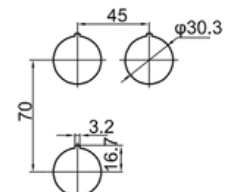

# TL-EX-FH-0101-A(M)-Series Explosion-proof Button / Switch (Board Back Type)

## 1 Application and Features

- Explosion protection ATEX
- Application in hazardous are Zone 1 and Zone 2, Zone 21 and Zone 22
- Five colors: red, green, yellow, blue and white,
- There are two types of installation method: rail mounted type and board back type.
- Rail mounted type: contact is installed on rail.
- Board back type: contact is installed behind the cover, quick disassembly structure, easy installation and maintenance.

Electrical accessories



## 2 Nomenclature

### Component:

TL-EX-FH-0101 - A

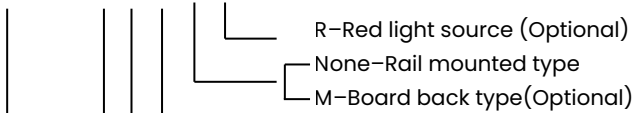

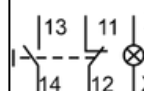
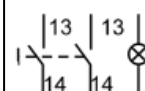
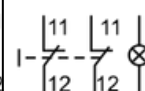
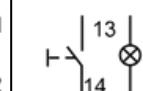
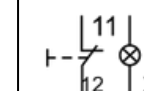
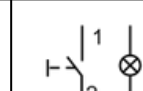
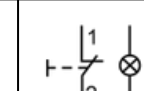
Contact code:	I	II	III	IV	V
Contact type of TL-EX-FH-0101-A	1NO + 1NC 	2NO 	2NC 	1NO 	1NC 
Contact type of TL-EX-FH-0101AM	/	/	/		
Voltage code of signal lamp	01	02	03	04	
Rated voltage (V)	AC/DC12-36	AC/DC48-127	AC220-415	DC220-250	

Button with signal lamp  
Explosion-proof button with signal lamp

### Electrical accessories (Optional)

TL-EX-FH-0101 - A

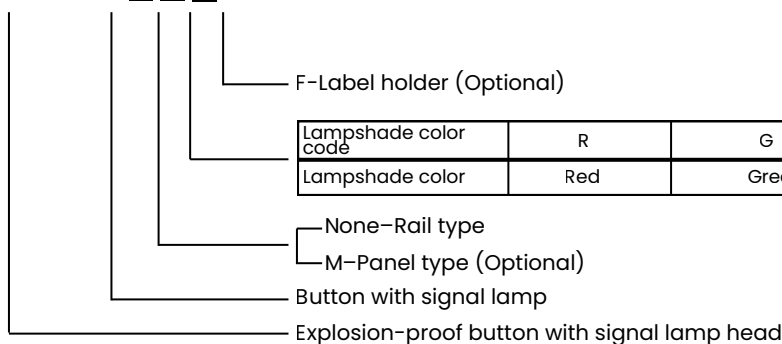

Lampshade color code	R	G	Y	B	W
Lampshade color	Red	Green	Yellow	Blue	White

Note: A yellow ring will be equipped when without label holder.

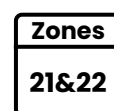
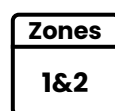
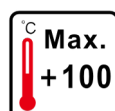
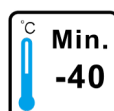

## TL-EX-FH-0101-A(M)-Series Explosion-proof Button / Switch (Board Back Type)

### 3 Technical Parameter

<b>Ex marking</b>	<b>Gas</b>	⊕ II 2G Ex db eb IIC Gb	Ex db eb IIC Gb	
	<b>Gas</b>	⊕ II 2G Ex eb IIC Gb	Ex eb IIC Gb	
	<b>Dust</b>	⊕ II 2D Ex tb IIIC Db	Ex tb IIIC Db	
<b>Conformity to standards</b>		IEC 60079-0, IEC 60079-1, IEC 60079-7, IEC 60079-31 EN 60079-0, EN60079-1, EN60079-7, EN60079-31		
<b>Signal lamp light source</b>		LED		
<b>Signal lamp rated voltage</b>		12~36V AC/DC, 48~127V AC/DC, 220~415V AC, 220~250V DC		
<b>Signal lamp rated power</b>		36V/60V, 127V/1.3W, 415V/3.8W, 250V/1.8W		
<b>Signal lamp ambient temperature</b>		-40°C ~ +70°C		
<b>Signal lamp terminal wire diameter</b>		1.0 ~ 2.5mm <sup>2</sup>		
<b>Electrical accessories lampshade color</b>		Red	Green, Yellow, Blue, White	
<b>Signal lamp light source color</b>		Red	White	
<b>Button terminal wire diameter</b>		6A: 0.75~2.5mm <sup>2</sup> , 10A: 1.5~2.5mm <sup>2</sup>		
<b>Degree of protection</b>		Terminal IP20, IP66 (After assembly with electrical accessories)		
<b>Electrical accessories weight</b>		26g		
<b>Frequency</b>		50Hz/60Hz		
<b>Material</b>	<b>Button enclosure</b>	Nylon(PA66), Polycarbonate(PC)		
	<b>Electrical accessories</b>	Nylon(PA66), Polycarbonate(PC)		
<b>Parameter</b>	<b>Rated voltage</b>	220V~250V AC	380V~415V AC	220V DC
	<b>Rated current</b>	6A, 10A	6A, 10A	0.25A
	<b>Rated voltage</b>	110V DC	60V DC	24V DC
	<b>Rated current</b>	1.6A	0.9A	0.4A
<b>Ambient temperature</b>	<b>Rail mounted type</b>	6A: -40°C ~ +70°C, 10A: -40°C ~ +60°C		
	<b>Board back type</b>	6A: -40°C ~ +70°C, 10A: -40°C ~ +65°C		
<b>Component weight</b>		Rail mounted type: 30g × 3		
		Board back type: 80g		

### 4 Outline Dimension of Electrical Accessories

#### ● Rail mounted type

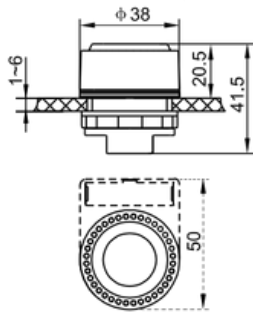

#### ● Board back type

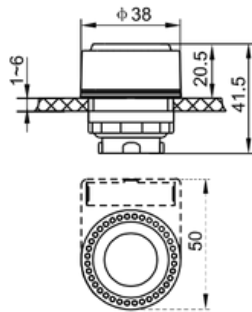

### 5 Component Outline Dimension (Dimensions in mm)

#### ● Rail mounted type

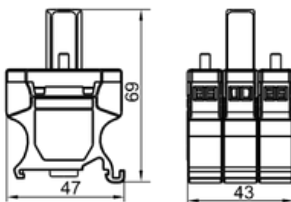

#### ● Board back type

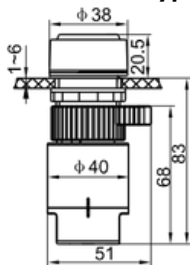

(M)

### 6 Installation Distance (Dimensions in mm)

#### ● Rail mounted type

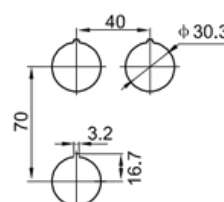

#### ● Board back type

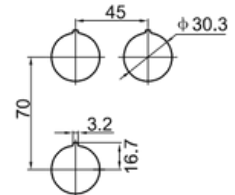

# TL-EX-FH-0101-S1/M-Series Explosion-proof Button / Switch (Board Back Type)

## 1 Application and Features

- Explosion protection ATEX
- Application in hazardous are Zone 1 and Zone 2, Zone 21 and Zone 22
- There are three head types:
  - φ 38 operating handle (S1);
  - φ 65 operating handle (S2, padlock available), square operating handle (S3).
- Installation method: rail mounted type and board back type.
- Rail mounted type: contact is installed on rail.  
Board back type: contact is installed behind the cover, quick disassembly structure, easy installation and maintenance.

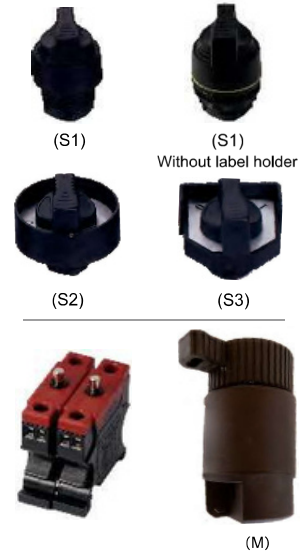

## 2 Nomenclature

TL-EX-FH-0101 - □ □

- None-Rail mounted type
- M-Board back type (Optional)

Switch code	Contact chart	Knob position	Switch code	Contact chart	Knob position	Switch code	Contact chart	Knob position
01			03			05		
02			04			06		

Explosion-proof button / switch

### ● Electrical accessories (Optional)

TL-EX-FH-0101 - □ / □ □ □

- F-Label holder (Optional)
- E-Electrical accessories (Optional)

Identification code	01	02	03	04	05	11	12	13	14	15	16	99
Identification words	0-I	I - II	I-0-II	0--I	0--I	ON OFF	AUTO MAN	LOCAL REMOTE	AUTO STOP MAN	STOP RUN START	LOCK RUN START	Upon request
Color of Identification board	Silver	Silver	Silver	Silver	Silver	Silver	Silver	Silver	Silver	Silver	Silver	Silver
Color of words	Black	Black	Black	Black	Black	Black	Black	Black	Black	Black	Black	Black

- S1-φ 38 Operating handle
- S2-φ 65 Operating handle (Can with padlock)
- S3-Square operating handle

Explosion-proof switch head

Note: A yellow ring will be equipped when without label holder.

## TL-EX-FH-0101-S1/M-Series Explosion-proof Button / Switch (Board Back Type)

### 3 Technical Parameter

<b>Ex marking</b>	<b>Gas</b>	Ex II 2G Ex db eb IIC Gb	Ex db eb IIC Gb	
<b>Ex marking of electrical accessories</b>	<b>Gas</b>	Ex II 2G Ex eb IIC Gb	Ex eb IIC Gb	
	<b>Dust</b>	Ex II 2D Ex tb IIIC Db	Ex tb IIIC Db	
<b>Conformity to standards</b>		IEC 60079-0, IEC 60079-1, IEC 60079-7, IEC 60079-31 EN 60079-0, EN60079-1, EN60079-7, EN60079-31		
<b>Pole</b>		Rail mounted type:1(2), Board back type:2		
<b>Degree of protection</b>		Terminal IP20, IP66 (After assembly with electrical accessories)		
<b>Material</b>	<b>Button enclosure</b>	Nylon(PA66), Polycarbonate(PC)		
	<b>Electrical accessories</b>	Nylon(PA66), Polycarbonate(PC)		
<b>Parameter</b>	<b>Rated voltage</b>	220V~250V AC	380V~415V AC	220V DC
	<b>Rated current</b>	6A, 10A	6A, 10A	0.25A
	<b>Rated voltage</b>	110V DC	60V DC	24V DC
	<b>Rated current</b>	1.6A	0.9A	0.4A
<b>Ambient temperature</b>	<b>Rail mounted type</b>	6A: -40°C ~ +70°C, 10A: -40°C ~ +60°C		
	<b>Board back type</b>	6A: -40°C ~ +70°C, 10A: -40°C ~ +65°C		
<b>Component weight</b>		Rail mounted type: 30g × 3 Board back type: 80g		
<b>Terminal wire diameter</b>		6A: 0.75 ~ 2.5mm <sup>2</sup> , 10A: 1.5 ~ 2.5mm <sup>2</sup>		
<b>Function</b>	<b>Electrical accessories</b>	Function		Weight
	<b>φ 38 Operating handle (S1)</b>	Two-position: Rotate within 90°		36 g
	<b>φ 65 Operating handle (S2)</b>	Three-position: Rotate within 90°, three-position positioning		50g
	<b>Square operating handle (S3)</b>	Three-position left and right self-resetting, three-position right self-resetting φ 65 Operating handle can be with padlock upon request		50g

### 4 Outline Dimension of Electrical Accessories

#### ● Rail mounted (Board back) type

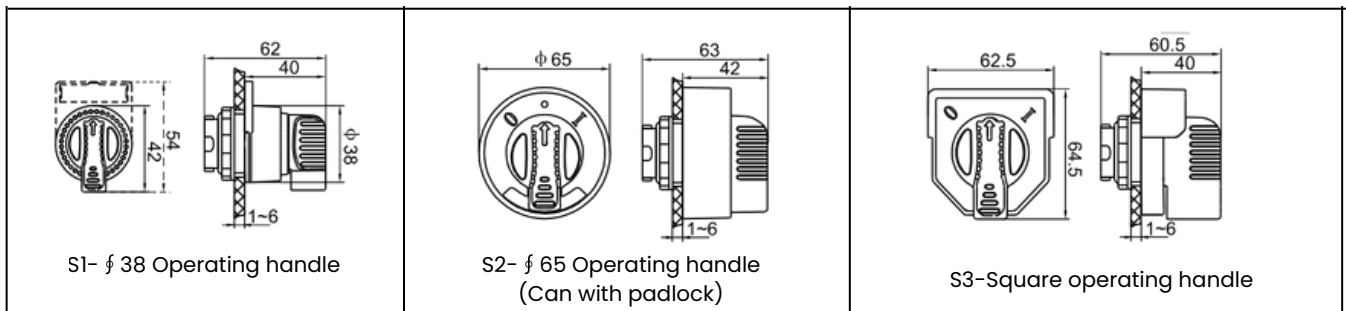

### 5 Component Outline Dimension (Dimensions in mm)

#### ● Rail mounted type

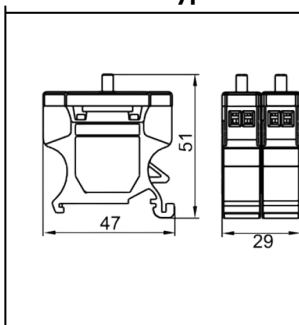

#### ● Board back type

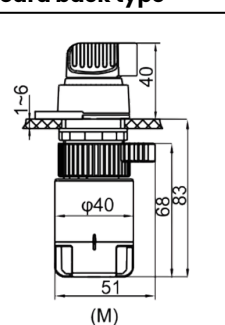

### 6 Installation Distance (Dimensions in mm)

#### ● Rail mounted type

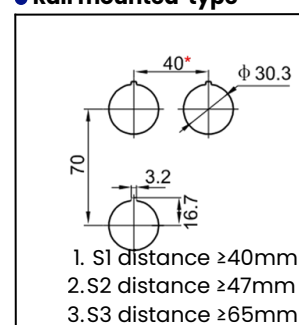

#### ● Board back type

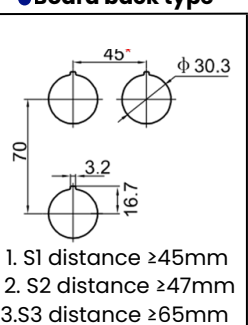

# TL-EX-FH-0101 Y1/ (M)-Series Explosion-proof Button / Switch (Board Back Type)

## 1 Application and Features

- Explosion protection ATEX
- Application in hazardous are Zone 1 and Zone 2, Zone 21 and Zone 22
- Electrical accessories head types: two-position, three-position, three-position left and right self-resetting, three-position right self-resetting.
- There are two types of installation method: rail mounted type and board back type.
- Rail mounted type: contact is installed on rail.
- Board back type: contact is installed behind the cover, quick disassembly structure, easy installation and maintenance.









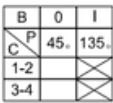

## 2 Nomenclature

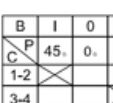
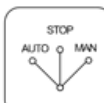
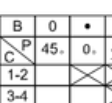
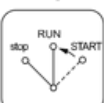
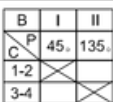

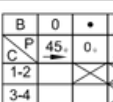
TL-EX-FH-0101 - □ □

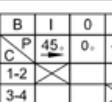
- None-Rail mounted type
- M-Board back type (Optional)

Switch code	Contact chart	Knob position	Switch code	Contact chart	Knob position	Switch code	Contact chart	Knob position
01			03			05		
02			04			06		

Explosion-proof button / switch

### • Electrical accessories (Optional)

TL-EX-FH-0101 - □ / □ □ □

- F-Label holder (Optional)
- Position (Pull out the key)
  - 0- Middle
  - L-Left
  - R-Right

Identification code	01	02	03	04	05	11	12	13	14	15	16	99
Identification words	0-I	I - II	I-0-II	0---I	0---I	ON OFF	AUTO MAN	LOCAL REMOTE	AUTO STOP MAN	STOP RUN START	LOCK RUN START	Upon request
Color of Identification board	Silver	Silver	Silver	Silver	Silver	Silver	Silver	Silver	Silver	Silver	Silver	Silver
Color of words	Black	Black	Black	Black	Black	Black	Black	Black	Black	Black	Black	Black

Y1- Key-operated button head

Explosion-proof key-operated button head

Note: A yellow ring will be equipped when without label holder.

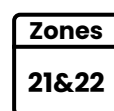
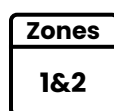
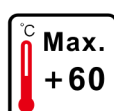
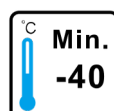

## TL-EX-FH-0101 Y1/ (M)-Series Explosion-proof Button / Switch (Board Back Type)

### 3 Technical Parameter

<b>Ex marking</b>	<b>Gas</b>	⊕ II 2G Ex db eb IIC Gb	Ex db eb IIC Gb	
<b>Ex marking of electrical accessories</b>	<b>Gas</b>	⊕ II 2G Ex eb IIC Gb	Ex eb IIC Gb	
	<b>Dust</b>	⊕ II 2D Ex tb IIIC Db	Ex tb IIIC Db	
<b>Conformity to standards</b>		IEC 60079-0, IEC 60079-1, IEC 60079-7, IEC 60079-31 EN 60079-0, EN60079-1, EN60079-7, EN60079-31		
<b>Pole</b>		Rail mounted type:1(2), Board back type:2		
<b>Degree of protection</b>		Terminal IP20, IP66 (After assembly with electrical accessories)		
<b>Material</b>	<b>Button enclosure</b>	Nylon(PA66), Polycarbonate(PC)		
	<b>Electrical accessories</b>	Nylon(PA66), Polycarbonate(PC)		
<b>Parameter</b>	<b>Rated voltage</b>	220V~250V AC	380V~415V AC	220V DC
	<b>Rated current</b>	6A, 10A	6A, 10A	0.25A
	<b>Rated voltage</b>	110V DC	60V DC	24V DC
	<b>Rated current</b>	1.6A	0.9A	0.4A
<b>Ambient temperature</b>	<b>Rail mounted type</b>	6A: -40°C ~ +70°C, 10A: -40°C ~ +60°C		
	<b>Board back type</b>	6A: -40°C ~ +70°C, 10A: -40°C ~ +65°C		
<b>Component weight</b>		Rail mounted type: 30g × 3 Board back type: 80g		
<b>Terminal wire diameter</b>		6A: 0.75 ~ 2.5mm <sup>2</sup> , 10A: 1.5 ~ 2.5mm <sup>2</sup>		
<b>Function</b>	<b>Electrical accessories</b>	Function		Weight
	<b>∅ 38 Operating handle (S1)</b>	Two-position: Rotate within 90° Three-position: Rotate within 90°, three-position positioning		36g
	<b>∅ 65 Operating handle (S2)</b>	Three-position left and right self-resetting, three-position right self-resetting		50g
	<b>Square operating handle (S3)</b>	∅ 65 Operating handle can be with padlock upon request.		50g

### 4 Outline Dimension of Electrical Accessories

#### • Rail mounted (Board back) type

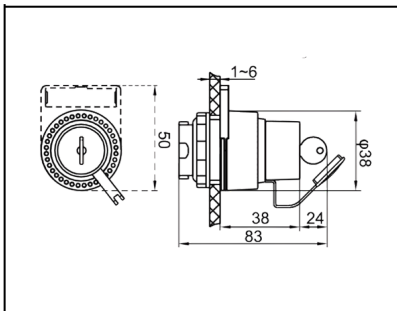

### 5 Component Outline Dimension (Dimensions in mm)

#### • Rail mounted type

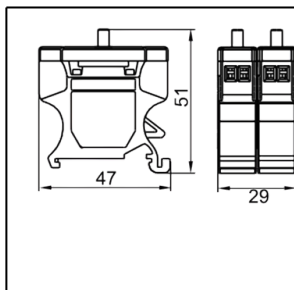

#### • Board back type

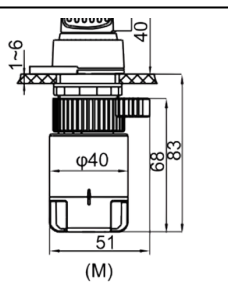

### 6 Installation Distance (Dimensions in mm)

#### • Rail mounted type

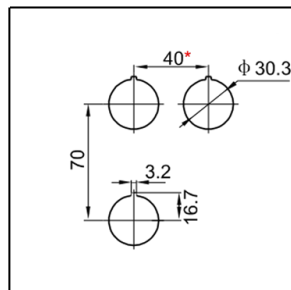

#### • Board back type

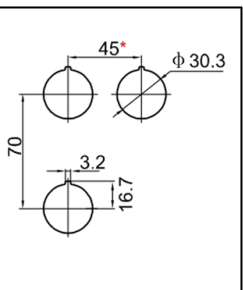

# TL-EX-FH-0102 (M)-Series Explosion-proof Button / Switch (Board Back Type)

## 1 Application and Features

- Explosion protection ATEX
- Application in hazardous area Zone 1 and Zone 2 Zone 21 and Zone 22
- Five colors: red, green, yellow, blue and white.
- There are two types of installation method: rail mounted type and board back type.
- Rail mounted type: contact is installed on rail.
- Board back type: contact is installed behind the cover, quick disassembly structure, easy installation and maintenance.



Without label holder



(M)

## 2 Nomenclature

### • Component.

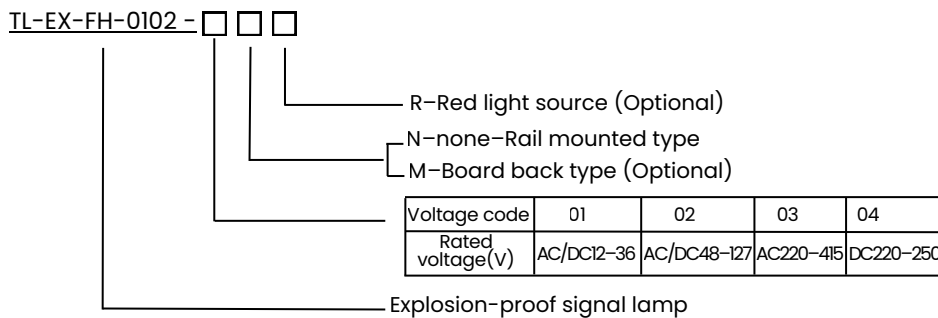

### • Electrical accessories :

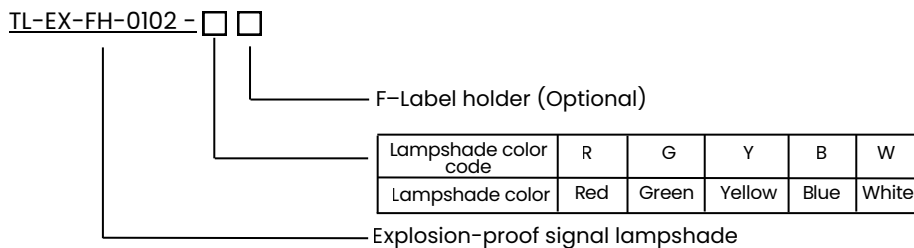

**Note:** A yellow ring will be equipped when without label holder.

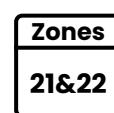
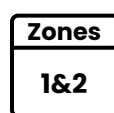
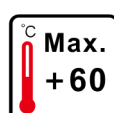
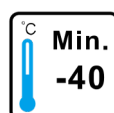

## TL-EX-FH-0102-(M)-Series Explosion-proof Button / Switch (Board Back Type)

### 3 Technical Parameter

<b>Ex marking</b>	<b>Gas</b>	Ex II 2G Ex db eb IIC Gb	Ex db eb IIC Gb
<b>Ex marking of electrical accessories</b>	<b>Gas</b>	Ex II 2G Ex eb IIC Gb	Ex eb IIC Gb
	<b>Dust</b>	Ex II 2D Ex tb IIIC Db	Ex tb IIIC Db
<b>Conformity to standards</b>		IEC 60079-0, IEC 60079-1, IEC 60079-7, IEC 60079-31 EN 60079-0, EN60079-1, EN60079-7, EN60079-31	
<b>Pole</b>		Rail mounted type:1(2), Board back type:2	
<b>Degree of protection</b>		Terminal IP20, IP66 (After assembly with electrical accessories)	
<b>Material</b>	<b>Signal lamp enclosure</b>	Nylon(PA66), Polycarbonate(PC)	
	<b>Electrical accessories</b>	Nylon(PA66), Polycarbonate(PC)	
<b>Electrical accessories lampshade color</b>		Red	Green, Yellow, Blue, White
		Red	White
<b>Light source</b>		LED	
<b>Rated voltage</b>		12~36V AC/DC, 48~127V AC/DC, 220~415V AC, 220~250V DC	
<b>Frequency</b>		50Hz/60Hz	
<b>Rated power</b>		36V/0.6W, 127V/1.3W, 415V/3.8W, 250V/1.8W	
<b>Electrical accessories weight</b>		21g	
<b>Electrical accessories weight</b>		Rail mounted type: 30g (1pcs)	
		Board back type: 75g	
<b>Ambient temperature</b>		-40°C~+70°C	
<b>Terminal wire diameter</b>		0.75~2.5mm <sup>2</sup>	

### 4 Outline Dimension of Electrical Accessories

#### ● Rail mounted (Board back) type

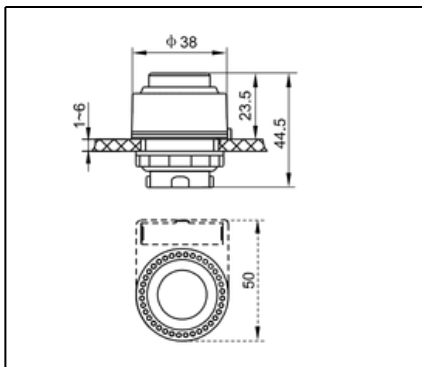

### 5 Component Outline Dimension (Dimensions in mm)

#### ● Rail mounted type

#### ● Board back type

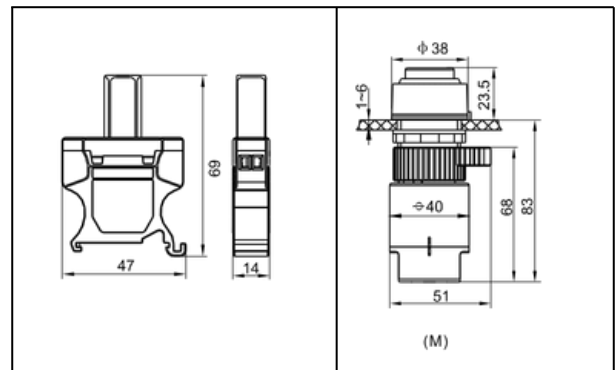

### 6 Installation Distance (Dimensions in mm)

#### ● Rail mounted type

#### ● Board back type

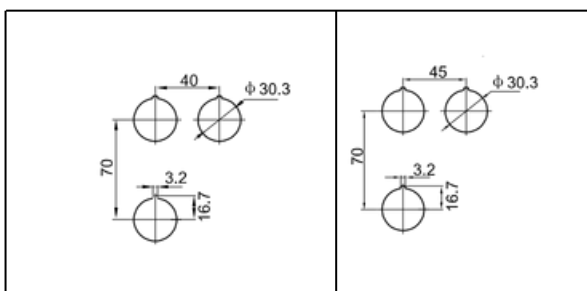

### 7 Schematic Diagram

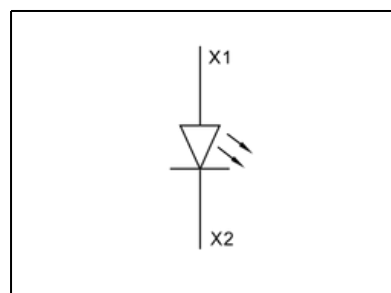

# TL-EX-FH-0101 MD Series Explosion-proof Button / Switch (Board Back Type)

## 1 Application and Features

- Explosion protection  
ATEX
- Application in hazardous area  
Zone 1 and Zone 2  
Zone 21 and Zone 22
- There are five head types:  
Standard button, double heads button, emergency stop button (rotate to reset), mushroom head button (self-reset), mushroom head with key.
- The protective cover of emergency stop button (rotate to reset) and mushroom head button (self-reset) are optional.
- Installation method is panel cable type, quick disassembly structure, easy installation and maintenance.



## 2 Nomenclature

### • Component:

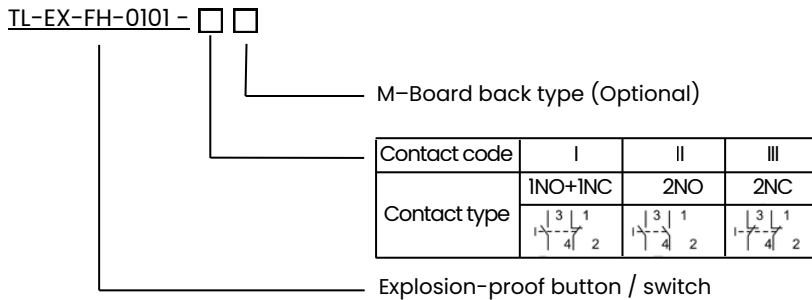

### • Electrical accessories:

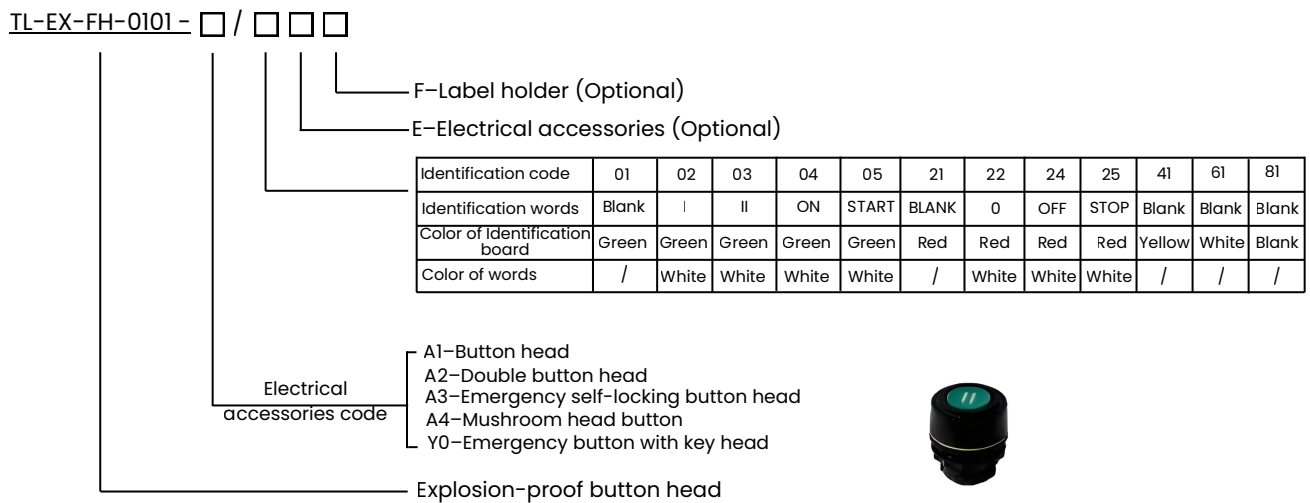

Note: A yellow ring will be equipped when without label holder.

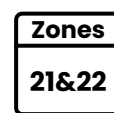
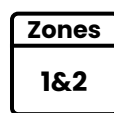
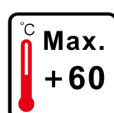
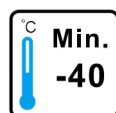

## TL-EX-FH-0101 MD Series Explosion-proof Button / Switch (Board Back Type)

### 3 Technical Parameter

<b>Ex marking of button</b>	<b>Gas</b>	Ex II 2G Ex db eb IIC T6/T5 Gb	Ex db eb IIC T6/T5 Gb	
	<b>Dust</b>	Ex II 2D Ex tb IIIC T80/T95°C Db	Ex tb IIIC T80/T95°C Db	
<b>Ex marking of electrical accessories</b>	<b>Gas</b>	Ex II 2G Ex eb IIC Gb	Ex eb IIC Gb	
	<b>Dust</b>	Ex II 2D Ex tb IIIC Db	Ex tb IIIC Db	
<b>Conformity to standards</b>		IEC 60079-0, IEC 60079-1, IEC 60079-7, IEC 60079-31 EN 60079-0, EN 60079-1, EN 60079-7, EN 60079-31		
<b>Material</b>	<b>Button enclosure</b>	Nylon(PA66)		
	<b>Electrical accessories</b>	Nylon(PA66), Polycarbonate(PC)		
<b>Parameter</b>	Rated voltage	220V-250V AC	380V-415V AC	220V DC
	Rated current	6A, 10A	6A, 10A	0.25A
	Rated voltage	110V DC	60V DC	24V DC
	Rated current	1.6A	0.9A	0.4A
<b>Pole</b>		2		
<b>Degree of protection</b>		IP66 (After assembly with electrical accessories)		
<b>Function</b>	Electrical accessories	Function		Weight
	Button head (A1)	Spring self-resetting		38g
	Double button head(A2)	Spring self-resetting, one button head with two function		60g
	Emergency self-locking button head (A3)	Press to lock, turn to release		43g
	Mushroom head button(A4)	Mushroom type, spring self-resetting		38g
Emergency button with key head(Y0)	Press to lock, key to unlock and release		60g	
<b>Component weight</b>		Board back cable type		90g
<b>Ambient temperature</b>	Rated current	Ambient temperature	Gas	Dust
	6A	-40°C~+55°C -40°C~+65°C	T6 T5	T80°C T95°C
<b>Temperature class</b>	10A	-40°C~+50°C -40°C~+55°C	T6 T5	T80°C T95°C
	<b>Terminal wire diameter</b>		6A:0.75~2.5mm <sup>2</sup> , 10A:1.5~2.5mm <sup>2</sup>	
<b>Available cable outer diameter</b>		Φ6~Φ11 mm, Φ9~Φ13mm		

### 4 Outline Dimension of Electrical Accessories (Dimensions in mm)

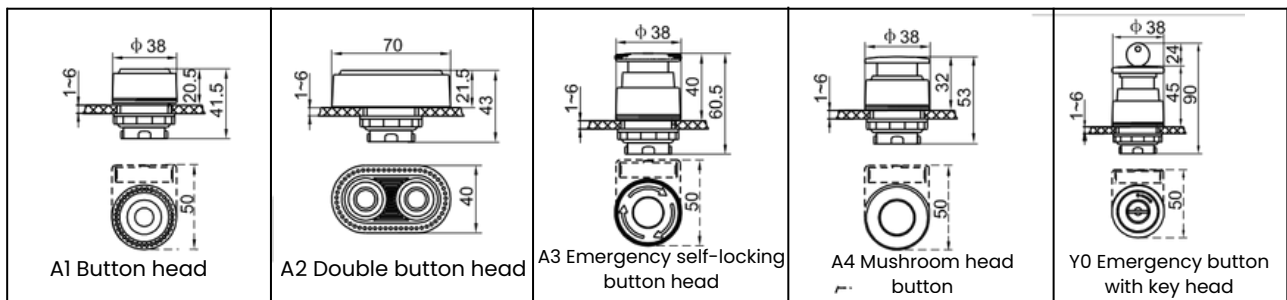

### 5 Component Outline Dimension (Dimensions in mm)

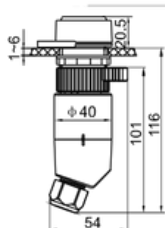

### 6 Installation Distance (Dimensions in mm)

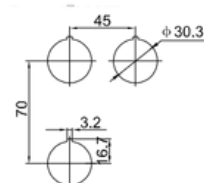

# TL-EX-FH-0101 AMD Series Explosion-proof Button With Signal Lamp (Board Back Type)

## 3 Application and Features

- Explosion protection ATEX
- Application in hazardous area Zone 1 and Zone 2 Zone 21 and Zone 22
- Five colors: red, green, yellow, blue and white.
- Installation method is panel cable type, quick disassembly structure, easy installation and maintenance.



Without label holder

## 2 Nomenclature

### • Component:

TL-EX-FH-0101 - A

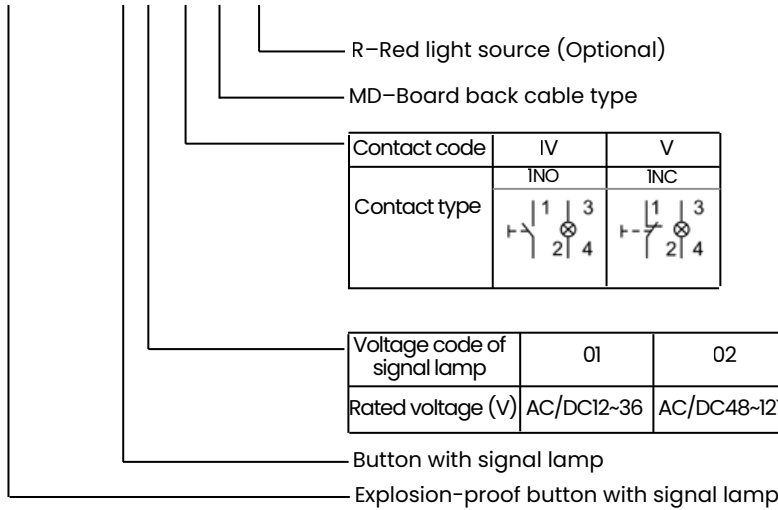

### •Electrical accessories:

TL-EX-FH-0101 - A

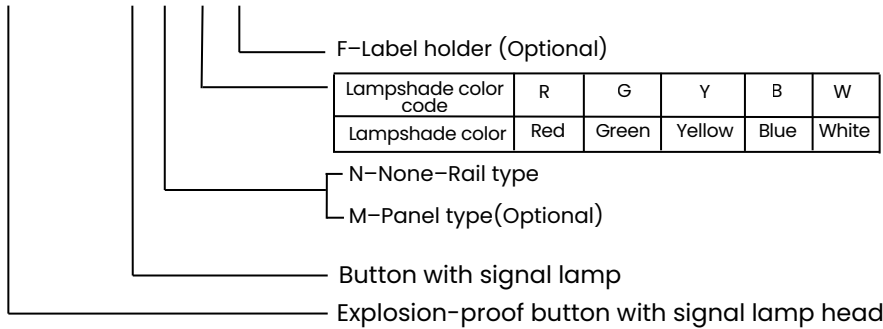

Note: A yellow ring will be equipped when without label holder.

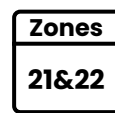
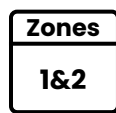
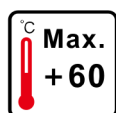

## TL-EX-FH-0101 AMD Series Explosion-proof Button With Signal Lamp (Board Back Type)

### 3 Technical Parameter

<b>Ex marking of button</b>	<b>Gas</b>	Ex II 2G Ex db eb IIC T6/T5 Gb	Ex db eb IIC T6/T5 Gb		
	<b>Dust</b>	Ex II 2D Ex tb IIIC T80/T95°C Db	Ex tb IIIC T80/T95°C Db		
<b>Ex marking of electrical accessories</b>	<b>Gas</b>	Ex II 2G Ex eb IIC Gb	Ex eb IIC Gb		
	<b>Dust</b>	Ex II 2D Ex tb IIIC Db	Ex tb IIIC Db		
<b>Conformity to standards</b>		IEC 60079-0, IEC 60079-1, IEC 60079-7, IEC 60079-31 EN 60079-0, EN 60079-1, EN 60079-7, EN 60079-31			
<b>Material</b>	<b>Button enclosure</b>	Nylon(PA66)			
	<b>Electrical accessories</b>	Nylon(PA66), Polycarbonate(PC)			
<b>Electrical accessories lampshade color</b>		Red	Green, Yellow, Blue, White		
<b>Signal lamp light source color</b>		Red			
<b>Signal lamp light source</b>		LED			
<b>Signal lamp rated voltage</b>		12~36V AC/DC, 48~127V AC/DC, 220~415V AC, 220~250V DC			
<b>Signal lamp rated power</b>		36V/0.6W, 127V/1.3W, 415V/3.8W, 250V/1.8W			
<b>Button parameters</b>	Rated voltage	220V~250V AC	380V~415V AC	220V DC	
	Rated current	6A, 10A	6A, 10A	0.25A	
	Rated voltage	110V DC	60V DC	24V DC	
	Rated current	1.6A	0.9A	0.4A	
<b>Frequency</b>		50Hz/60Hz			
<b>Degree of protection</b>		IP66(After assembly with electrical accessories)			
<b>Electrical accessories weight</b>		26g			
<b>Component weight</b>		Board back cable type: 90g			
<b>Ambient temperature</b>	Rated current	Ambient temperature	Gas	Dust	
		6A	-40°C~+55°C	T6	T80°C
	Temperature class	6A	-40°C~+65°C	T5	T95°C
		10A	-40°C~+50°C	T6	T80°C
10A	-40°C~+55°C	T5	T95°C		
<b>Terminal wire diameter</b>		6A, 0.75~2.5mm <sup>2</sup> , 10A, 1.5~2.5mm <sup>2</sup>			
<b>Available cable outer diameter</b>		Φ6-Φ11 mm			

### 4 Outline Dimension of Electrical Accessories

(Dimensions in mm)

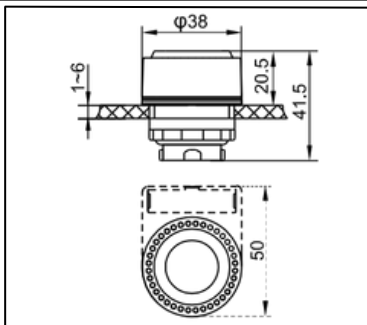

### 5 Component Outline Dimension

(Dimensions in mm)

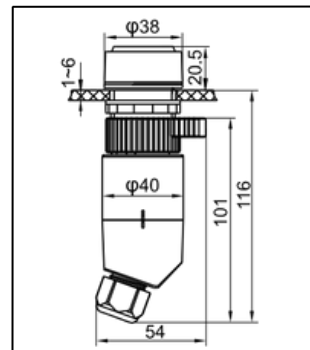

### 6 Installation Distance (Dimensions in mm)

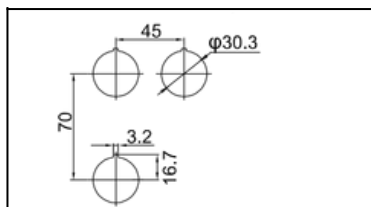

# TL-EX-FH-0101-S/MD Series Explosion-proof Button/Switch (Board back cable type)

## 1 Application and Features

- Explosion protection ATEX
- Application in hazardous area Zone 1 and Zone 2 Zone 21 and Zone 22
- There are three head types:  $\phi$ 38 operating handle (S1),  $\phi$ 65 operating handle (S2, padlock available), square operating handle (S3).
- Installation method is panel cable type, quick disassembly structure, easy installation and maintenance.



## 2 Nomenclature

### •Component

TL-EX-FH-0101 - □ □

MD-Board back cable type

Switch code	Contact chart	Knob position	Switch code	Contact chart	Knob position	Switch code	Contact chart	Knob position
01			03			05		
02			04			06		

Explosion-proof button/switch

### •Electrical accessories

TL-EX-FH-0101 - □ / □ / □

F-Label holder (Optional)

Identification code	01	02	03	04	05	11	12	13	14	15	16	99
Identification words	O-I	I-II	I-0-II	O $\leftrightarrow$ I	O $\leftrightarrow$ I	ON OFF	AUTO MAN	Local Remote	AUTO STOP MAN	STOP $\rightarrow$ RUN $\leftarrow$ START	$\leftarrow$ RUN $\leftarrow$ START	Upon request
Color of identification board	Silver	Silver	Silver	Silver	Silver	Silver	Silver	Silver	Silver	Silver	Silver	Silver
Color of words	Black	Black	Black	Black	Black	Black	Black	Black	Black	Black	Black	Black

- S1- $\phi$ 38 Operating handle
- S2- $\phi$ 65 Operating handle (Can with padlock)
- S3-Square operating handle

Note: A yellow ring will be equipped when without label holder.

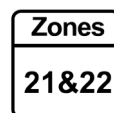
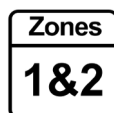
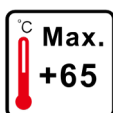

## TL-EX-FH-0101-S/MD Series Explosion-proof Button/Switch (Board back cable type)

### 3 Technical Parameter

Ex marking of button	Gas	Ex II 2G Ex db eb IIC T6/T5 Gb	Ex db eb IIC T6/T5 Gb	
	Dust	Ex II 2D Ex tb IIIC T80/T95°C Db	Ex tb IIIC T80/T95°C Db	
Ex marking of electrical accessories	Gas	Ex II 2G Ex eb IIC Gb	Ex eb IIC Gb	
	Dust	Ex II 2D Ex tb IIIC Db	Ex tb IIIC Db	
Conformity to standards		IEC 60079-0, IEC 60079-1, IEC 60079-7, IEC 60079-31 EN 60079-0, EN 60079-1, EN 60079-7, EN 60079-31		
Material	Button enclosure	Nylon(PA66)		
	Electrical accessories	Nylon(PA66), Polycarbonate(PC)		
Parameter	Rated voltage	220V-250V AC	380V-415V AC	220V DC
	Rated current	6A, 10A	6A, 10A	0.25A
	Rated voltage	110V DC	60V DC	24V DC
	Rated current	1.6A	0.9A	0.4A
Pole		2		
Degree of protection		IP66 (After assembly with electrical accessories)		
Function	Electrical accessories	Two-position: Rotate within 90°.		Weight
	Φ 38 Operating handle (S1)	Two-position: Rotate within 90°.		38g
	Φ 65 Operating handle (S2)	Three-position: Rotate within 90°, three-position positioning. Three-position left and right self-resetting, three-position right self-resetting.		60g
	Square operating handle (S3)	Φ 65 Operating handle can be with padlock upon request.		43g
Component weight		Board back cable type		90g
Ambient temperature	Rated current	Ambient temperature	Gas	Dust
	6A	-40°C~+55°C -40°C~+65°C	T6 T5	T80°C T95°C
Temperature class	10A	-40°C~+50°C -40°C~+55°C	T6 T5	T80°C T95°C
	Terminal wire diameter		6A, 0.75~2.5mm <sup>2</sup> ; 10A, 1.5~2.5mm <sup>2</sup>	
Available cable outer diameter		Φ6~Φ11 mm		

### 4 Outline Dimension of Electrical Accessories (Dimensions in mm)

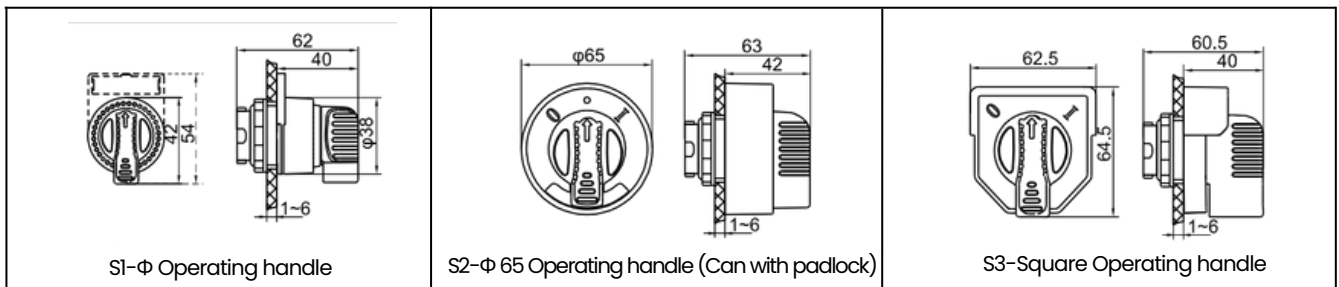

### 5 Component Outline Dimension (Dimensions in mm)

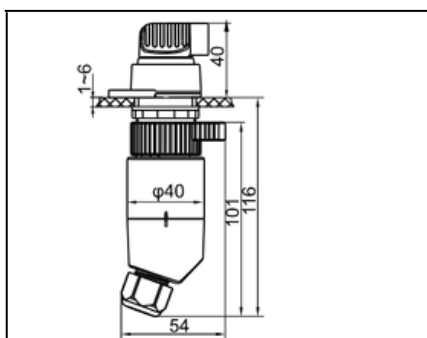

### 6 Installation Distance (Dimensions in mm)

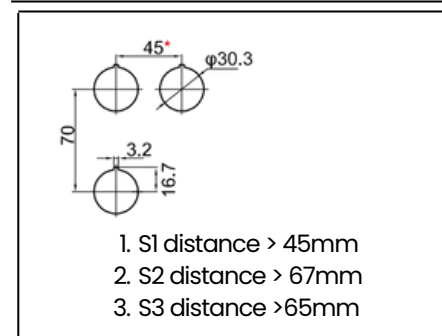

# TL-EX-FH-0101-Y1/MD Series Explosion-proof Button/Switch (Board back cable type)

## 1 Application and Features

- Explosion protection  
ATEX
- Application in hazardous area  
Zone 1 and Zone 2  
Zone 21 and Zone 22
- Electrical accessories head types: two-position, three-position, three-position left and right self-resetting, three-position right self-resetting.
- Installation method is panel cable type, quick disassembly structure, easy installation and maintenance.













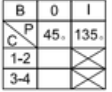

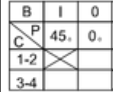
Electrical accessories (Y1)

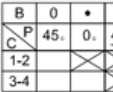
## 2 Nomenclature

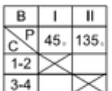
### •Component

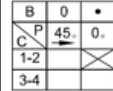
TL-EX-FH-0101 - □ □

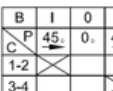
MD-Board back cable type

Switch code	Contact chart	Knob position	Switch code	Contact chart	Knob position	Switch code	Contact chart	Knob position
01			03			05		
02			04			06		

Explosion-proof button/switch

### •Electrical accessories

TL-EX-FH-0101 - □ / □ / □ □

F-Label holder (Optional)

Position  
(Pull out the key)  
0- Middle  
1- Left  
2- Right

Identification code	01	02	03	04	05	11	12	13	14	15	16	99
Identification words	O-I	I-II	I-0-II	O←-I	O←-II	ON OFF	AUTO MAN	Local Remote	AUTO STOP MAN	STOP→RUN←START	LOCK←RUN←START	Upon request
Color of identification board	Silver	Silver	Silver	Silver	Silver	Silver	Silver	Silver	Silver	Silver	Silver	Silver
Color of words	Black	Black	Black	Black	Black	Black	Black	Black	Black	Black	Black	Black

Y1-Key-operated head

Explosion-proof key-operated button head

Note: A yellow ring will be equipped when without label holder.

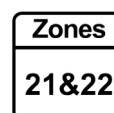
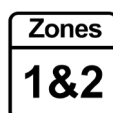
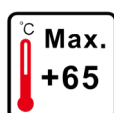
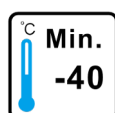

## TL-EX-FH-0101-S/MD Series Explosion-proof Button/Switch (Board back cable type)

### 3 Technical Parameter

Ex marking of button	Gas	Ex II 2G Ex db eb IIC T6/T5 Gb	Ex db eb IIC T6/T5 Gb	
	Dust	Ex II 2D Ex tb IIIC T80/T95°C Db	Ex tb IIIC T80/T95°C Db	
Ex marking of electrical accessories	Gas	Ex II 2G Ex eb IIC Gb	Ex eb IIC Gb	
	Dust	Ex II 2D Ex tb IIIC Db	Ex tb IIIC Db	
Conformity to standards		IEC 60079-0, IEC 60079-1, IEC 60079-7, IEC 60079-31 EN 60079-0, EN 60079-1, EN 60079-7, EN 60079-31		
Material	Button enclosure	Nylon(PA66)		
	Electrical accessories	Nylon(PA66), Polycarbonate(PC)		
Parameter	Rated voltage	220V-250V AC	380V-415V AC	220V DC
	Rated current	6A, 10A	6A, 10A	0.25A
	Rated voltage	110V DC	60V DC	24V DC
	Rated current	1.6A	0.9A	0.4A
Pole		2		
Degree of protection		IP66 (After assembly with electrical accessories)		
Function	Electrical accessories	Two-position: Rotate within 90°.		Weight
	Φ 38 Operating handle (S1)	Two-position: Rotate within 90°.		38g
	Φ 65 Operating handle (S2)	Three-position: Rotate within 90°, three-position positioning. Three-position left and right self-resetting, three-position right self-resetting.		60g
	Square operating handle (S3)	Φ 65 Operating handle can be with padlock upon request.		43g
Component weight		Board back cable type		90g
Ambient temperature	Rated current	Ambient temperature	Gas	Dust
	6A	-40°C~+55°C -40°C~+65°C	T6 T5	T80°C T95°C
Temperature class	10A	-40°C~+50°C -40°C~+55°C	T6 T5	T80°C T95°C
Terminal wire diameter		6A, 0.75~2.5mm <sup>2</sup> ; 10A, 1.5~2.5mm <sup>2</sup>		
Available cable outer diameter		Φ6~Φ11 mm		

### 4 Outline Dimension of Electrical Accessories (Dimensions in mm)

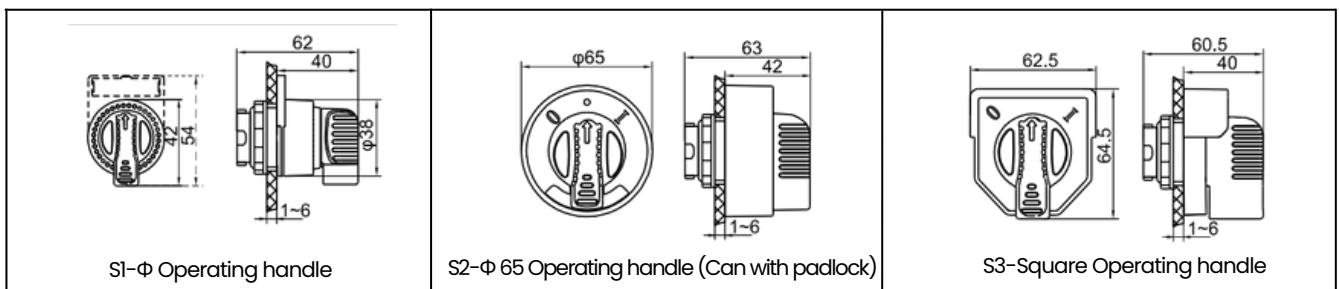

### 5 Component Outline Dimension (Dimensions in mm)

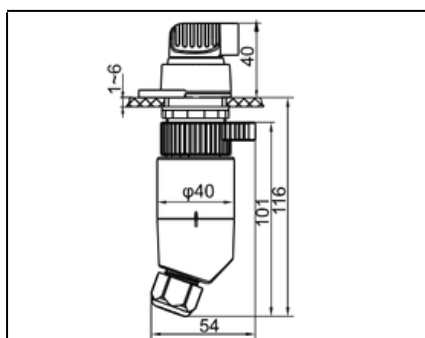

### 6 Installation Distance (Dimensions in mm)

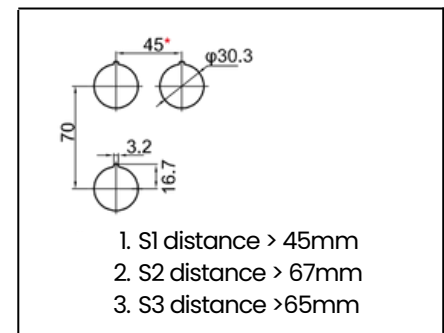

## TL-EX-FH-0102-MD Series Explosion-proof Signal Lamp (Board back cable type)

### 1 Application and Features

- Explosion protection  
ATEX
- Application in hazardous area  
Zone 1 and Zone 2  
Zone 21 and Zone 22
- Five colors: red, green, yellow, blue and white.
- Installation method is panel cable type, quick disassembly structure, easy installation and maintenance.

Electrical accessories



Without label holder

### 2 Nomenclature

#### •Component

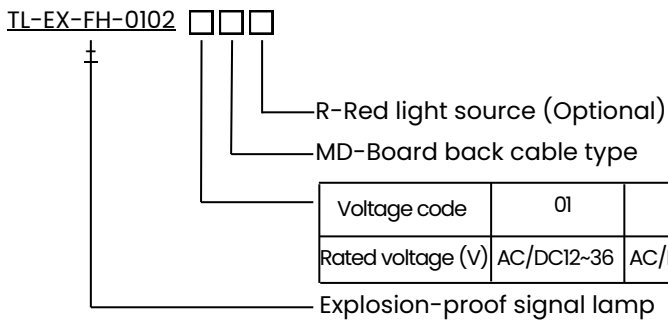

#### •Electrical accessories

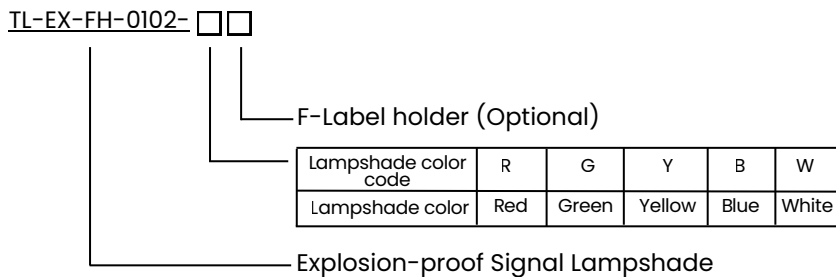

Note: A yellow ring will be equipped when without label holder.

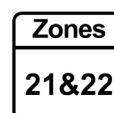
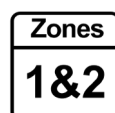
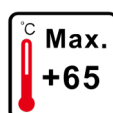

## TL-EX-FH-0102-MD Series Explosion-proof Signal Lamp (Board back cable type)

### 3 Technical Parameter

Ex marking of signal lamp	Gas	⊕ II 2G Ex db eb IIC T6/T5 Gb	Ex db eb IIC T6/T5 Gb
	Dust	⊕ II 2D Ex tb IIIC T80/T95°C Db	Ex tb IIIC T80/T95°C Db
Ex marking of electrical accessories	Gas	⊕ II 2G Ex eb IIC Gb	Ex eb IIC Gb
	Dust	⊕ II 2D Ex tb IIIC Db	Ex tb IIIC Db
Conformity to standards		IEC 60079-0, IEC 60079-1, IEC 60079-7, IEC 60079-31 EN 60079-0, EN 60079-1, EN 60079-7, EN 60079-31	
Material	Signal lamp enclosure	Nylon(PA66), Polycarbonate(PC)	
	Electrical accessories	Nylon(PA66), Polycarbonate(PC)	
Electrical accessories lampshade color		Red	Green, Yellow, Blue, White
Light source color		Red	White
Light source		LED	
Rated voltage		12~36V AC/DC, 48~127V AC/DC, 220~415V AC, 220~250V DC	
Frequency		50Hz/60Hz	
Rated power		36V/0.6W, 127V/1.3W, 415V/3.8W, 250V/1.8W	
Degree of protection		IP66 (After assembly with electrical accessories)	
Electrical accessories weight		21g	
Component weight		Board back type: 75g	
Ambient temperature	Temperature class	Ambient temperature	Gas
		-40°C~+55°C	T6
		-40°C ~ +65°C	T5
Terminal wire diameter		0.75~2.5mm <sup>2</sup>	
Available cable outer diameter		Φ6-Φ11mm, Φ9-Φ13mm	

### 4 Outline Dimension of Electrical Accessories (Dimensions in mm)

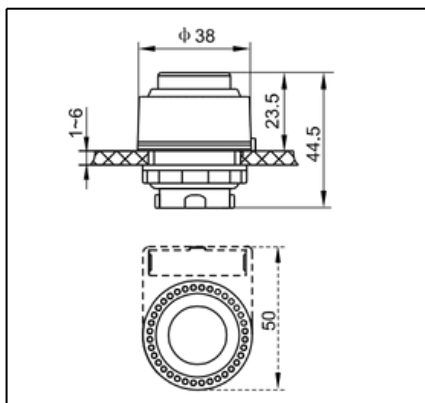

### 5 Component Outline Dimension (Dimensions in mm)

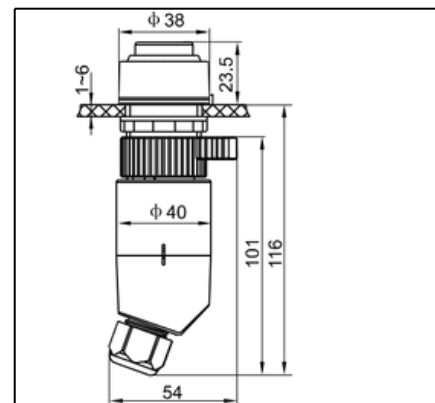

### 6 Installation Distance (Dimensions in mm)

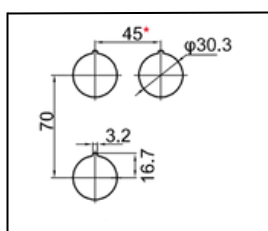

### 7 Schematic Diagram

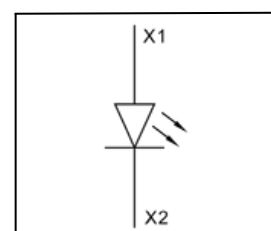

# TL-EX-FH-0105-Series Explosion-proof Switch Button

## 1 Application and Features

- Explosion protection ATEX
- Application in hazardous area Zone 1 and Zone 2 Zone 21 and Zone 22
- 6 operating modes: standard button, emergency stop button with self-locking, mushroom button, knob switch, mushroom button with lock-key, knob switch with key.
- The contact module has a wiping action, has a self-cleaning function of the contact.
- Can add 3-6 sets of modules according to user requirements.
- The contact module and the button head is buckle structure, which is convenient to disassemble and assemble.
- The contact module is able to adjust the angle after assembled, make wiring easy and beautiful.
- Protective cover for emergency stop button (rotate to reset) is optional.
- Product shall be used with flame-proof box.



## 2 Nomenclature

TL-EX-FH-0105- □□ / □□

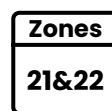
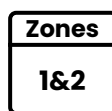
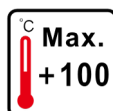
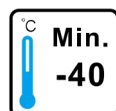
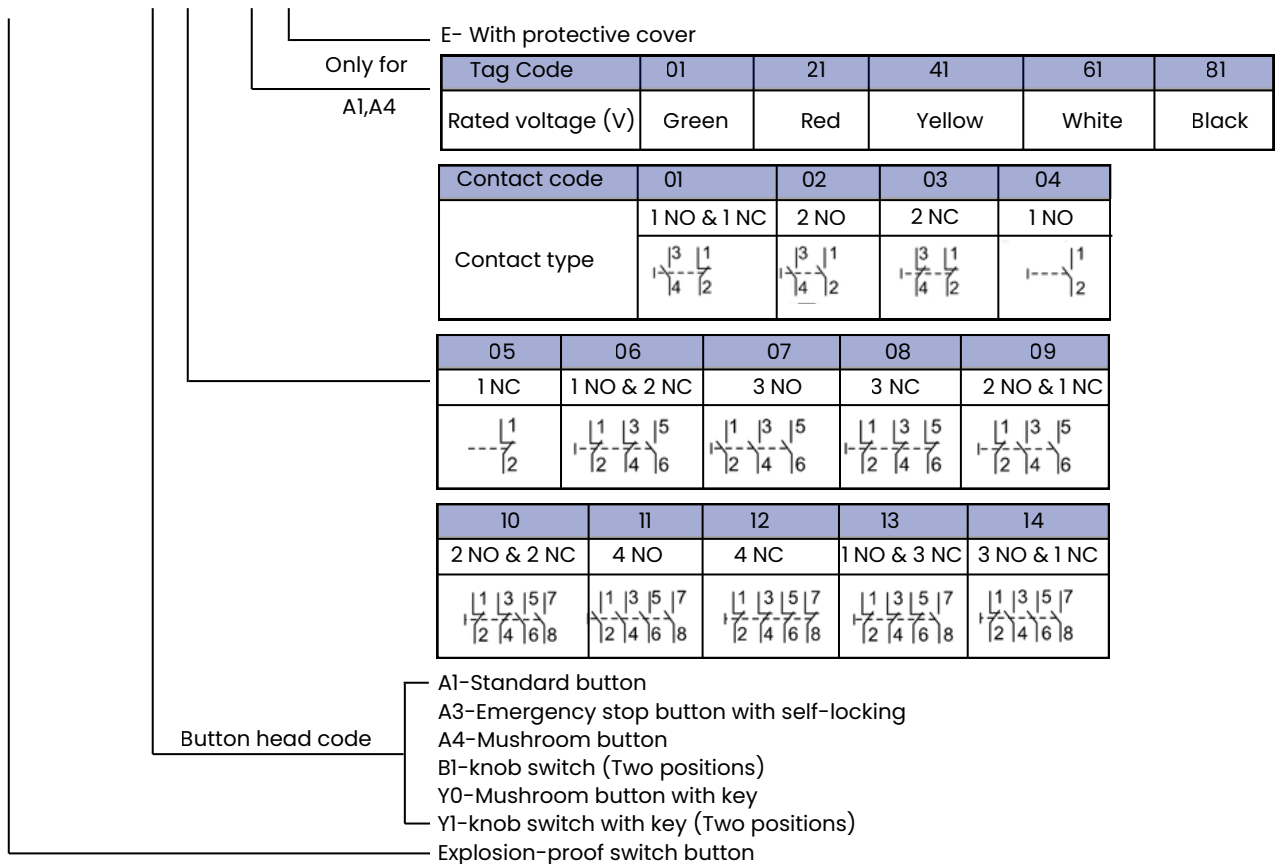

## TL-EX-FH-0105-Series Explosion-proof Switch Button



### 3 Technical Parameter

<b>Ex marking</b>	<b>Gas</b>	⊕ II 2G Ex db IIC Gb	Ex db IIC Gb
	<b>Dust</b>	⊕ II 2D Ex db IIIC Db	Ex db IIIC Db
<b>Conformity to standards</b>	IEC 60079-0, IEC 60079-1, IEC 60079-31 EN 60079-0, EN 60079-1, EN 60079-31		
<b>Enclosure materials</b>	Aluminum alloy		
<b>Rated voltage/current</b>	AC-15: 120V/8A, 1A, 230V/6A, 400V/4A, 690V/2A		
	DC-13: 24V5A, 125V/1.1A, 250V/0.55A		
<b>Rated value</b>	Ui=690V, Ith=10A		
<b>Degree of protection</b>	IP66 (terminal IP20)		
<b>Assembled thread</b>	Flame-proof thread M32x1.5		
<b>Service temperature</b>	-40°C ~+100°C		
<b>Applicable wire diameter of terminal</b>	0.5~2.5mm <sup>2</sup>		
<b>Types</b>	Standard button (A1)	With spring, auto-reset	
	Emergency stop button with self-locking (A3)	Press to lock, rotate to reset	
	Mushroom button (A4)	Mushroom head type, With spring, auto-reset	
	Knob switch (B1)	Two position, 90° rotated angle	
	Mushroom button with key (Y0)	Press to lock, rotate the key to reset	
	Knob switch with key (Y1)	Two position, 90° rotated angle	

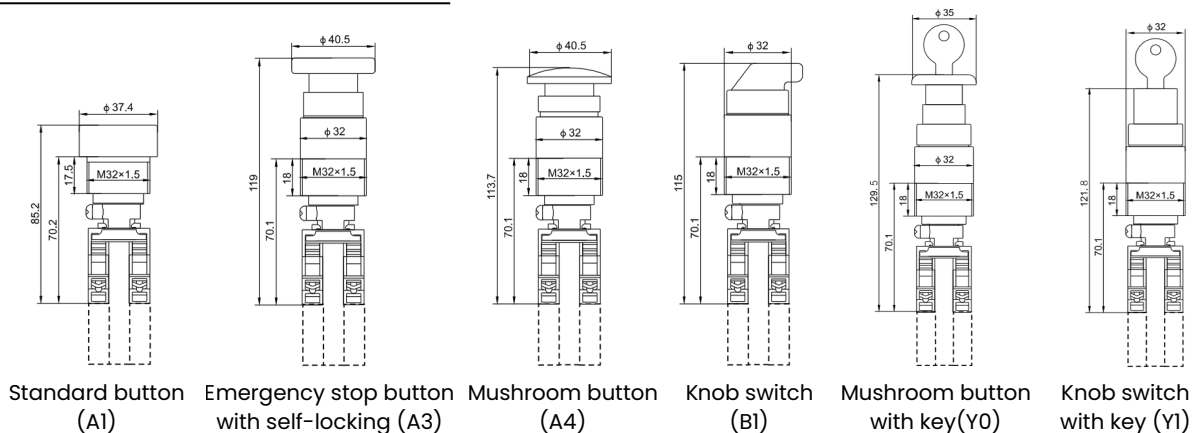
### 4 Outline and Installation Dimension (Dimensions in mm)



### 5 Accessories list

Item	Picture	Material	Size (mm)	Purchase code	Weight (kg)
LHLS-02-18 HL0201-A1 Safety locker		Polycarbonate (PC)	54x56	1.07.291.00018	0.032
LHLS-02-13 HL0201-A3 Safety cover		Nylon (PA66)	48x48	1.07.291.00013	0.014
LHLS-02-14 HL0201-A3 Safety locker		Nylon (PA66)	48x48	1.07.291.00014	0.028

## TL-EX-FH-0105-A Series Explosion-proof Control Button With Signal Lamp

### 1 Application and Features

- Explosion protection ATEX
- Application in hazardous area Zone 1 and Zone 2 Zone 21 and Zone 22
- The contact module has a wiping action, has a self-cleaning function of the contact.
- Can add 3-6 sets of modules according to user requirements.
- The contact module and the button head is buckle structure, which is convenient to disassemble and assemble.
- The contact module is able to adjust the angle after assembled, make wiring easy and beautiful.
- Product shall be used with flame-proof box.



### 2 Nomenclature

TL-EX-FH-0105-A □ □ / □

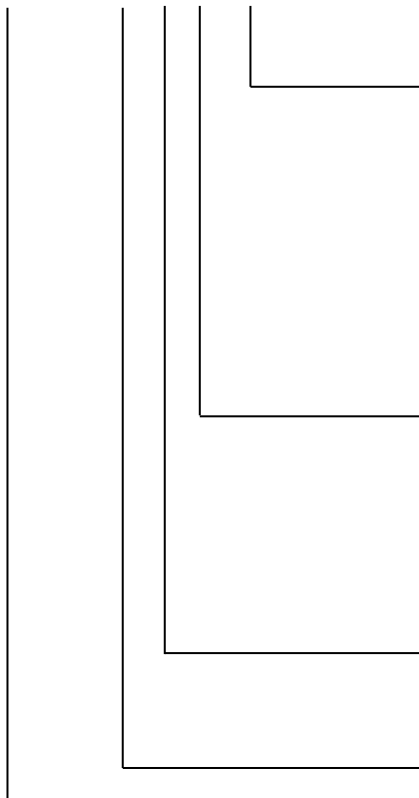

Contact code	01	02	03	04	05
Contact type	1 NO 1 NC	2 NO	2 NC	1 NO	1 NC

Contact code	06	07	08	09	10
Contact type	1 NO 1 NC	3 NO	3 NC	2 NO 1 NC	2 NO 2 NC

Contact code	11	12	13	14
Contact type	4 NO	4 NC	1 NO 3 NC	3 NO 1 NC

Light voltage code	00	01	02
Rated voltage (V)	DC12	AC/DC24	AC/DC48

Light voltage code	03	04	05
Rated voltage (V)	AC/DC60	AC110~130	DC110~130

Light voltage code	06	07	08	09
Rated voltage (V)	DC220	AC230	AC380	AC415

Code	R	G	Y	W	B
Color of light cover	Red	Green	Yellow	White	Blue

Illuminated Control Buttons

Explosion-proof control button with signal lamp

Note: Contacts can be added to 4 sets by requirements

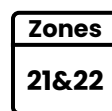
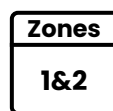
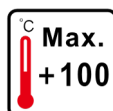
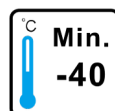

## TL-EX-FH-0105-A Series Explosion-proof Control Button With Signal Lamp

### 3 Technical Parameter

<b>Ex marking</b>	<b>Gas</b>	II 2G Ex db IIC Gb	Ex db IIC Gb
	<b>Dust</b>	II 2D Ex tb IIIC Db	Ex tb IIIC Db
<b>Conformity to standards</b>		IEC 60079-0, IEC 60079-1, IEC 60079-31 EN 60079-0, EN 60079-1, EN 60079-31	
<b>Enclosure material</b>	<b>Body</b>	Aluminum alloy	
	<b>Light cover</b>	Polycarbonate (PC)	
<b>Color of light cover</b>		Red, green, yellow, blue, white	
<b>Contact module</b>		AC-15: 120V/8A, 230V/6A, 400V/4A, 690V/2A	
<b>Rated Capacity</b>		DC-13: 24V/5A, 125V/1.1A, 250V/0.55A	
<b>Rated value of contact module</b>		U <sub>i</sub> =690V, I <sub>th</sub> =10A	
<b>Rated power of light</b>		Maximum 1W	
<b>Rated voltage of light</b>	110~130.230.380.415V AC		
	12, 110~130,220V DC		
	24, 48, 60V AC/DC		
<b>Anti inductive voltage interference indicator light</b>	5.1V(12~60V),		
	15V(110~415V),		
<b>Light source of indicator light</b>		LED	
<b>Frequency</b>		50Hz/60Hz	
<b>Degree of protection</b>		IP66 (terminal IP20)	
<b>Assembled thread</b>		Flame-proof thread M32X1.5	
<b>Service temperature</b>		-40°C ~+100°C	
<b>Applicable wire diameter of terminal</b>		0.5~2.5mm <sup>2</sup>	

### 4 Outline and Installation Dimension (Dimensions in mm)

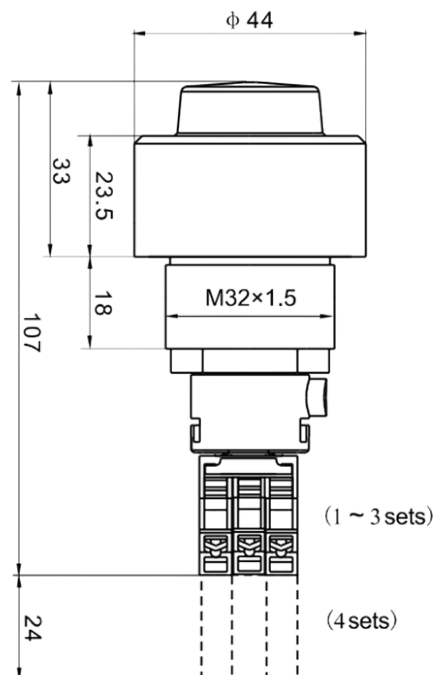

# TL-EX-FH-0105-B1 Series Explosion-proof Switch Button

## 1 Application and Features

- Explosion protection ATEX
- Application in hazardous area Zone 1 and Zone 2 Zone 21 and Zone 22
- The enclosure is made of aluminum alloy or stainless steel.
- The switch contact module has a wiping action, has a self-cleaning function of the contact.
- Can add to 4 sets of modules according to user requirements.
- The switch contact and switch operating head are buckle structure, which is convenient to disassemble and assemble.
- Product shall be used with flame-proof box.



## 2 Nomenclature

TL-EX-FH-0105-B1 □ / □ □

Tag code	01	02	03	04	05	11	12	13	14	15	16	99
Tag mark	0-I	I-II	I-0-II	0-●-I	I-●-0	Off On	Auto Manual	Local Remote	Auto Stop Manual	Stop-Run -Start	Lock Run -Start	Other

Switch code	Contact diagram	Position of knob	Switch code	Contact diagram	Position of knob	Switch code	Contact diagram	Position of knob
01			02			03		
07			08			06		
04			05			15		
18								

Knob switch

Explosion-proof switch button

Note: Switch contacts can be added to 4 sets by requirements

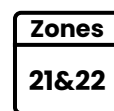
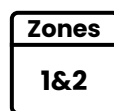
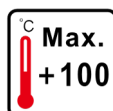
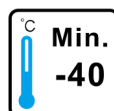

## TL-EX-FH-0105-B1 Series Explosion-proof Switch Button

### 3 Technical Parameter

Ex marking	Gas	⊕ II 2G Ex db IIB Gb	Ex db IIB Gb
		⊕ II 2G Ex db IIC Gb	Ex db IIC Db
	Dust	⊕ II 2D Ex tb IIIC Db	Ex tb IIIC Db
Conformity to standards		IEC 60079-0, IEC 60079-1, IEC 60079-31 EN 60079-0, EN 60079-1, EN 60079-31	
Enclosure material	Body	Aluminum alloy	
	Handle	Nylon (PA66)	
Rated voltage/current		AC-15: 120V/8A, 230V/6A, 400V/4A, 690V/2A DC-13: 24V5A, 125V/1.1A, 250V/0.55A	
Rated value		Ui=690V, Ith=10A	
Degree of protection		IP66 (terminal IP20)	
Assembled thread		Flame-proof thread M32X1.5	
Service temperature		-40°C ~+100°C	
Applicable wire diameter of terminal		0.5~2.5mm <sup>2</sup>	

### 4 Outline and Installation Dimension (Dimensions in mm)

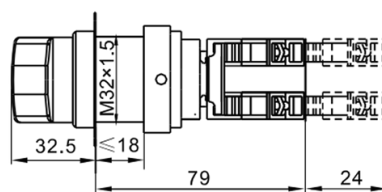
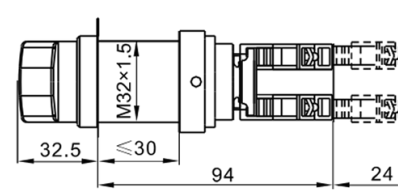
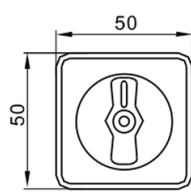
<ul style="list-style-type: none"> <li>TL-EX-FH-0105-B1/□/B (IIB)</li> </ul>  <p>Weight:115kg</p>	<ul style="list-style-type: none"> <li>TL-EX-FH-0105-B1/□/C (IIC)</li> </ul>  <p>Weight:180kg</p>	<ul style="list-style-type: none"> <li>The size of stainless steel handle plate</li> </ul> 
--	---	--

**Note:** It can be used in IIC group atmospheric environment when the volume of enclosure  $\leq 2000\text{cm}^3$ .

## TL-EX-FH-0107-Series Explosion-proof (Signal Lamp)

### 1 Application and Features

- Explosion protection, ATEX
- Application in hazardous area Zone 1 and Zone 2, Zone 21 and Zone 22
- LED indicator light, 5 colors: red, green, yellow, blue, white.



### 2 Nomenclature

TL-EX-FH-0107-

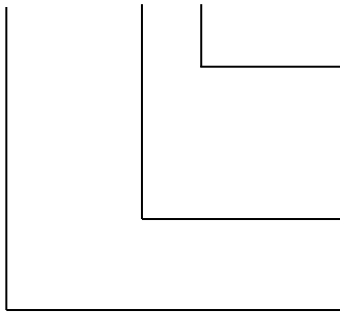

Voltage code	01	02	03	04
Rated voltage (v)	12~36 VAC/DC	48~127 VAC/DC	220~415 VAC	220~250 VDC

Code	R	Y	G	W	B
Color of light cover	Red	Yellow	Green	White	Blue

Explosion-proof signal lamp

### 3 Technical Parameter

<b>Ex marking</b>	<b>Gas</b>	Ex II 2G Ex db eb IIC Gb	Ex db eb IIC Gb
	<b>Dust</b>	Ex II 2D Ex tb IIIC Db	Ex tb IIIC Db
<b>Conformity to standards</b>	IEC60079-0, IEC60079-1, IEC60079-7, IEC60079-31 EN60079-0, EN60079-1, EN60079-7, EN60079-31		
<b>Enclosure materials</b>	Body	Aluminum alloy	
	Light cover	Polycarbonate (PC)	
<b>The color of light cover</b>	Red, green, yellow, blue, white		
<b>Led color</b>	Red, white		
<b>Light source</b>	LED		
<b>Rated Voltage</b>	12~36V AC/DC, 48~127V AC/DC, 220~415V AC, 220~250V DC		
<b>Frequency</b>	50Hz / 60Hz		
<b>Rated power</b>	380V/3.8W, 220V/1.8W, 127V/1.3W, 36V/0.6W		
<b>Degree of protection</b>	IP66 (terminal IP20)		
<b>Assembled thread</b>	Flame-proof thread M32X1.5		
<b>Service temperature</b>	-40°C~+100°C		
<b>Applicable wire diameter of terminal</b>	0.75~2.5mm <sup>2</sup>		
<b>Weight</b>	80g		

### 4 Outline and Installation Dimension (Dimensions in mm)

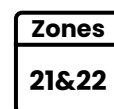
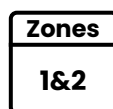
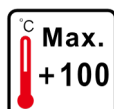
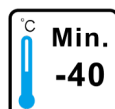
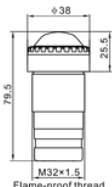

## TL-EX-FH-0109 Series Explosion-proof Ammeters

### 1 Application and Features

- Explosion protection  
ATEX
- Application in hazardous area  
Zone 1 and Zone 2
- Quick comparison of measured and set values
- Two specifications of ammeter: 48 type and 72 type



### 2 Nomenclature

TL-EX-FH-0109- □ □ (□ □ □)

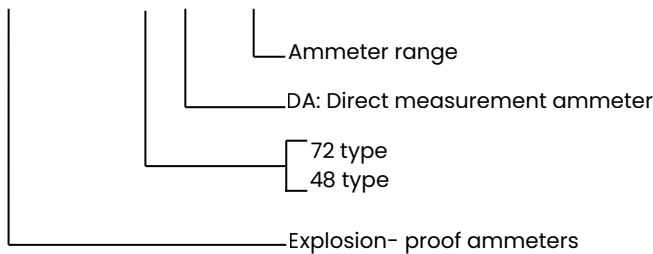

TL-EX-FH-0109- □ □ □ / □

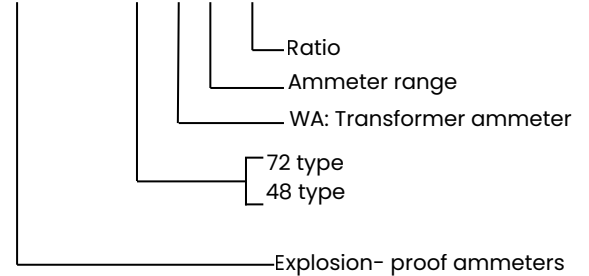

### 3 Technical parameters

<b>Ex marking of ammeter</b>	<b>Gas</b>	⊕ Ex II 2G Ex eb IIC Gb	Ex eb IIC Gb	Ex eb IIC Gb	
<b>Ex marking of electrical accessories</b>	<b>Gas</b>	⊕ Ex II 2G Ex eb IIC Gb	Ex eb IIC Gb	Ex eb IIC Gb	
	<b>Dust</b>	⊕ Ex II 2D Ex tb IIIC Db	Ex tb IIIC Db	Ex tD A21 IP66	
<b>Conformity to standards</b>	IEC 60079-0, IEC 60079-1, IEC 60079-7, IEC 60079-31 EN 60079-0, EN 60079-1, EN 60079-7, EN 60079-31				
<b>Material</b>	Ammeter enclosure	Polycarbonate (PC)			
	Electrical accessories	Nylon (PA66), tempered glass			
<b>Insulation voltage</b>	690V AC				
<b>Frequency</b>	50Hz/60Hz				
<b>Accuracy grade</b>	1.5 class				
<b>Overload multiples</b>	5 times				
<b>Technical parameters</b>	Type	Structure	Overload multiples	Rated current	Measurement range
	48DA	Direct measurement	5	1A	0-1A
				5A	0-5A
				10A	0-10A
	48WA	With current transformer	X/1A X/5A	1A	1A, 2.5A, 5A, 10A, 15A, 20A, 25A, 30A, 40A, 50A, 60A, 75A, 100A, 150A, 200A, 250A, 300A, 400A, 500A, 600A, 700A, 800A, 1000A
				5A	1000A
72DA	Direct measurement	5	1A	0-1A	
			5A	0-5A	
72WA	With current transformer	X/1A X/5A	1A	1A, 2.5A, 5A, 10A, 15A, 20A, 25A, 30A, 40A, 50A, 60A, 75A, 100A, 150A, 200A, 250A, 300A, 400A, 500A, 600A, 700A, 800A, 1000A	
			5A	1000A	
<b>Ambient temperature</b>	-25°C ~ +80°C, -45°C ~ +80°C				
<b>Terminal wire diameter</b>	2.5mm <sup>2</sup>				
<b>Weight</b>	48 type ammeter: 78g, 48 type Electrical accessories (including glass): 38g 72 type ammeter: 118g, 72 type Electrical accessories (including glass): 53g				

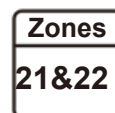
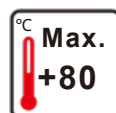

## TL-EX-FH-0109 Series Explosion-proof Ammeters

### 4 Outline and Installation Dimension (Dimensions in mm)

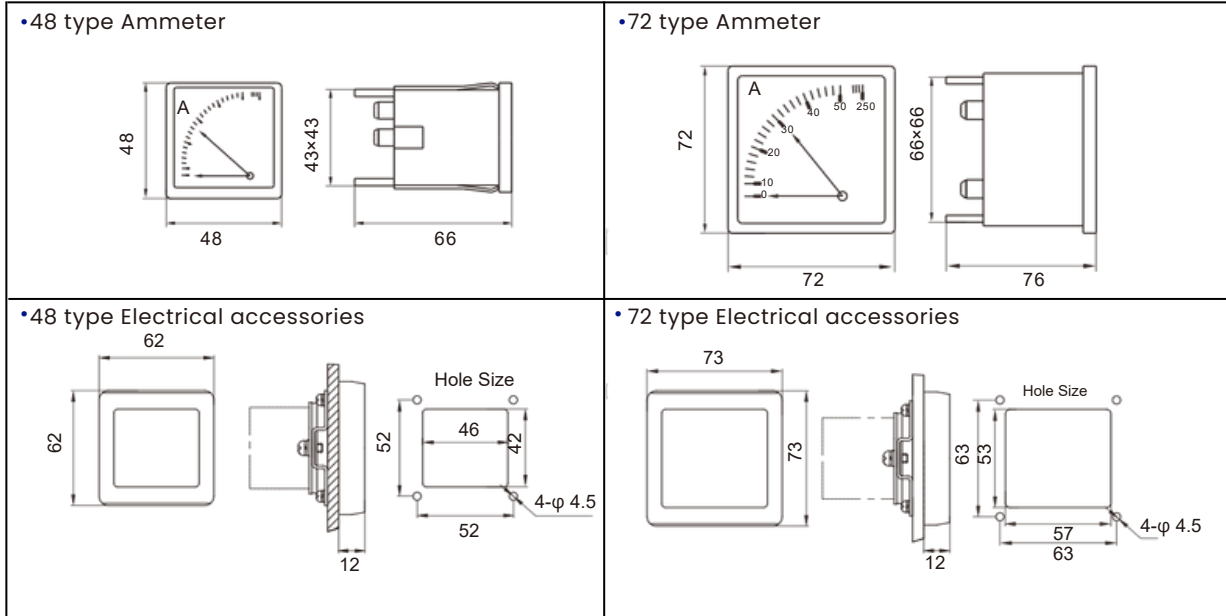

## TL-EX-FH-0160-Series Explosion-proof Anticorrosive Moulded Case Circuit Breaker

### 1 Application and Features

- Explosion protection ATEX
- Application in hazardous area Zone 1 & 2
- GRP (Polyester resin, glass-fibre reinforced) enclosure.
- The enclosure is equipped with terminal contact.

### 2 Nomenclature

TL-EX-FH-0160 - □ / □ / □

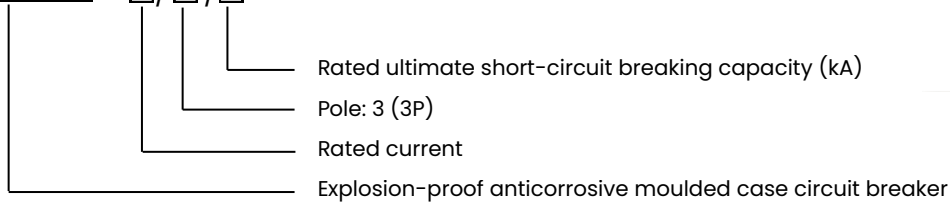

### 3 Technical Parameter

Ex marking	Gas	Ex db eb IIC Gb
<b>Conformity to standards</b>		IEC 60079-0, IEC 60079-1, IEC 60079-7 EN 60079-0, EN 60079-1, EN 60079-7
<b>Enclosure material</b>		GRP (Polyester resin, glass fibre reinforced)
<b>Enclosure color</b>		Black
<b>Rated voltage</b>		Max. AC 690V DC 250V, DC 500V, DC 750V
<b>Rated current</b>		100A, 125A, 160A, 200A, 250A
<b>Tripping rated current</b>		16A, 25A, 32A, 40A, 50A, 63A, 80A, 100A, 125A, 160A, 200A, 250A
<b>Rated ultimate short-circuit breaking capacity</b>		25kA, 36kA, 50kA, 70kA, 100kA, 150kA
<b>Frequency</b>		50Hz / 60Hz
<b>Terminal section</b>		2×70mm <sup>2</sup> , 2×95mm <sup>2</sup> , 2×120mm <sup>2</sup>
<b>Ambient temperature</b>		-40°C ~ +60°C
<b>Operating temperature</b>		-40°C ~ +100°C

### 4 Outline and Installation Dimension (Dimensions in mm)

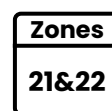
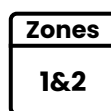
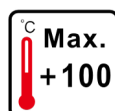
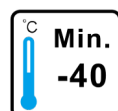
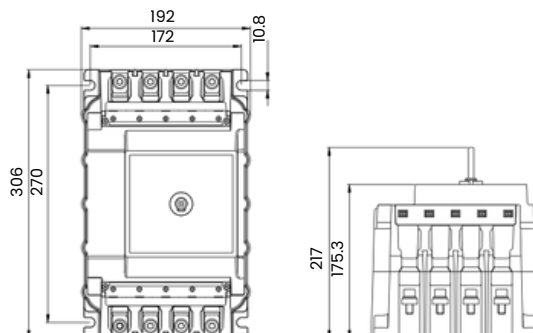

# TL-EX-FH-0161-Series Explosion-proof Anticorrosive Moulded Case Circuit Breaker

## 1 Application and Features

- Explosion protection
- Application in hazardous area Zone 1 & 2
- GRP (Polyester resin, glass fibre reinforced) enclosure.
- It is equipped with Schneider iC65 series, Chint NXB-63 series, and other MCB miniature circuit breakers, and has a special operating mechanism inside.
- The enclosure is equipped with main terminal contact, electrical accessory contact, and operation device.
- There are 7 kinds of electrical accessories.



## 2 Nomenclature

TL-EX-FH-0160 - □ / □ / □ / □ - □

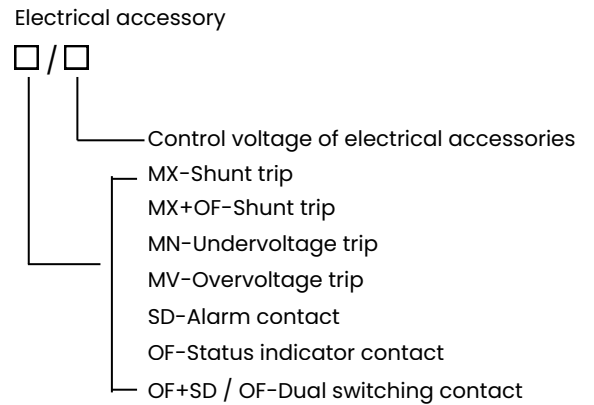
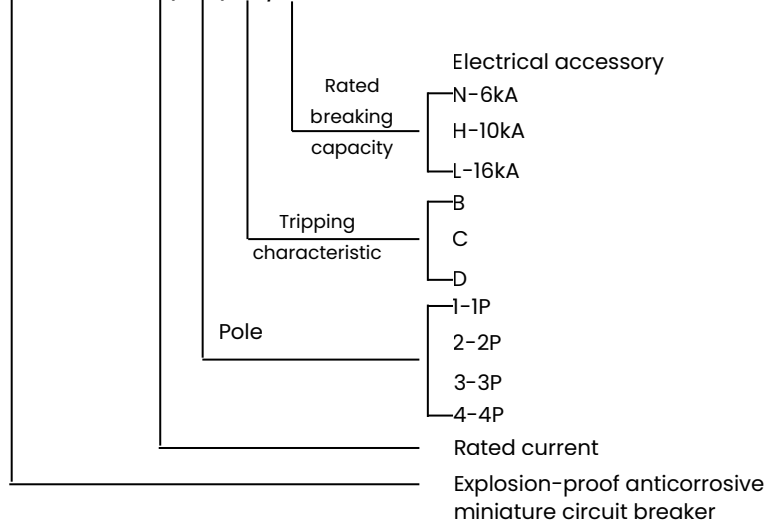

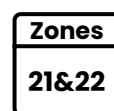
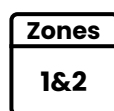
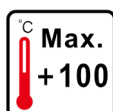
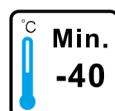

## 3 Technical Parameter

Ex marking	Gas	Ex db eb IIC Gb
<b>Conformity to standards</b>		IEC 60079-0, IEC 60079-1, IEC 60079-7 EN 60079-0, EN 60079-1, EN 60079-7
<b>Enclosure material</b>		GRP (Polyester resin, glass fibre reinforced)
<b>Enclosure color</b>		Black
<b>Rated voltage</b>		AC12-133V, AC220-240V, AC380-415V, AC440V DC60V, DC110V, DC125V, DC220V, DC250V, DC400V, DC440V, DC500V
<b>Rated current</b>		16A, 25A, 32A, 63A, 80A
<b>Tripping rated current</b>		16A, 25A, 32A, 40A, 50A, 63A, 80A, 100A, 125A, 160A, 200A, 250A
<b>Rated breaking capacity</b>		6kA, 10kA, 16kA
<b>Pole</b>		1P, 2P, 3P, 4P
<b>Tripping characteristics</b>		B, C, D
<b>Contact capacity of electrical accessories</b>		AC-13 3A / 250V
		AC-15 2A / 250V
<b>Terminal section</b>	<b>Main contact</b>	2×10mm <sup>2</sup> (<40A), 2×16mm <sup>2</sup> (<80A)
	<b>Electrical accessory contact</b>	2×2.5mm <sup>2</sup>
<b>Operating temperature</b>		-40°C ~ +100°C



## TL-EX-FH-0161-Series Explosion-proof Anticorrosive Miniature Circuit Breaker

### 4 Selection Table

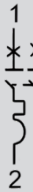
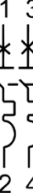
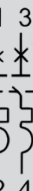
	Pole	Tripping characteristic	Rated current (A)	Rated voltage (V)	Terminal section (mm <sup>2</sup> )	Electrical schematic diagram	Weight (kg)	Electrical accessory parameter
	1P	B/C/D	16	AC	2x10 (≤40A)		0.9	Electrical accessory contact capacity
				12-133				
				AC				
				220-240				
	2P			AC	2x16 (≤80A)		1.3	AC-13 3A/250V AC-15 2A/250V
				380-415				
				AC 440				
				DC 60				
	3P			DC 110	2x16 (≤80A)		1.7	Electrical accessory contact terminal section 2x2.5mm <sup>2</sup>
				DC 125				
				DC 220				
				DC 250				
	4P			DC 400	2x16 (≤80A)		2.0	
				DC 440				
				DC 500				

### 5 Electrical Accessory

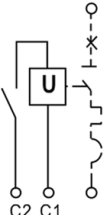
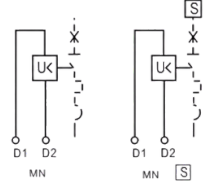
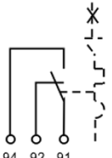
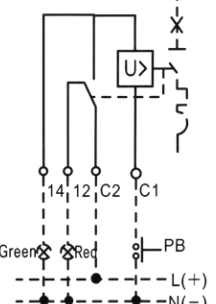
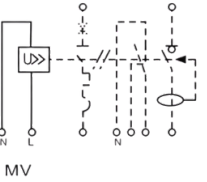
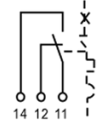
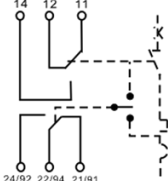
Type	Control voltage		Type	Control voltage		Type
	(VAC)	(VDC)		(VAC)	(VDC)	
<b>MX Shunt trip until</b> 	110...415	110...130	<b>MN Undervoltage trip unit instantaneous trip MN Delayed trip</b> 	220...240	-	<b>SD Alarm contact</b> 
	48	48		48	48	
	12/24	12/24		220...240	-	
<b>MX+OF Shunt trip unit</b> 	110...415	110...130	<b>MV Undervoltage trip unit</b> 	230	-	<b>OF Status indicator contact</b> 
	48	48				
	12/24	12/24				
						<b>OF+SD/OF Dual switch contact</b> 

## TL-EX-FH-0161-Series Explosion-proof Anticorrosive Miniature Circuit Breaker

### 6 Outline and Installation Dimension (Dimensions in mm)

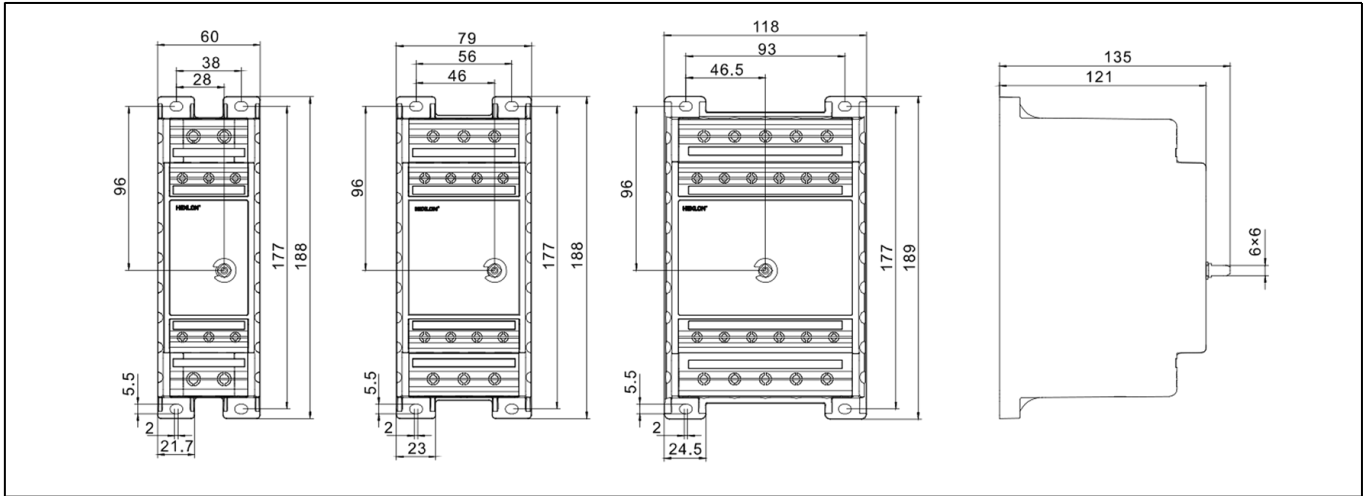

Size (mm)	Pole
Size 1	1P , 2P
Size 2	3P , 2P + Electrical accessory

Size (mm)	Pole
Size 3	4P , 3P + Electrical accessory
-	-

# TL-EX-FH-0161-L Series Explosion-proof Anticorrosive Residual Current Operated Circuit Breakers

## 1 Application and Features

- Explosion protection
- ATEX  
Application in hazardous area  
Zone 1 and Zone 2
- GRP (Polyester resin, glass fibre reinforced) enclosure.
- It is equipped with small leakage circuit breakers from Schneider, Chint and other brands, and has a dedicated operating mechanism inside.
- The enclosure is equipped with main terminal contact, electrical accessory contact and operation device.
- There are 7 kinds of electrical accessories.
- The product should be used in conjunction with the increased safety type enclosure and must not be used alone.



## 2 Nomenclature

TL-EX-FH-0161-L □/□/□/□/□-□

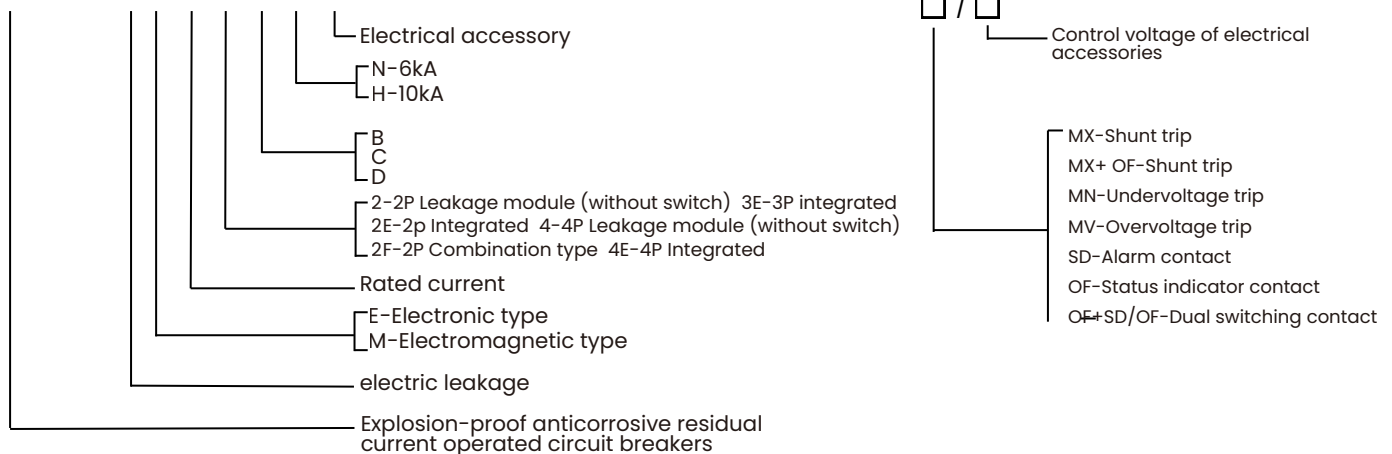

## 3 Technical parameters



Ex marking	Gas	Ex db eb IIC Gb
Conformity to standards		IEC 60079-0, IEC 60079-1, IEC 60079-7 EN 60079-0, EN 60079-1, EN 60079-7
Enclosure material		GRP (Polyester resin, glass fibre reinforced)
Enclosure color		Black
Rated voltage		100~133V AC, 220~250V AC, 380~415V AC
Rated current		16A, 25A, 32A, 63A
Rated residual action current		10mA, 30mA, 50mA, 75mA, 100mA, 300mA, 500mA
Rated breaking capacity		6kA, 10kA
Pole		2P, 4P, 2E, 3E, 4E, 2F
Tripping characteristics		B, C, D
Terminal section	Main contact	2X10mm (≤40A), 2X16mm (≤63A)
	Electrical accessory contact	2X2.5mm
Ambient temperature		-40°C~+100°C

# TL-EX-FH-0161-L Series Explosion-proof Anticorrosive Residual Current Operated Circuit Breakers

## 4 Selection Table

Pictorial view	Pole	Tripping characteristic	Rated current (A)	Rated voltage (V)	Terminal section (mm <sup>2</sup> )	Electrical schematic diagram	Weight (kg)	Electrical accessory parameter
	2P	B/C/D	16 25 32 63	AC 100-133 AC 220-240 AC 380-415	2×10 (≤40A)	2P Electronic type	20	Electrical accessory contact terminal section 2X2.5mm <sup>2</sup>
						2P Electromagnetic type	20	
	3P					3P Electronic type	28	
						3P Electromagnetic type	28	
	4P					4P Electronic type	30	
						4P Electromagnetic type	30	

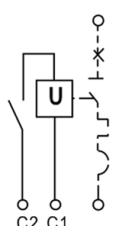
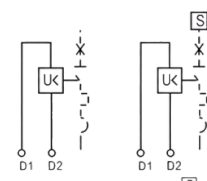
## 5 Electrical Accessory

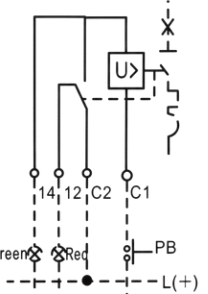
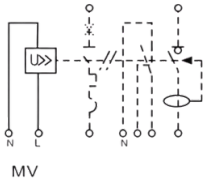
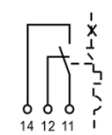
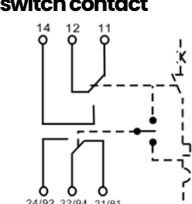
Type	Control voltage		Type	Control voltage		Type
	(VAC)	(VDC)		(VAC)	(VDC)	
<b>MX Shunt trip until</b> 	110...415	110...130	<b>MN Undervoltage trip unit</b> <b>instantaneous trip MN</b> <b>Delayed trip</b> 	220...240	-	<b>SD Alarm contact</b> 
	48	48		48	48	
	12/24	12/24		220...240	-	
<b>MX+OF Shunt trip unit</b> 	110...415	110...130	<b>MV Undervoltage trip unit</b> 	230	-	<b>OF Status indicator contact</b> 
	48	48		<b>OF+SD/OF Dual switch contact</b> 		
	12/24	12/24				

## TL-EX-FH-0161-L Series Explosion-proof Anticorrosive Residual Current Operated Circuit Breakers

### 6 Outline and Installation Dimension (Dimensions in mm)

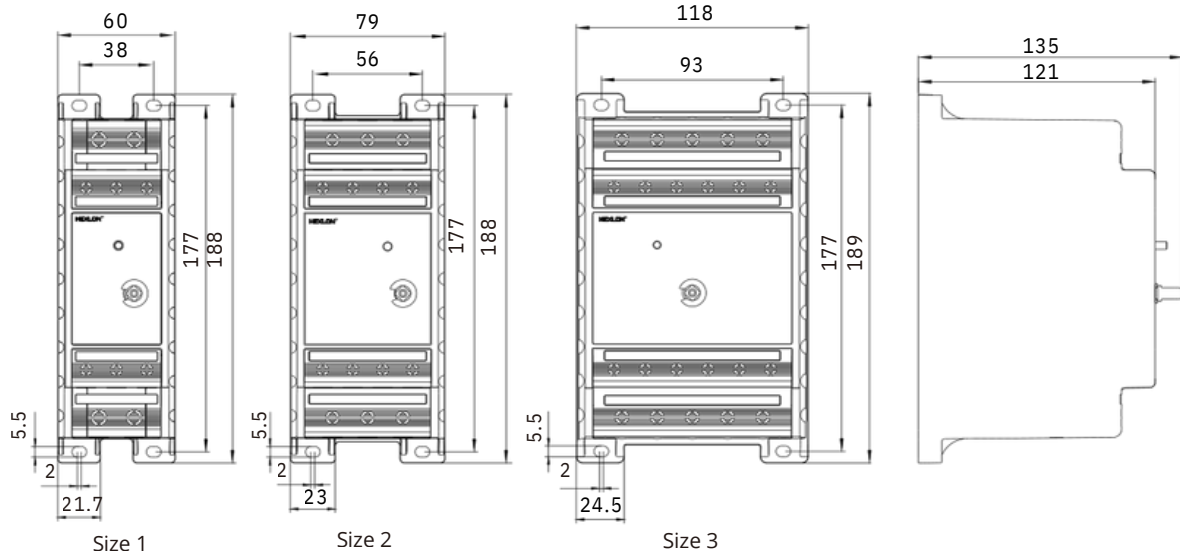

Size (mm)	Pole
Size 1	2P Integrated, 2P Leakage module
Size 2	2P Integrated+Electrical Accessory, 2P Leakage module+Electrical Accessory
Size 3	2P Combination type, 2P Combination type+Electrical Accessory, 2P Integrated+Electrical Accessory, 3P Integrated+Electrical Accessory, 3P Integrated, 4P Integrated, 4P Leakage module, 4P Leakage module+Electrical Accessory

## TL-EX-FH-0173- Series Explosion-proof Anticorrosive Surge Protector

### 1 Application and Features

- Explosion protection
- Application in hazardous area  
Zone 1 and Zone 2
- GRP (Polyester resin,glass fibre reinforced) enclosure,built-in surge protective device.
- The enclosure is equipped with terminal contact.



### 2 Nomenclature

TL-EX-FH-0173-

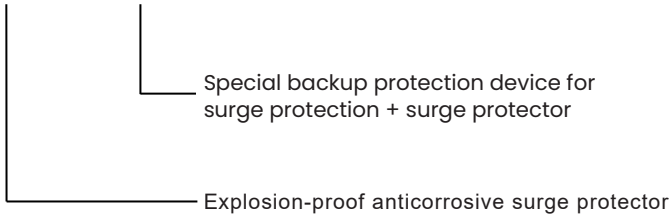

### 3 Technical parameters

Ex marking	Gas	Ex db eb IIC Gb
Enclosure material		GRP (Polyester resin,glass fibre reinforced)
Enclosure color		Black
Rated voltage		AC 400V/230V
Maximum surge current		25KA
Ambient temperature		-40°C~+100°C

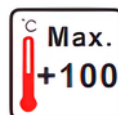

## TL-EX-RT-XX-Series Explosion-proof Blind Plug

### 1 Application and Features

- Explosion protection  
ATEX
- Application in hazardous area  
Zone 1 and Zone 2,  
Zone 21 and Zone 22
- Explosion protection types  
II 2G Ex db IIC Gb  
II 2D Ex tb IIIC Db
- Used to close unused threaded entries in explosion-proof enclosures and equipment.
- Ensures flameproof protection is maintained in hazardous environments.
- Suitable for Gas, NPT and Metric thread types.
- Provides IP66 / IP67 ingress protection when installed correctly.
- Manufactured from special aluminium alloy, stainless steel or nickel-plated brass.
- Designed for reliable sealing and mechanical strength.
- Available in a wide range of thread sizes for different enclosure applications.



### 2 Technical parameters

TL-EX-RT-XX	X1	Usage type
	G	Gas Code
	N	NPT Code
	M	Metric Code

### 3 Selection Table

Gas Code	NPT Code	QA ( Inch )	Metric Code	QA ( mm )
TL-EX-RT-G1	TL-EX-RT-N1	3/8"	TL-EX-RT-M1	M12 x 1,5
TL-EX-RT-G2	TL-EX-RT-N2	3/8"	TL-EX-RT-M2	M14 x 1,5
TL-EX-RT-G3	TL-EX-RT-N3	1/2"	TL-EX-RT-M3	M14 x 1,5
TL-EX-RT-G4	TL-EX-RT-N4	3/4"	TL-EX-RT-M4	M20 x 1,5
TL-EX-RT-G5	TL-EX-RT-N5	1"	TL-EX-RT-M5	M25 x 1,5
TL-EX-RT-G6	TL-EX-RT-N6	1 1/4"	TL-EX-RT-M6	M30 x 1,5
TL-EX-RT-G7	TL-EX-RT-N7	1 1/2"	TL-EX-RT-M7	M32 x 1,5
TL-EX-RT-G8	TL-EX-RT-N8	1 3/4"		
TL-EX-RT-G9	TL-EX-RT-N9	2"		
TL-EX-RT-G10	TL-EX-RT-N10	2 1/2"		
TL-EX-RT-G11	TL-EX-RT-N11	3"		

## TL-EX-KP-XX Series Explosion-proof Couplings

### 1 Application and Features

- Explosion protection  
ATEX
- Application in hazardous area  
Zone 1 and Zone 2,  
Zone 21 and Zone 22
- Explosion protection types  
II 2G Ex db IIC Gb  
II 2D Ex tb IIIC Db
- Used for connecting two threaded conduit sections in hazardous area installations.
- Suitable for Gas, NPT and Metric threaded conduit systems.
- Maintains explosion-proof integrity between connected conduit components.
- Manufactured from galvanized carbon steel for mechanical strength and corrosion resistance.
- Provides secure conduit extension while maintaining flameproof protection.
- Available in multiple thread sizes and lengths to suit installation requirements.
- Designed for industrial environments including oil, gas and chemical plants.



### 2 Technical parameters

TL-EX-KP-XX	XI	Usage type
	G	Gas Code
	N	NPT Code
	M	Metric Code

### 3 Selection Table

Gas Code	NPT Code	QA ( Inch )	Metric Code	QA ( mm )
TL-EX-RT-G1	TL-EX-RT-N1	3/8"	TL-EX-RT-M1	M12 x 1,5
TL-EX-RT-G2	TL-EX-RT-N2	3/8"	TL-EX-RT-M2	M14 x 1,5
TL-EX-RT-G3	TL-EX-RT-N3	1/2"	TL-EX-RT-M3	M14 x 1,5
TL-EX-RT-G4	TL-EX-RT-N4	3/4"	TL-EX-RT-M4	M20 x 1,5
TL-EX-RT-G5	TL-EX-RT-N5	1"	TL-EX-RT-M5	M25 x 1,5
TL-EX-RT-G6	TL-EX-RT-N6	1 1/4"	TL-EX-RT-M6	M30 x 1,5
TL-EX-RT-G7	TL-EX-RT-N7	1 1/2"	TL-EX-RT-M7	M32 x 1,5
TL-EX-RT-G8	TL-EX-RT-N8	1 3/4"		
TL-EX-RT-G9	TL-EX-RT-N9	2"		
TL-EX-RT-G10	TL-EX-RT-N10	2 1/2"		
TL-EX-RT-G11	TL-EX-RT-N11	3"		

## TL-EX-R-X1-X2-X3 Series Explosion-proof Reduction Fittings

### 1 Application and Features

- Explosion protection ATEX
- Application in hazardous area Zone 1 and Zone 2, Zone 21 and Zone 22
- Explosion protection types II 2G Ex db IIC Gb II 2D Ex tb IIIC Db
- It is designed to connect pipe or cable entries with different thread sizes.
- Suitable for gas and dust hazardous environments requiring certified explosion protection.
- Maintains flameproof integrity when connecting equipment with different thread sizes.
- Available with Gas (G), NPT and Metric thread configurations.
- Manufactured from special aluminium alloy, stainless steel or nickel-plated brass depending on model.
- IP66 / IP67 protection when properly installed.
- Thread combinations available for Gas-Gas, Gas-NPT, Metric-NPT and Metric-Gas connections.
- Wide range of male and female thread sizes available for flexible installation.



### 2 Technical parameters

TL-EX-R-X1-X2-X3	X1	Usage type
	G	Gas Code
	N	NPT Code
	M	Metric Code

### 3 Selection Table

X1 : TYPE ( THREAD )		X2 ( Male and Female Size )	X3 : Male and Female Size
G	GAS	$\frac{1}{4}$ " - $\frac{3}{8}$ " - $\frac{1}{2}$ " - $\frac{3}{4}$ " - 1" 1 $\frac{1}{4}$ " - 1 $\frac{1}{2}$ " - 1 $\frac{3}{4}$ " - 2"	$\frac{1}{4}$ " - $\frac{3}{8}$ " - $\frac{1}{2}$ " - $\frac{3}{4}$ " - 1" - 1 $\frac{1}{4}$ " 1 $\frac{1}{2}$ " - 1 $\frac{3}{4}$ " - 2"
N	NPT		
M	METRIC		
GN	GAS - NPT	M12x1,5 - M14 x 1,5 - M20x1,5 M25x1,5 - M30 x 1,5 - M32x1,5 M40x1,5 - M50x1,5	M12x1,5 - M14 x 1,5 - M20x1,5 M25x1,5 - M30 x 1,5 - M32x1,5 M40x1,5 - M50x1,5
NG	NPT - GAS		
NM	NPT-METRIC		
MN	METRIC- NPT		
GM	GAS-METRIC		
MG	METRIC - GAS		

## TL-EX-NP-XX Series Explosion-proof Nipple Fittings

### 1 Application and Features

- Explosion protection  
ATEX
- Application in hazardous area  
Zone 1 and Zone 2,  
Zone 21 and Zone 22
- Explosion protection types  
II 2G Ex db IIC Gb  
II 2D Ex tb IIIC Db
- Designed to provide a male-to-male threaded connection between explosion-proof enclosures, cable glands or conduit systems.
- Suitable for use in hazardous areas where explosive gas and dust atmospheres may be present.
- Maintains the flameproof integrity of Ex d enclosures when correctly installed.
- Typically manufactured with identical male threads on both sides for direct connection of equipment with the same thread size.
- Available with Gas (G), NPT or Metric thread types depending on application requirements.
- Produced from nickel-plated brass, stainless steel or aluminium alloy to ensure corrosion resistance and mechanical strength.
- Designed for use in oil & gas, petrochemical plants, offshore platforms and other hazardous industrial environments.
- Provides IP66 / IP67 protection rating when installed with certified explosion-proof equipment.



### 2 Technical parameters

TL-EX-NP-XX	XI	Usage type
	G	Gas Code
	N	NPT Code
	M	Metric Code

### 3 Selection Table

Gas Code	NPT Code	QA (Inch)	Length (min-max mm)	Metric Code	Size (mm)	Length (min-max mm)
TL-EX-NP-1G	TL-EX-NP-1N	1/2"	45-55	TL-EX-NP-1M	M12 x 1,5	45-55
TL-EX-NP-2G	TL-EX-NP-2N	1/4"	45-55	TL-EX-NP-2M	M14 x 1,5	45-55
TL-EX-NP-3G	TL-EX-NP-3N	3/4"	45-55	TL-EX-NP-3M	M16 x 1,5	45-55
TL-EX-NP-4G	TL-EX-NP-4N	1"	60-70	TL-EX-NP-4M	M20 x 1,5	45-55
TL-EX-NP-5G	TL-EX-NP-5N	1 1/4"	50-60	TL-EX-NP-5M	M25 x 1,5	60-70
TL-EX-NP-6G	TL-EX-NP-6N	1 1/2"	50-60	TL-EX-NP-6M	M30 x 1,5	50-60
TL-EX-NP-7G	TL-EX-NP-7N	2"	50-60	TL-EX-NP-7M	M32 x 1,5	50-60
TL-EX-NP-8G	TL-EX-NP-8N	2 1/2"	70-80			
TL-EX-NP-9G	TL-EX-NP-9N	3"	70-80			

## TL-EX-ST-XX Series Explosion-proof Sealing Fittings

### 1 Application and Features

- Explosion protection ATEX
- Application in hazardous area Zone 1 and Zone 2, Zone 21 and Zone 22
- Explosion protection types  
II 2G Ex db IIC Gb  
II 2D Ex tb IIIC Db
- Designed to prevent the propagation of flame, gas and hot gases through conduit systems in hazardous areas.
- Used to maintain the flameproof integrity of Ex d electrical installations.
- Suitable for installation in hazardous areas where explosive gas and dust atmospheres may occur.
- Allows the installation of sealing compound to form a flameproof barrier inside the conduit system.
- Ensures safe separation between hazardous and non-hazardous areas in electrical conduit installations.
- Manufactured from special aluminium alloy providing high mechanical strength and corrosion resistance.
- Designed for use in oil & gas plants, petrochemical facilities, offshore platforms and other hazardous industrial environments.
- Complies with IEC / EN 60079 standards for explosion protection.



### 2 Technical parameters

TL-EX-ST-XX	XI	Usage type
	G	Gas Code
	N	NPT Code
	M	Metric Code

### 3 Selection Table

Gas Code	NPT Code	QA ( Inch )	Metric Code	QA ( mm )
TL-EX-ST-1G	TL-EX-ST-1N	¼"	TL-EX-ST-1M	M16 x 1,5
TL-EX-ST-2G	TL-EX-ST-2N	½"	TL-EX-ST-2M	M20 x 1,5
TL-EX-ST-3G	TL-EX-ST-3N	¾"	TL-EX-ST-3M	M25 x 1,5
TL-EX-ST-4G	TL-EX-ST-4N	1"	TL-EX-ST-4M	M30 x 1,5
TL-EX-ST-5G	TL-EX-ST-5N	1 ¼"	TL-EX-ST-5M	M32 x 1,5
TL-EX-ST-6G	TL-EX-ST-6N	1 ½"		
TL-EX-ST-7G	TL-EX-ST-7N	1 ¾"		

## TL-EX-JBI-X-X-X Series Explosion-proof Electric Junction Box

### 1 Application and Features

- Explosion protection ATEX
- Application in hazardous area Zone 1 and Zone 2, Zone 21 and Zone 22
- Explosion protection types II 2G Ex db IIC T6 Gb II 2D Ex tb IIIC T85°C Db
- Designed for safe connection and distribution of electrical wiring in hazardous areas.
- Suitable for use in Zone 1 and Zone 21 hazardous locations where explosive gas or dust atmospheres may be present.
- Provides flameproof protection (Ex d) to prevent ignition of surrounding hazardous atmospheres.
- Allows safe cable entry and wiring connections inside the enclosure.
- Manufactured from special aluminium alloy providing high mechanical strength and corrosion resistance.
- Multiple threaded cable entries available to accommodate different installation requirements.
- Designed for use in oil & gas, petrochemical plants, offshore platforms and other hazardous industrial environments.
- Provides IP66 protection against dust and water ingress when properly installed.
- Complies with ATEX Directive 2014/34/EU and IEC / EN 60079 explosion protection standards.



### 2 Technical parameters

Voltage	12 Vac – 450 Vac
Degree of Protection	IP66
Ambient Temperature	-20°C to +50°C
Frequency	50/60 Hz

### 3 Selection Table

TYPE	X (Number Of Connections)	X (Screw Thread Type)	X (Screw Thread Size)
TL-EX-JBI-X-X-X	2	G (Gas Thread)	G ¼", G ½", G ¾", G 1", G 1½"
	3	N (NPT Thread)	NPT ¼", NPT ½", NPT ¾", NPT 1", NPT 1½"
	4	M (Metric Thread)	M16X1,5 ; M20X1,5 ; M25X1,5 ; M30X1,5 ; M32X1,5

## TL-EX-ACGX Series Explosion-proof Cable Glands

### 1 Application and Features

- Explosion protection ATEX
- Application in hazardous area Zone 1 and Zone 2, Zone 21 and Zone 22
- Explosion protection types II 2G Ex db IIC Gb II 2D Ex tb IIIC Db
- Designed for termination of armoured cables in explosion-proof equipment.
- Provides reliable cable retention, sealing and mechanical protection.
- Suitable for hazardous environments where flameproof integrity must be maintained.
- Available for various cable diameters and thread types including NPT, Gas and Metric.
- Multiple sealing components ensure secure clamping of cable armour and inner sheath.
- Provides IP67 ingress protection when installed correctly.
- Manufactured from corrosion-resistant metal materials suitable for industrial environments.
- Suitable for oil & gas, petrochemical plants, refineries and industrial hazardous areas.



### 2 Technical parameters

Cable Gland Thread Type			TL-EX-ACG1 Cable				TL-EX-ACG2 Cable				
			Diameter (Ø mm) Entry		Thread Size (mm)	Size (mm)	Diameter (Ø mm) Entry		Thread Size (mm)	Size (mm)	
NPT	Gas	Metric	Entry	Outlet			Entry	Outlet			
NPT	G 1/2"	M20 x 1,5	5-12	12	15	73	5-15	5-10	15	71	
NPT	G 3/4"	M25 x 1,5	8-20	18	15	73	11-20	8-15	15	72	
NPT	G 1"	M32 x 1,5	10-25	22	17	82	14-27	11-20	17	77	
NPT	G 1 ½ "	M40 x 1,5	12-30	30	17	89	19-33	14-27	19	86	
NPT	G 1 ¼ "	M50 x 1,5	14-38	34	17	123	22-40	16-31	19	89	
NPT	G 2"	M63 x 1,5	20-48	44	17	123	29-50	29-43	19	89	
NPT	G 2 ½ "	M75 x 1,5	24-58	52	17	129	35-63	38-55	20	97	
NPT	G 3"	M88 x 1,5	30-76	65	17	143	41-77	48-65	24	106	
NPT	G 4"	M100 x 1,5	45-102	84	17	160	61-104	48-90	26	116	

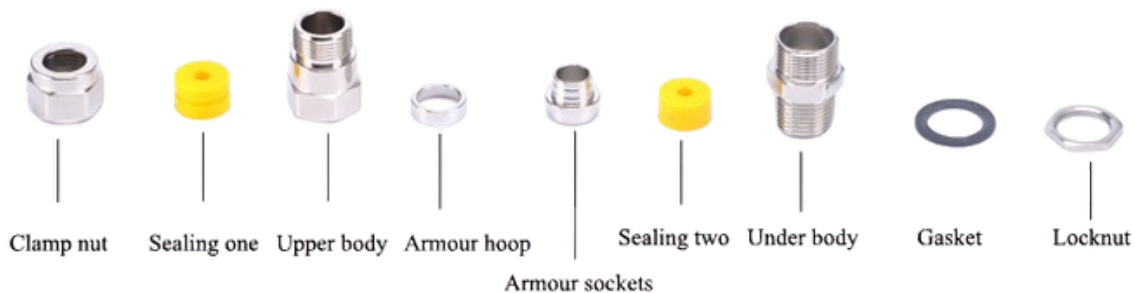

## TL-EX-ACGX Series Explosion-proof Cable Glands

Cable Type	Gland	Thread	TL-EX-ACG3 Cable			
			Diameter (Ø mm) Entry		Thread Size (mm)	Size (mm)
			Entry	Outlet		
NPT	Gas	Metric				
NPT	G 1/2"	M20 x 1,5	5-15	5-10	15	71
NPT	G 3/4"	M25 x 1,5	11-20	8-15	15	72
NPT	G 1"	M32 x 1,5	14-27	11-20	17	77
NPT	G 1 ½ "	M40 x 1,5	19-33	14-27	19	86
NPT	G 1 ¼ "	M50 x 1,5	22-40	16-31	19	89
NPT	G 2"	M63 x 1,5	29-50	29-43	19	89
NPT	G 2 ½ "	M75 x 1,5	35-63	38-55	20	97
NPT	G 3"	M88 x 1,5	41-77	48-65	24	106
NPT	G 4"	M100 x 1,5	61-104	48-90	26	116



### 3 Selection Table

Cable Type	Gland	Thread	TL-EX-ACG4 Cable				TL-EX-ACG5 Cable				
			Diameter (Ø mm) Entry		Thread Size (mm)	Size (mm)	Diameter (Ø mm) Entry		Thread Size (mm)	Size (mm)	
			Entry	Outlet			Entry	Outlet			
NPT	Gas	Metric									
NPT	G 1/2"	M20 x 1,5	9-18	9-14	15	65	7-15	5-8	15	60	
NPT	G 3/4"	M25 x 1,5	17-24	13-20	15	40	8-15	5-12	15	75	
NPT	G 1"	M32 x 1,5	23-32	18-26	15	50	11-20	8-17	15	80	
NPT	G 1 ½ "	M40 x 1,5	31-38	25-32	15	57	14-27	11-22	17	88	
NPT	G 1 ¼ "	M50 x 1,5	37-44	31-38	15	62	19-33	14-28	17	123	
NPT	G 2"	M63 x 1,5	45-55	36-47	16	70	22-40	16-33	17	123	
NPT	G 2 ½ "	M75 x 1,5	58-68	45-58	18	90	29-50	29-43	17	123	
NPT	G 3"	M88 x 1,5	67-79	56-67	20	102	35-63	38-57	17	142	
NPT	G 4"	M100 x 1,5	78-89	65-75	20	115	41-77	38-72	18	161	

## TL-EX-CGX Series Explosion-proof Cable Glands

### 1 Application and Features

- Explosion protection  
ATEX
- Application in hazardous areas  
Zone 1 & 2  
Zone 21 & 22
- Explosion protection types  
II 2G Ex db IIC Gb  
II 2D Ex tb IIIC Db
- Designed for safe cable entry into explosion-proof enclosures and equipment.\* Provides sealing, strain relief and mechanical cable retention.
- Suitable for hazardous gas and dust environments.
- Available for a wide range of cable diameters and thread sizes.
- Compatible with NPT, Gas and Metric thread systems.
- Ensures protection against dust and water ingress.
- Manufactured from corrosion-resistant materials for industrial installations.
- Designed for reliable installation in oil & gas, chemical and heavy industrial applications.



Cable Gland Thread Type			TL-EX-CG1		
NPT	Gas	Metric	Cable Diameter (Ø mm)	Thread Size (mm)	Size (mm)
NPT	G 1/2"	M20 x 1,5	6-15	15	53
NPT	G 3/4"	M25 x 1,5	6-15	15	53
NPT	G 1"	M32 x 1,5	8-18	15	57
NPT	G 1 1/2"	M40 x 1,5	12-23	15	60
NPT	G 1 1/4"	M50 x 1,5	15-30	18	60
NPT	G 2"	M63 x 1,5	20-37	18	78
NPT	G 2 1/2"	M75 x 1,5	24-46	18	82
NPT	G 3"	M88 x 1,5	50-75	20	70
NPT	G 4"	M100 x 1,5	40-90	20	78

### 2 Technical parameters

Cable Gland Thread Type	TL-EX-CG2		
	Cable Diameter (Ø mm)	Thread Size (mm)	Size (mm)
Metric			
M20 x 1,5	6-15	15	53
M25 x 1,5	6-15	15	53
M32 x 1,5	8-18	15	57
M40 x 1,5	12-23	15	60
M50 x 1,5	15-30	18	60
M63 x 1,5	20-37	18	78
M75 x 1,5	24-46	18	82
M88 x 1,5	50-75	20	70
M100 x 1,5	40-90	20	78

Cable Gland Thread Type			TL-EX-CG3		
NPT	Gas	Metric	Cable Diameter (Ø mm)	Thread Size (mm)	Size (mm)
NPT	G 1/2"	M20 x 1,5	7-15	15	68
NPT	G 3/4"	M25 x 1,5	11-20	15	68
NPT	G 1"	M32 x 1,5	14-25	17	73
NPT	G 1 1/2"	M40 x 1,5	19-33	19	80
NPT	G 1 1/4"	M50 x 1,5	24-41	19	85
NPT	G 2"	M63 x 1,5	30-50	20	93
NPT	G 2 1/2"	M75 x 1,5	38-64	21	100
NPT	G 3"	M88 x 1,5	47-54	24	103
NPT	G 4"	M100 x 1,5	62-103	26	112

## TL-EX-CGX Series Explosion-proof Cable Glands

Cable Gland Thread Type		TL-EX-CG4		
		Cable Diameter (Ø mm)	Thread Size (mm)	Size (mm)
Gas	Metric			
G 3/8	M16 x 1,5	7-15	15	53
G 1/2"	M20 x 1,5	7-15	15	53
G 3/4"	M25 x 1,5	11-20	15	57
G 1"	M32 x 1,5	14-25	17	60
G 1 ½ "	M40 x 1,5	19-33	17	60
G 1 ¼ "	M50 x 1,5	24-41	17	78
G 2"	M63 x 1,5	30-50	17	82
G 2 ½ "	M75 x 1,5	38-64	18	96
G 3"	M88 x 1,5	47-54	18	109
G 4"	M100 x 1,5	62-103	18	109



### 3 Selection Table

Cable Gland Thread Type			TL-EX-CG5		
			Cable Diameter (Ø mm)	Thread Size (mm)	Size (mm)
NPT	Gas	Metric			
NPT	G 1/2"	M20 x 1,5	6-15	15	53
NPT	G 3/4"	M25 x 1,5	8-18	15	57
NPT	G 1"	M32 x 1,5	12-23	15	60
NPT	G 1 ¼ "	M40 x 1,5	15-30	18	60
NPT	G 1 ½ "	M50 x 1,5	20-37	18	78
NPT	G 2"	M63 x 1,5	24-46	18	82



# Labeling of explosion proof equipment

According to ATEX directives

Application	Equipment Group	Equipment Categorized by		Level of Protection		Equipment Category	Explosive Atmosphere Contains	Zone Classification
Mining	I	Required Performance in the Event of an Explosive Atmosphere	Remain Functional	Very High	Two Faults	M 1	Gas Dust	
			De-energised	High	Normal Operation	M 2	Gas Dust	
Other Industries	II	Expectancy of the Occurrence of an Explosive Atmosphere	Continuously for Long Periods or Frequently	Very High	Two Faults	1	Gas Dust	Zone 0 Zone 20
			Occasionally	High	One Fault	2	Gas Dust	Zone 1 Zone 21
			Unlikely or Infrequently and for a Short Period	Normal	Normal Operation	3	Gas Dust	Zone 2 Zone 22

**Examples**

Complies with European Directive:  **0158**

Notified Body Number: **0158**

Specific Marking for Explosion Protection: 

II 2G Ex d IIC T6 Gb

II 1D Ex ta IIIA T80°C Da

Type of Environment	Group & Class	Hazardous Material in the Atmosphere						Temperature Class	
Mines	I	Firedamp	Temperatures according to coal dust accumulation on equipment (< 150°C for coal mines or < 450°C for not coal mine tunnels)						
Explosive Gases	IIA		Ammonia	Ethanol	Petrol	Diesel Fuel	Acetal-dehyde		
	IIB		Methane	Cyclohexane	Fuel Oil	n-Hexane			
	IIC		Ethane	n-Butane					
Explosive Dusts	III	A	City Gas	Ethylene	Ethyl glycol				
		B	Acrylic nitrile	Ethylene oxide	Carbon hydrogen	Ethyl ether			
		C	Hydrogen	Acetylene			Carbon disulphide		
		<b>Attention:</b> this list is only a selection of possible flammable mediums and is not complete! For dust explosion proof, the max. surface temperature is directly shown (e.g. T80°C)							
			T1 <450° C	T2 <300° C	T3 <200° C	T4 <135° C	T5 <100° C	T6 <85° C	

Protection Symbol	Zones			Type of Protection
	0	1	2	
d		*	*	Flameproof enclosure
e		*	*	Increased safety
i	ia	*	*	Intrinsic safety
	ib	*	*	
	ic	*	*	
m	ma	*	*	Moulding
	mb	*	*	
	mc	*	*	
o	*	*		Oil immersion
q	*	*		Powder filling
n	nA	*	*	Non-sparking Enclosed break Restricted Limited energy
	nC	*	*	
	nR	*	*	
	nL	*	*	
p	px	*	*	Pressurised enclosure
	py	*	*	
	pz	*	*	
Op	Op is	*	*	Optical radiation
	Op pr	*	*	
	Op sh	*	*	

Protection Symbol	Zones			Type of Protection
	20	21	22	
tD	ta	*	*	Protection by enclosure
	tb	*	*	
	tc	*	*	
mD	maD	*	*	Encapsulation
	mbD	*	*	
	mcD	*	*	
iD	iaD	*	*	Intrinsic safety
	ibD	*	*	
	icD	*	*	
pD	*	*		Pressurised enclosure

Zone Classification/Equipment Category	Equipment Protection Level (EPL)		
Zone 0/1G	Ga	Gb	Gc
Zone 1/2G			
Zone 2/3G			
Zone 20/1D	Da	Db	Dc
Zone 21/2D			
Zone 22/3D			
NA/M1	Ma		
NA/M2	Mb		

**OUR REFERENCES**

**OUR REFERENCES**

**TECHLED**

Techled Elektronik San. Tic. A.Ş.



## Contact Details:

 **Telephone:**

+90 216 386 8050

 **Fax:**

+90 216 386 8051

 **Address:**

Fatih Neighborhood, Yakacık Street,  
Türker Facilities, PK34885 No:17/3  
Samandıra - Sancaktepe/Istanbul

 **E-mail:**

info@techled.com.tr

 **Social Media:**

 techledelektronik

 techled-elektronik



Visit our  
website!

